

INDEX

1.0 GENERAL

1.1 Purpose of the Installation Guide..... 1-1

1.2 Customer’s Responsibility 1-1

2.0 SAFE ROOF INSTALLATION

2.1 Erector’s Responsibility 2-1

2.2 OSHA..... 2-1

2.3 Walking & Working on Roof Panels 2-1

2.4 Handling Roof Materials in Strong Winds 2-2

3.0 CHECKING THE STRUCTURE

3.1 Completed and Braced 3-1

3.2 Lateral Stability 3-1

3.3 Alignment 3-1

4.0 RECEIVING & HANDLING ROOF MATERIALS

4.1 Material Inventory 4-1

4.2 Equipment for Unloading and Lifting 4-1

4.3 Lifting Roof Panel Bundles 4-1

4.4 Field Storage of Roof Materials 4-2

4.5 Handling Individual Roof Panels 4-3

5.0 ROOF INSTALLATION BASICS

5.1 Proper Tools..... 5-1

5.2 Equipment List..... 5-1

5.3 Sealants..... 5-1

5.4 Fasteners..... 5-2

5.5 Field Cutting Panels and Flashing..... 5-3

6.0 ROOF PANEL LAYOUT

6.1 Sheeting Direction and Modularity..... 6-1

6.2 Layout & Checking for Coverage..... 6-1

6.3 Appearance Considerations..... 6-1

7.0 INSPECTION OF ROOF ASSEMBLY DURING INSTALLATION

7.1 Importance of Inspection 7-1

7.2 Inspection List..... 7-1

8.0 STANDARD PARTS

8.1 General..... 8-1

8.2 Panel Clips..... 8-2

8.3 Back-Up & Perimeter Plates 8-6

8.4 Closures & Gutter Support..... 8-7

8.5 Fasteners..... 8-8

8.6 Sealants & Spacer Blocks 8-10

9.0 ROOF INSTALLATION DETAILS

9.1 General..... 9-1

9.2 Preparation for Roof Panel Installation 9-2

9.3 Roof Panel Installation..... 9-8

9.4 End Dam Installation..... 9-31

9.5 Termination Panel Installation..... 9-39

9.6 Rake Trim Installation 9-49

9.7 Rake Transition Installation..... 9-55

9.8 Ridge Cover Installation..... 9-59

9.9 High Eave Transition Installation 9-65

9.10 Eave Gutter Installation 9-69

9.11 Hip and Valley Installation 9-73



1.0 GENERAL

1.1 Purpose of the Installation Guide

This installation guide is provided to SL-324 customers and their erectors as the recommended procedure for the correct assembly of the SL-324 Standing Seam Roof System.

This guide is intended to be used in conjunction with the project's erection drawings to help plan and organize the installation of the SL-324 Standing Seam Roof System. The erection drawings identify the applicable roof conditions and govern specific part arrangements. The instructions will help you identify parts, establish the installation sequence, demonstrate correct assembly, and point out any areas or procedures requiring special emphasis or attention.

This installation guide applies to the standard SL-324 Standing Seam Roof System. Custom roof conditions, including custom details and instructions, will be covered by the erection drawings. In case of conflict between this installation guide and the erection drawings, the erection drawings will have precedence.

1.2 Customer's Responsibility

The customer is responsible for proper installation of the roof in accordance with the erection drawings and this installation guide, and in accordance with good engineering and construction practices.

The customer must take the responsibility for selecting a competent erector, insist that the work be performed by qualified and experienced standing seam metal roof installers, insist that the erector take time to study and understand this guide, and assure that the erector correctly follows the guide's instructions.

The metal building supplier does not guarantee and is not liable for the quality of erection. The metal building supplier is not responsible for building defects that may be attributed to improper erection or the negligence of other parties.

Clarification concerning the SL-324 roof installation should be directed to the Customer Service Department.

2.0 SAFE ROOF INSTALLATION

2.1 Erector's Responsibility

The erector of the roof system is responsible for the safe execution of this installation guide. These instructions are intended to describe the sequence and proper placement of parts. They are not intended to prescribe comprehensive safety procedures.

If the erector cannot safely assemble the roof in accordance with these instructions, it is the responsibility of the erector to stop the work and contact the metal building supplier to determine alternate assembly procedures.

2.2 OSHA

The Occupational Safety and Health Act (OSHA) has promulgated many regulations applicable to the installation of this or any other roof system. These regulations, identified as Part 1926, Safety and Health Regulations for Construction, are available from any government bookstore. The objective of the OSHA standards is to protect the worker from injury or illness. These OSHA regulations should be recognized as job site requirements and be fully complied with.

Failure to do so may result in substantial fines in the event of an OSHA inspection. Safe installation practices may be further defined and mandated by state or local ordinances.

Maintaining good housekeeping on the jobsite is recognized as being important to both OSHA compliance and to successful job completion.

2.3 Walking & Working on Roof Panels

A. PLACING PANELS ON THE STRUCTURE

Do not place bundles of panels on the roof structure without first verifying the structure will safely support the concentrated weight of the panels and the weight of the installation crew. Some roof structures may not be designed to support the weight of a full panel bundle without additional structure support.

Do not walk on the last installed panel run, as the unsecured edge could collapse under a person's weight. When installing clips or making endlap connections, etc., stand where the roof structural will support your weight.

An approved and safe walking platform should be used in high traffic areas to prevent the roof panel from being deformed, scratched, or scuffed.

B. WALKING ON ROOF PANELS

Do not use a roof panel as a working platform. An unsecured panel could collapse under the weight of a person standing between purlins or at the panel end.

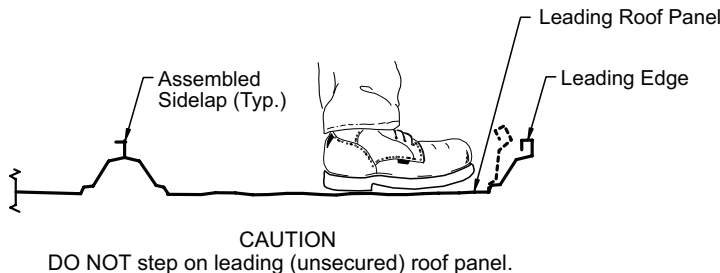
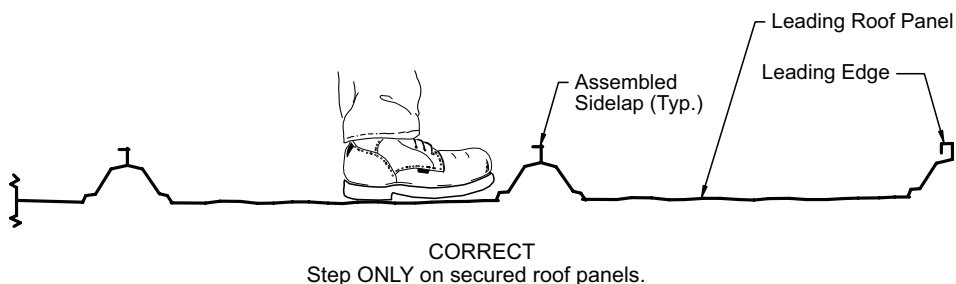

2.0 SAFE ROOF INSTALLATION

2.3 Walking & Working on Roof Panels (Continued)

C. SAFETY EQUIPMENT

The use of safety equipment for the roof panel installation is recommended at all times during the installation process. However, when using lanyards, ensure that the clasp, belt hooks and wire cables are covered in such a manner that they will not scratch the panel surface if accidentally dragged along the panel.

D. CREW SIZE

The length of the individual roof panels should be considered when determining the crew size. It is recommended that under normal conditions, there be one person for every ten feet of panel length, plus one.

E. PANEL OVERHANG

Do not stand on the end of unsupported (cantilevered) panels at the eave or ridge. Standing on the cantilever portion may result in panel collapse.

F. POINT LOADS

When properly supported by the structurals, panels are designed to support uniform loads, which are evenly distributed over the panel surfaces. Point loads that occur in small or concentrated areas, such as heavy equipment, ladders or platform feet, may cause panel deformation or even panel collapse.

G. SLICK SURFACES

Panel surfaces and structural steel surfaces are hard, smooth, and nonabsorbent, which causes these surfaces to be very slick when wet or covered with snow or ice. Even blowing sand or heavy dust can make these surfaces difficult to walk on without slipping.

Unpainted panel surfaces are often coated with oil to accommodate the panel-fabrication process. Although designed to wash away or evaporate during normal weather, the oil on new panels can be extremely slick, especially during periods of light rain or dew.

Caution must be exercised to prevent slipping and falling onto the roof surface or even sliding off the roof. Non-slip footwear is a necessity and non-slip working platforms are recommended.

H. ELECTRICAL CONDUCTANCE

Metal panels are excellent electrical conductors. A common cause of injury is the contact of metal panels with power lines during handling and installation. The location of all power lines must be noted and, if possible, flagged. The installation process must be routed to avoid accidental contact with all power lines and high voltage services and equipment. All tools and power cords must be properly insulated and grounded and the use of approved ground fault circuit breakers is recommended.

I. FALSE SECURITY OF INSULATION

Blanket and board insulation blocks the installer's view of the ground below the roof. Serious injury can occur when the installer gets a false sense of security because he cannot see the ground and steps through the insulation.

J. SHARP EDGES

Some edges of panels and flashing are razor sharp and can cause severe cuts if proper protective hand gear is not worn. Be careful not to injure others while moving panels and flashing.

2.4. Handling Roof Materials in Strong Winds

Do not attempt to move panels in strong winds. Wind pressure can easily cause a man to lose balance and fall. Strong wind uplift on a panel can lift the weight of the man carrying the panel.

Loose, wind borne panels are very dangerous and can cause severe injury and damage.

Secure stacks of panels with banding or tie-downs, so wind will not blow the panels off the roof. Clamp individual unsecured panels to the roof structurals. Clamp or block panel bundles and accessory crates to prevent them from sliding down the roof slope.

3.0 CHECKING THE STRUCTURE

3.1 Completed and Braced

Before placing materials and workers on the roof structure to start roof installation, it must be confirmed that the structure is designed to accommodate the material and erection loads as well as the appropriate live loads and wind uplift loads. It also must be determined that the structure is complete

and structurally sound with all structural connections and bracing in place and secure.

3.2 Lateral Stability

The sliding clip method of attaching the roof panels to the roof structurals provides only limited lateral stability and diaphragm bracing to the roof structurals.

Before placing materials on the roof and starting the roof installation, confirm that the necessary roof bracing and sag angles, strapping or bridging for purlin stability is in place and secured.

3.3 Alignment

Prior to installation, roof structurals should be checked for overall dimensions and evenness of plane. The roof structurals should also be checked to verify the roof system could be installed without interference. Also, roof structurals nearest the panel endlaps, ridge or high eave should be checked for correct location to properly accommodate the roof components.

To assure that the accumulation of structure length error and rake straightness error does not exceed the roof system's tolerance, the structure length should be measured from rake line to rake line at each eave, at the ridge and at each point where there is a significant error or change in rake straightness (this usually occurs at an end rafter splice).

A. TOLERANCES

To assure the roof system's correct fit-up and designed weather tightness, the structure must be aligned within the following tolerances:

Out of Square — The roof system can only accommodate 1/4" of sawtooth of the roof panel ends at the eave, ridge and panel splices. This means the allowable out of square of the rake line relative to the eave line and ridge line is 1/4" for each 40' of rake run.

Structure Width and Eave Straightness — The roof system is designed to accommodate $\pm 2"$ of overall structure width error, or $\pm 1"$ of eave straightness error at each eave.

To assure that the accumulation of the structure width error and eave straightness error does not exceed the roof system's tolerance, the structure width should be measured from eave line to eave line at each rake, at the first frame line from each rake and at each point where there is a significant error or change in eave straightness (this usually occurs at a frame line or at a wind column).

Structure Length and Rake Straightness — The roof system is designed to accommodate $\pm 2"$ of overall structure length error, or $\pm 1"$ of rake straightness error at each rake.

B. MEASURING

Structure length and width may be measured with a steel measuring tape from the face of the eave or rake member to the face of the opposite eave or rake member. The measuring tape must be parallel to the relative eave or rake line and must be stretched taut.

Eave and rake straightness may be determined by measuring deviations from a string line, which is stretched taut along the eave or rake line.

C. AESTHETIC ACCEPTANCE

Although these structure alignment tolerances will allow for reasonable roof component fit-up and ease of installation, the extremes of these tolerances may be aesthetically objectionable and should be confirmed with the customer before starting the roof installation.

D. CORRECTIONS

Any structure alignment error, which exceeds the above stated tolerances, must be corrected before roof installation can begin. If it is decided that the structure alignment errors cannot be corrected, alternate roof details may have to be developed. The alternate details may require additional materials, modified parts (with additional cost, fabrication and delivery time) and additional installation time. The metal building supplier cannot assure the performance of such alternate details.



4.0 RECEIVING & HANDLING ROOF MATERIALS

4.1 Material Inventory

Your material is carefully inspected and packaged before leaving the plant and accepted by the transportation company as being complete and in satisfactory condition. It is the carrier's responsibility to deliver the shipment intact. It is the **consignee's responsibility** to inspect the shipment for damages and shortages when it is delivered.

It is imperative that any shortages or damage of the delivered materials be noted at once and clearly marked on the bill of lading before signature of acceptance. Notify the metal building supplier immediately of any conflicts. The metal building supplier will not be responsible for shortages or damages unless they are **noted on the bill of lading**.

Conducting a material inventory at the time of delivery is essential. By conducting the materials inventory, the erector is able to identify any material shortage or damage and avoid stopping installation later because of such shortage or damage.

In the case of packaged components (such as clips, fasteners and sealants, etc.), the quantities are marked on their container and should be checked against the bill of materials. **The metal building supplier must be notified of any shortages or concealed damage within 7 days of delivery.**

4.2 Equipment For Unloading and Lifting

Hoisting equipment is necessary to unload and position the panels and accessory crates for site storage and installation. The equipment must have sufficient capacity and reach to place the material where it is required for efficient installation.

A spreader bar will be required for the longer panel bundles to assure correct sling spacing and uniform lifting. The spreader bar must be large enough to handle the maximum panel bundle weight and length.

Slings will be required to minimize panel damage. The recommended slings are nylon straps of 6" minimum width and of sufficient length to accommodate the panel bundle girth.

A forklift is handy for unloading and placing shorter panel and accessory crates.

4.3 Lifting Roof Panel Bundles

Under normal conditions, panel bundles less than 35' long can be lifted with two slings spaced at third points. Panel bundles longer than 35' can be lifted with three slings located at quarter points using a spreader bar to achieve correct sling spacing for uniform lift.

balance, and lift clearance. Tag lines should be used if necessary to control the load during lifting, especially if operating in the wind.

Slings should be located under the cross boards. Loads should always be checked for secure hook-up, proper

Panel bundles less than 25' long may be lifted with a forklift only if the forks are spread at least 5' apart and blocking is used to prevent panel damage by the forks.

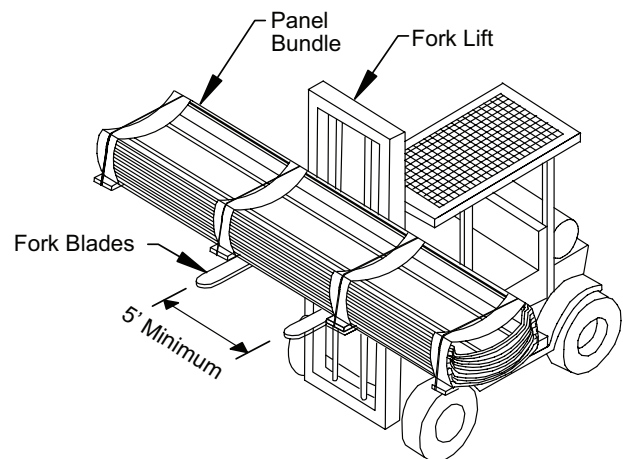
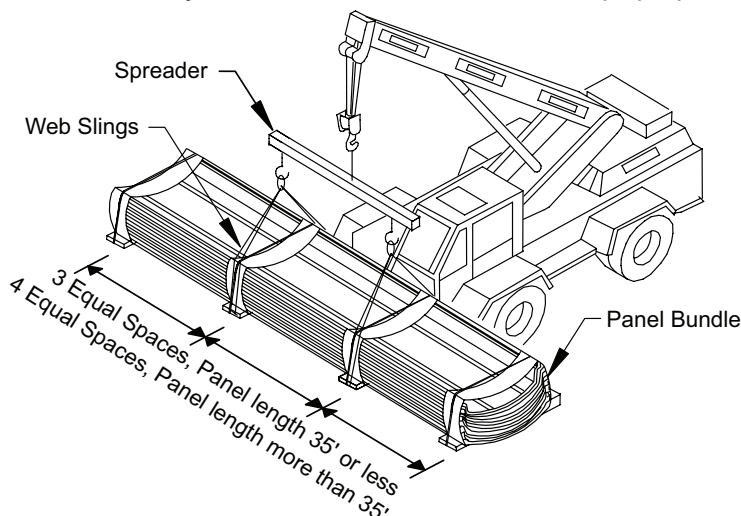

Limited to 25'

4.0 RECEIVING & HANDLING ROOF MATERIALS

4.4 Field Storage of Roof Materials

Upon acceptance of the shipment, the customer or his representative is responsible for proper handling storage and security of the roof materials. The metal building supplier is not liable for damage or loss of materials at the job site.

The roof panel bundles should be stored on the job site in accordance with the following recommendations:

- A. Store panels in a protected area, out of standing water and drifting snow, etc.
- B. Elevate panels with blocking to allow air circulation under the bundle.
- C. Slope panels for drainage of moisture from the panels.
- D. As necessary, cover panels with waterproof tarp, allowing for air circulation (do not wrap tarp under panel crate or restrict air movement).
- E. Inspect panels daily for moisture accumulation.

F. If panel bundles contain moisture, the panels should be dried and re-stacked. Use care in re-stacking to avoid damage to panels.

G. Opened or re-stacked panel bundles should be secured to prevent wind damage.

H. Store panels in a proper job site location.

When moving panel bundles, extreme caution should be taken to prevent damage to the panel edges. Loose panels should be supported at each end and at 8' spaces.

All bundles or loose panels on the roof should be banded to the roof structurals at the end of each workday. On steep roofs, provisions should be taken to prevent panels and panel bundles from sliding off the roof. Be sure to set panel bundles on the roof in the proper direction for the installation sequence.

Trim and accessories should be stored in a secure area and protected from damage, weather, and theft. Fasteners, sealants, closures, etc. should be stored out of the weather and protected from contamination.

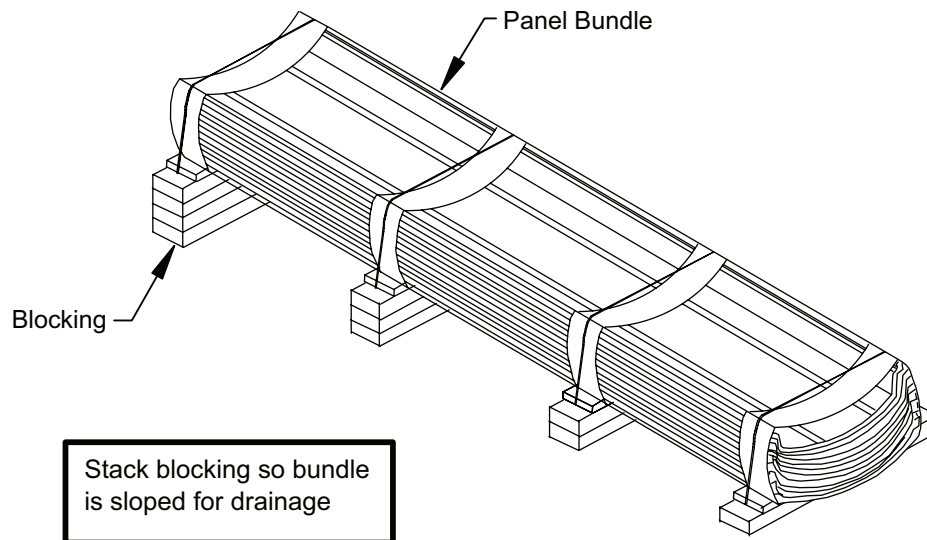

4.0 RECEIVING & HANDLING ROOF MATERIALS

4.5 Handling Individual Roof Panels

To lift individual panels, lift one side of the panel by the seam letting it hang naturally to prevent buckling. Pick-up points should not be more than 10' apart. **Do not pick-up panels by the ends only, or in a flat position.**

If the individual panels are to be lifted to the roof by hand line, the common method is to use the vice grip "C" clamps. Position the clamps on the flat of the panel, as close as possible to one edge so the panel is lifted in a vertical position.

The jaws of the vice grips must be padded to prevent damage to the panel surface. The clamps should be uniformly spaced, no more than 10' apart and the hand lines must be pulled in unison so that uneven lifting does not buckle the panel. Be sure the clamps are tight on the panel and the line is secure to prevent dropping the panel, which can result in personal injury and property damage.

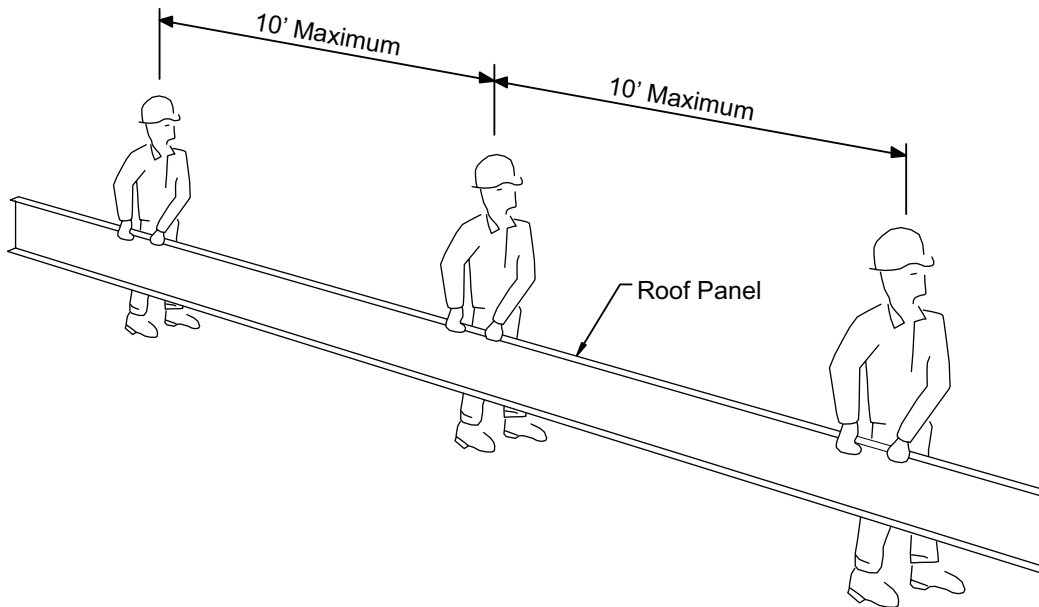

5.0 ROOF INSTALLATION BASICS

5.1 Proper Tools

Before starting paneling, be sure that the proper equipment and tools are on hand. The tools must be in good operating condition and operators should adhere to safety precautions at all times.

Improperly operating tools, too few tools, **inadequate power source**, or other equipment deficiencies slow down the installation process. The cost of inefficient working is usually greater than the cost of providing good equipment.

5.2 Equipment List

The following tools and equipment should be considered for efficient installation of the SL-324 standing seam panel. Actual tools and equipment required may vary due to variations in building type and construction.

This list should not be interpreted as a limitation to your inventory of installation equipment.

- *SL-324 Rib Clamp — Minimum of (4) required
- *SL-324 Seam Clamp — Minimum of (2) required
- *SL-324 Motorized Seaming Machine
- *ESE #812 Manual Seaming Tool
- Screw Guns — Designed for use with self-drilling screws
- Socket Extensions — 6" extension for screw gun
- Hex Socket Heads — 5/16" and 3/8", magnetic
- Drill Motor — 1/4" capacity
- Drill Bits — Assortment
- Sheet Metal Cutter — or power shears or nibbler
- "C" Clamps — vise grip type with swivel pads
- Pop Rivet Tool — 1/8" capacity
- Sheet Metal Shears — left and right cut
- Hack Saw — with metal cutting blade

- Steel Measuring Tape — 12', 50', 100'
- Nylon String Lines
- Chalk Line (NO red chalk)
- Brooms
- Marking Pen (NO lead pencils)
- Caulk Guns — for 1/10 gallon sealant tubes
- Power Source and Extension Cords — capable of handling the total equipment requirements, including 20-amp seamer machine, without power drop due to extension cord length.

*These tools are specifically designed for the SL-324 Roof Panel and are available from the metal building supplier

5.3 Sealants

A. TEMPERATURE EFFECTS

Temperature extremes must be considered during installation of the roof due to the sensitivity of sealants. The recommended installation temperature range is 20° F to 120° F. At colder temperatures, the sealant stiffens resulting in loss of adhesion and compressibility. At hotter temperatures, the sealant becomes too soft for practical handling. On cold but sunny days, the panel's surface may become warm enough to accept the application of a heated sealant even though the air temperature is below 20° F.

When overnight temperatures fall below freezing, the sealant should be stored in a heated room so it will be warm enough to use the following day. On hot days, the sealant cartons should be stored off the roof in a cool and shaded area. While on the roof, sealant rolls should be kept shaded until actual use.

In very cold weather, it is recommended that the fasteners be tightened slowly and only tight enough that the sealant is in full contact with the panel or flashing. Then on the next sunny day, complete the tightening process after the sun warms the panel and flashing surfaces.

B. CONTAMINATION

To assure proper adhesion and sealing, the sealant must have complete contact with adjoining surfaces and achieve 30% compression. Contaminants such as water, oil, dirt and dust prevent such contact. The panel and flashing surfaces must be dry and thoroughly cleaned of all contaminants. Before applying tape sealant, the sealant should be checked for contaminants. If the sealant surfaces are contaminated, it must not be used.

During cool weather, condensation or light mist can accumulate on the panel and flashing surface and not be easily noticed. It is recommended that sealants always be kept under protective cover and that the panel and flashing surfaces be wiped dry immediately before installation.

Tape sealant is provided with a protective paper to reduce contamination. Incomplete removal of the protective paper will prevent the sealant's adhesion to the panel or flashing surfaces. Always check that the protective paper is completely removed. Do not remove the protective paper until immediately before the panel or flashing is installed over the sealant.



5.0 ROOF INSTALLATION BASICS

5.3 Sealants (Continued)

C. COMPRESSION

To assure proper adhesion and seal, the tape sealant must be compressed between the panel and flashing surfaces with firm and uniform pressure. In most cases, the required pressure is applied by the clamping action of screws pulling the adjoining surfaces together. However, the tape sealant's resistance to pressure becomes greater in cold weather.

During cold weather, the fasteners must be tightened slowly to allow the sealant time to compress. If the fasteners are tightened too fast, the fastener may strip out before the sealant compresses adequately, or the panel or flash may deform in the immediate area of the fastener, leaving the rest of the sealant insufficiently compressed.

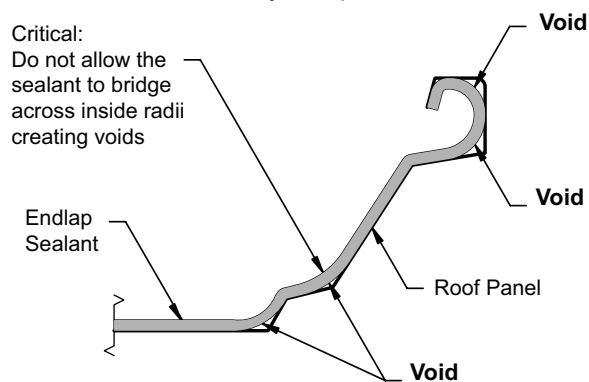

INCORRECT

D. INSIDE CORNERS

An inside radius, such as where the panel flat meets a rib, is usually the most critical area to seal. A common mistake for the installer, is to bridge the sealant across the inside radius.

When the lapping panel or flashing is pushed into place, the bridged sealant is stretched and thinned. The sealant may then be too thin to adequately seal this critical area. When tape sealant is applied at an inside radius, it is recommended that the sealant be folded back on itself, then push the sealant fold into the radius. Do not tear but cut the tape sealant to length with a box knife or equal.

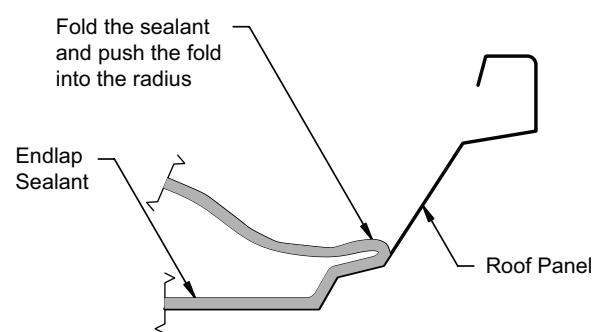

CORRECT

5.4 Fasteners

A. SCREW GUN

Use torque control and variable speed screw guns for driving self-drilling screws. 2000-2500 RPM screw gun speeds are necessary to attain efficient drilling speeds. High tool amperage (4 to 7 AMP) is required to achieve the proper torque for proper seating and to secure the fastener.

B. SOCKETS

Use good quality magnetic sockets. Good fitting sockets reduce wobble and stripping of the screw heads, especially the alloy and capped heads. They also minimize objectionable paint chipping and scuffing on colored screws and minimize damage to the protective coating on unpainted screws.

Magnetic sockets collect drill shavings, which will build up and eventually prevent the socket from seating properly on the screw heads. One method of removing the drill shavings is to roll up a ball of tape sealant and push the socket into the sealant.

When the socket is removed from the sealant, most of the drill shavings will remain embedded in the sealant thereby

cleaning the socket. This process should be repeated as often as needed to keep the socket clear of drill shavings.

C. SOCKET EXTENSION

A 4" or 6" socket extension is recommended for installing the panel clip screws. With the extension the screw can be driven straight down without tilting the screw gun to clear the panel or clip. Since socket extensions are slow to wear out, it is usually more cost effective to purchase socket extensions and good quality sockets rather than purchase sockets with built-in extensions.

D. INSTALLATION

Before starting the screw, the materials to be joined must be pressed together with foot or hand pressure. The pressure must be maintained until the screw has drilled through all the materials and the threads have engaged.

Most self-drilling screws require 20 pounds of pressure to maintain the drilling action and to start the thread cutting action. Also, applying such pressure before starting the screw gun will usually prevent tip walking or wandering.

5.0 ROOF INSTALLATION BASICS

5.4 Fasteners (Continued)

D. INSTALLATION (continued)

If too little pressure is applied, the drill point may not cut into the metal and the point will heat up and become dull. If the pressure is too heavy, the bottom material may be deflected away, causing a standoff condition, or the drill tip may be broken or splits. Screws must be held perpendicular to the panel or flashing surface during starting and driving.

For proper seating of the fastener-sealing washer, the panel or flashing surface must be clean and drill shavings must be removed from under washers before seating. The fastener must be driven perpendicular to the panel surface so that the washer can seat level without warping or cupping.

Do not over drive screws. Over driving can strip the threads and/or damage the sealing washer. Use screw gun with torque control set to function properly for the combination of fastener size, hole size and material thickness.

The fastener should be driven tight enough to uniformly compress the washer but not so tight that the washer splits

or rolls out from under it's metal dome. The recommended procedure is to tighten the fastener until the sealing washer just starts to visually bulge from under the metal dome.

As a good installation practice, all roof installers should carry approved oversized screws. Upon stripping or breaking a screw, the screw must be immediately removed and replaced with the appropriate oversized screw. Do not defer the screw replacement to be remembered and fixed later, or to be found by the clean-up crew. The majority of such screws will be overlooked until the customer complains of leakage.

NOTE: Panel clip fastener torque should be tested prior to installation of any panel clips. Install a clip to a scrap piece of sheeting angle. Make adjustments so the torque setting will allow the clip base to properly close and rest on the base's internal supports, but not restrict the tab's movement through the base.

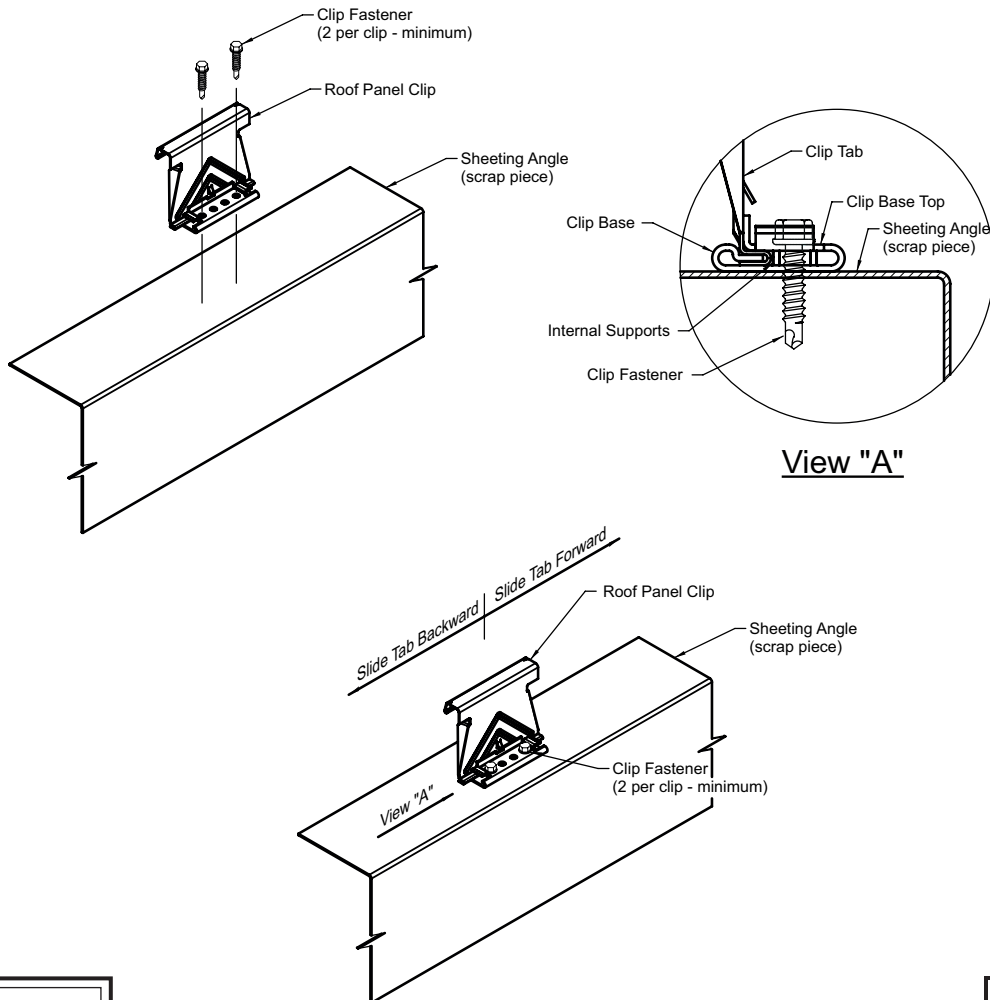

5.0 ROOF INSTALLATION BASICS

5.5 Field Cutting Panels and Flashing

A. ABRASIVE SAW PROBLEMS

Abrasive saws (circular saws with friction disks) are not recommended for cutting roof panels or flashing. Abrasive saws create high heat that may burn away the protective coating from the panel edge, causing the edge to rust.

Also, abrasive saw dust contains fine, hot steel particles, which accumulate on panel and flashing surfaces where they rust and can cause staining and rusting of those surfaces.

Rust caused by abrasive saw damage or abrasive dust particles can be excluded from warranty claims.

B. SHEARING METHODS

It is recommended that panels and flashing be cut with shears to provide a clean, undamaged cut. On shear cut edges, the protective coating extends to the edge of the cut and is often wiped over the edge to further protect the base metal. Whenever possible, fit the material so that the factory cut edge is exposed and the field cut edge is covered.

When field cutting complex shapes, it is usually easier to cut out a 1" wide strip using both left and right hand shears. The 1" cutout provides clearance to smoothly cut the flats and the clearance to work the shears around tight corners.

When making repetitive cuts (such as cutting panels at a hip condition) it is recommended that a template be made from a piece of drop-off panel or flash to provide fast and accurate marking of the field cut. When using panel material for the template, cut off the top portion of the panel ribs so that the template is easily laid onto the panel being marked.

C. MARKING PANELS

Avoid marking the panels for cutting, etc., in a manner that will leave visible markings stains, etc., on the finished roof surface. Use chalk or felt tip ink markers. **Do not use graphite (lead) pencils on unpainted panel surfaces.** The graphite can cause rusting of the surface.

6.0 ROOF PANEL LAYOUT

6.1 Sheeting Direction and Modularity

Although the SL-324 roof system is designed so it can be installed in either direction (left to right or right to left), there may be roof conditions which require a specific sheeting direction. Check the erection drawings to determine if a specific sheeting direction is required.

The recommended installation sequence is to complete each panel run from eave to ridge before starting the next panel run. This sequence will help ensure straight runs and allow the insulation to be installed immediately ahead of each panel run.

During installation of the roof, considerations must be made for maintaining panel modularity. By maintaining panel modularity, the roof panel sidelap and seam can be properly assembled, the proper roof coverage can be obtained, and the standard perimeter parts will fit properly without necessity of field modifications or reordering of parts, etc.

Caution: **Failure to maintain panel coverage** width within the specified tolerance can cause faulty roof panel seams which can result in seaming difficulty or in severe cases reduction in roof performance specifications.

The panels must be held to the width dimension of the panel as designated on the erection drawings within a 1/8" width tolerance per panel. The accumulated coverage (start panel to finish panel) tolerance is determined by the ability to keep the panels parallel and to correctly fit and assemble the finish rake condition.

If the roof has conditions such as fixed location penetrations, parapets, fire walls, etc., the accumulated panel coverage may require tighter tolerances for proper fit-up and weather tightness of the roof system.

6.2 Layout & Checking for Coverage

Recommended for all roofs, but a must for large or complex roofs, is to make a layout of the actual structure (field measured as described in section 3.3) so that the roof panel start and stop dimensions can be laid out to accommodate any structural misalignments.

When the optimal start and finish dimensions are determined, a string line should be set to precisely locate the leading edge of the start panel. After the start panel is secured and engaged with the next panel, the start panel seam will be the reference line for checking accumulated panel coverage.

Panel coverage is always checked at the eave, ridge, and end splices so that non-parallel seam (or dogleg) conditions can be detected and corrected before they become objectionable. The coverage check should be done with a measuring tape held taut and measured to the same side of the seam and always parallel to the eave to prevent any measuring error.

Every four to six panel runs should be checked for panel modularity. This will assure that the panels are maintaining a straight line and proper coverage is being maintained. If the panels are off module, they should be corrected by equal adjustments of the next four to six panel runs.

6.3 Appearance Considerations

Although the above stated coverage tolerance will provide for reasonable ease of installation and water tightness, such visible conditions as non-parallel panel seams, dogleg of the panel seam at the end splices, non-parallel finish panel

width, and mismatch of panel seams across the ridge, may be objectionable and should be confirmed with the customer before continuing roof installation.



7.0 INSPECTION OF ROOF ASSEMBLY DURING INSTALLATION

7.1 Importance of Inspection

During the roof installation, all areas of the roof system assembly must be frequently inspected to ensure the correct assembly in accordance with the erection drawings and this installation guide.

Failure to assemble the roof system correctly will result in roof performance problems that may require costly corrective work, roof replacement and performance and damage claims etc. Also, incorrect installation may void the performance and material warranties.

7.2 Inspection List

A. ERECTION DRAWINGS

Check that the erection drawings are available at the job site and have been reviewed for difference with the actual job conditions and differences with this installation guide. Also, confirm that the drawings are the latest issue with the latest revisions and additions.

B. ROOF LAYOUTS

Check that the roof start and finish dimensions have been correctly determined based on the erection drawings and the actual structural conditions.

C. BEFORE INSTALLING ROOF PANELS

Check that the structural misalignments were corrected in accordance with Section 3.0 of this installation guide.

Check that the correct eave and rake plates and eave trim are in place before installing the roof panels.

Check that the roof panel elevation provided by the panel clip height and insulation system matches the eave and rake plate elevation.

D. PANEL LENGTH

Check that the installed roof panels have the correct overhang at the eave and endlaps and have the correct hold back at the ridge or high eave, in accordance with the erection drawing.

E. EAVE SEAL

Check that the eave sealant is in the correct position on top of the eave trim and that the corrugation closure and eave pigtail sealant are correctly placed. Check that the

eave fasteners penetrate the center of the eave sealant and into the eave plate. Check that the fasteners are not loose or stripped.

Check that the eave sealant is in complete contact with the roof panel and eave trim without any voids or gaps. Confirm that the roof panel and eave trim are clean and dry during installation and that the sealant is not wet or otherwise contaminated.

F. ENDLAP SEAL

Check that the roof panel endlaps are correctly assembled and that the lapping panels are tightly nested without visible gaps.

Check that the sealant is in the correct position and is in complete contact with the lapped panels without any voids or gaps, especially at the radius between the panel flat and the vertical legs of the panel. Confirm that the panels are clean and dry during installation and that the sealant is not wet or otherwise contaminated.

Check that the pigtail sealant is in the correct position and seals the endlap seam notches.

Check that the cinch strap fasteners penetrate through the center of the sealant and into the back-up channel. Check that the fasteners are not loose or stripped.

Check that the endlap assembly is not bowed down causing water ponding and debris accumulations.

7.0 INSPECTION OF ROOF ASSEMBLY DURING INSTALLATION

7.2 Inspection List (Continued)

G. RIDGE SEAL

Check that the ridge closure assembly is correctly assembled.

Check that the sealant is in the correct position and is in complete contact with the closure and the roof panel without any voids or gaps. Confirm that the closures and roof panels are clean and dry during installation and the sealant is not wet or contaminated.

Check that the closure fasteners penetrate through the center of the sealant and into the back-up plate. Check that the fasteners are not loose or stripped.

Check that the tube sealant is installed along the back of the closure as necessary to seal any voids around the panel seam area.

H. RAKE SEAL

Check that the termination zee is correctly assembled with the termination zee splices correctly oriented for downhill watershed.

If there are roof panel endlaps, check that the endlap sealant contacts the termination zee sealant or that a pigtail sealant is applied for that purpose.

Check that the sealant is in the correct position above and below the roof panel.

Check that the termination zee sets fully on the sealant and that the sealant is in complete contact with the roof panel and the zee without any voids or gaps. Confirm that the roof panel and zee are clean and dry during installation and that the sealant was not wet or contaminated.

Check that the termination zee fasteners penetrate the center of the sealant and into the rake plate. Check that the fasteners are not loose or stripped.

I. PANEL CLIP ATTACHMENT

Check that the panel clips are correctly fitted to the panel without any distortion or damage of the clip tab. On sliding clips, check that the clip tab is centered on the clip base between the centering tabs.

Check that the clips are located along each panel sidelap at each roof structural or at the locations specified on the erection drawings.

Check that the panel clip fasteners are of the type, size, length, finish and quantity-per-clip as specified on the erection drawings.

Check that the panel clip fasteners are not loose or stripped. In the case of multi-layered construction, verify that the fasteners penetrated and engaged the specified structural member.

J. SIDELAP

Check that the panel sidelaps are on module (held to within the 1/8" panel width tolerance) and are assembled so that the male and female panel edges and panel clips are properly nested together prior to seaming.

Check that the full length of each sidelap seam is correctly seamed.

Check that the factory installed sidelap sealant is in the correct position without voids or interruptions and is not damaged, wet or otherwise contaminated.

Check that the panel coverage tolerance does not exceed 1/8" per panel and that the accumulated coverage will allow proper fit and assembly of the end dams and finish rake condition and any other critical fit conditions such as penetrations, parapets, etc.

K. FLASHING AND PENETRATIONS

Check that all flashing (including penetrations) are correctly assembled and tightly fitted. Check that the required sealants are correctly positioned and in complete contact with the adjoining surfaces without voids or interruptions. Confirm that the sealants and adjoining surfaces are clean and dry during installation.

Check that the flashing splices are correctly lapped, sealed and fastened.

Check that the flashing is sufficiently pitched to shed water and eliminate ponding areas, especially at the critical splices, endlaps and corners.



7.0 INSPECTION OF ROOF ASSEMBLY DURING INSTALLATION

7.2 Inspection List (Continued)

Check that the fasteners are of the specified type, size, length, finish and spacing. Check that the fasteners are not loose or stripped. Check that the sealing washers are in full contact with the flashing surface and not distorted, split or otherwise damaged.

Along the rakes, high eave transitions and fixed penetrations, check that the flashing is not constrained and will allow for the roof's expansion/contraction movement.

L. SURFACE CONDITIONS

Damaged roof system surfaces are subject to corrosion and performance problems and may void the material and performance warranties.

Check that the panel and flashing surfaces are not being subjected to abusive conditions such as: careless handling of panels and flashing, excessive roof traffic, abrasive or contaminated footwear, rough handling of materials, tools and equipment, or contact with abrasive materials or residue.

Check that the panel and flashing surfaces are not being subjected to exposed metal objects and materials left on the roof such as: tools, material drop-off, fasteners, wire, staples, drill and nibbler chips, saw and file particles. In the process of rusting, these materials will absorb the panel's protective coating, thus leaving the panels exposed to rusting.

Check that the panels and flashing are not being subjected to long term wet conditions such as: standing water, consistent sources of steam, mist, spray, dripping or runoff, wet debris, wet insulation or other moisture holding material.

Check that the panels and flashing are not subjected to direct contact or runoff from corrosive materials such as: copper pipes and flashing, uncured cement, treated lumber anti-icing chemicals, strong solvents or other corrosive materials.

Check that graphite pencils were not used to mark on unpainted surfaces. The **graphite marks can cause rusting**.

Check that the roof materials are not subjected to damaging heat such as: cutting torches, abrasive saws, etc.

M. UNSPECIFIED MATERIALS

Use of the wrong materials may cause installation and performance problems and may void the performance and material warranties.

Check that all installed roof system materials, especially sealants and fasteners, are only those which are provided or specified by the metal building supplier for your specific project and are used only as specified on the erection drawings and this installation guide.

The metal building supplier cannot be responsible for the performance of roof materials that are not provided, specified or approved by the metal building supplier.

8.0 STANDARD PARTS

8.1 General

The following details provide a basic description and graphic illustrations of the standard roof assembly parts. The purpose of these details is to assist the erector in the correct selection and identification of parts.

Because of the many variations in conditions, it is important that you review the job conditions to identify the specific parts required for your job.

Review the erection drawings for any special parts or parts which are different from the standard parts shown in these details. If differences exist, the erection drawings will have preference.

For proper fit-up, sealing and fastening, and to help ensure the roof assembly's weathertightness, structural capability, durability and appearance, the correct parts must be used. Do not use parts other than those specified on the erection drawings.

ROOF PANEL (24" wide panel)

- 24 or 22 gauge Steel
- Painted or Galvalume Finish
- Striated Pan
- Factory notched for endlap
- Factory punched holes

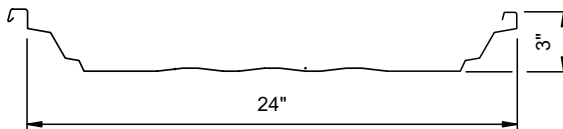
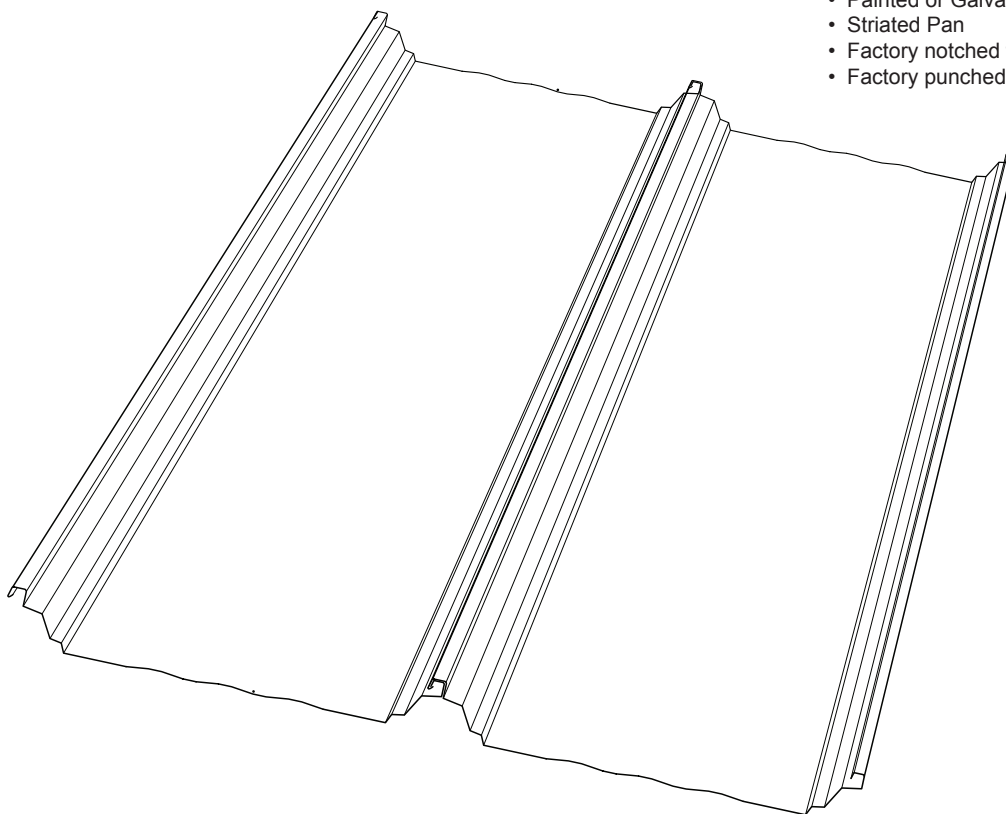

Part No. TS324
(Specify gauge, finish & length)

8.0 STANDARD PARTS

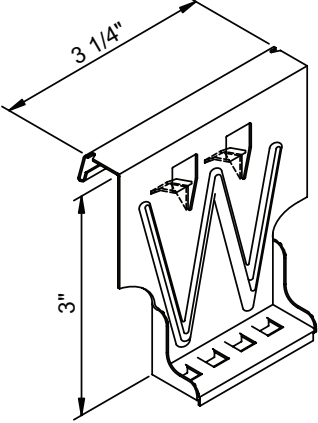
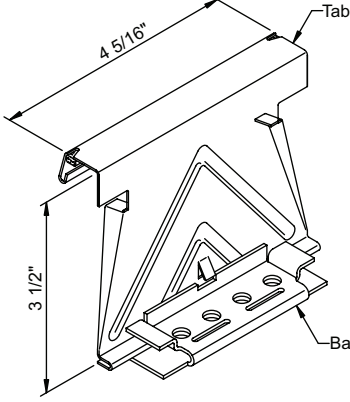
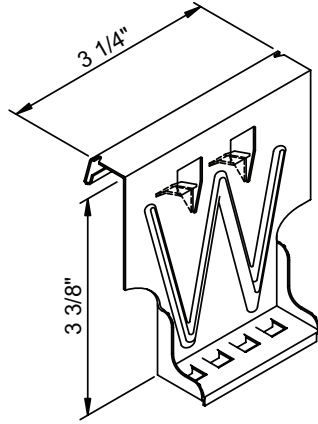
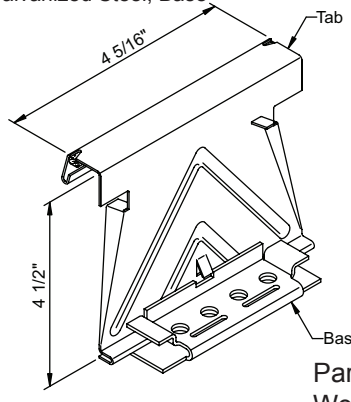
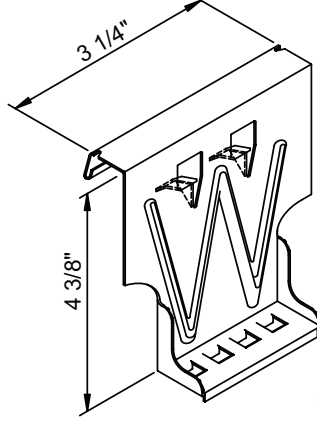
<p>FIXED CLIP (for 0" stand-off) • 20 ga. Galvanized Steel</p>  <p>FM Approved UL listed</p> <p>Part No. FC461 Weight - 0.18</p>	<p>PURLIN STABILIZING FLOATING CLIP (for 1/2" stand-off) • 20 ga. Galvanized Steel, Tab • 16 ga. Galvanized Steel, Base</p>  <p>FM Approved UL listed</p> <p>Part No. MPS602 Weight - 0.40</p>
<p>FIXED CLIP (for 1/2" stand-off) • 20 ga. Galvanized Steel</p>  <p>FM Approved UL listed</p> <p>Part No. FC462 Weight - 0.20</p>	<p>PURLIN STABILIZING FLOATING CLIP (for 1-1/2" stand-off) • 20 ga. Galvanized Steel, Tab • 16 ga. Galvanized Steel, Base</p>  <p>FM Approved UL listed</p> <p>Part No. MPS603 Weight - 0.45</p>
<p>FIXED CLIP (for 1-1/2" stand-off) • 20 ga. Galvanized Steel</p>  <p>FM Approved UL listed</p> <p>Part No. FC463 Weight - 0.25</p>	

8.0 STANDARD PARTS

Floating Clip (for 1/2" stand-off)

- 20 ga. Galvanized Steel, Tab
- 16 ga. Galvanized Steel, Base
- Do not use on FM Roofs
- UL Listed

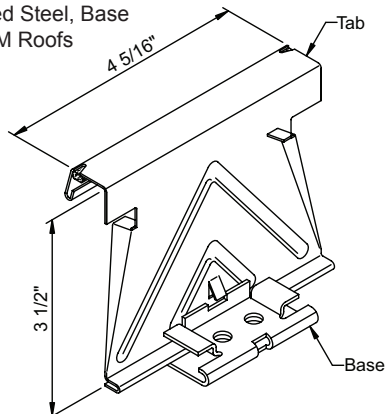

Part No. MPS602-3
Weight - 0.35

Floating Clip (for 1-1/2" stand-off)

- 20 ga. Galvanized Steel, Tab
- 16 ga. Galvanized Steel, Base
- Do not use on FM Roofs
- UL Listed

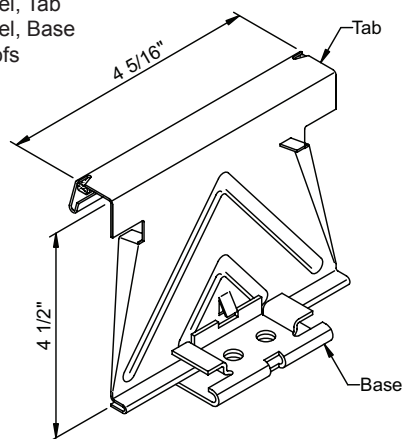

Part No. MPS603-3
Weight - 0.39

PURLIN STABILIZING FLOATING CLIP (for 2" stand off)

- 20 ga Galvanized Steel, Tab
- 16 ga. Galvanized Steel, Base
- UL Listed

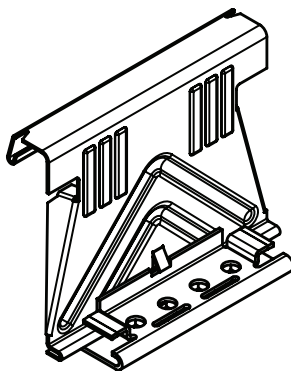

Part No. MPS 607
Weight - 0.46

PURLIN STABILIZING FLOATING CLIP (for 2-1/2" stand off)

- 20 ga Galvanized Steel, Tab
- 16 ga. Galvanized Steel, Base
- UL Listed

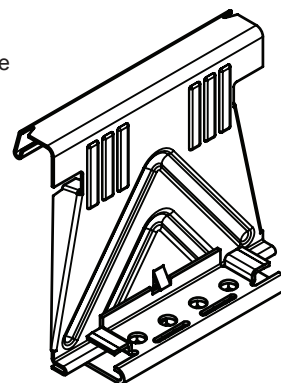

Part No. MPS 608
Weight - 0.47

PURLIN STABILIZING FLOATING CLIP (for 3" stand off)

- 20 ga Galvanized Steel, Tab
- 16 ga. Galvanized Steel, Base
- UL Listed

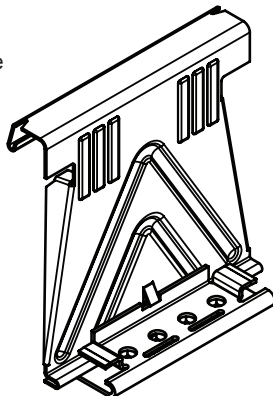

Part No. MPS 609
Weight - 0.48

8.0 STANDARD PARTS

SEALANTLESS PURLIN STABILIZING FLOATING CLIP (for 1/2" stand-off)

- 20 ga. Galvanized Steel, Tab
- 16 ga. Galvanized Steel, Base
- Do **NOT** use on FM roofs
- UL Listed

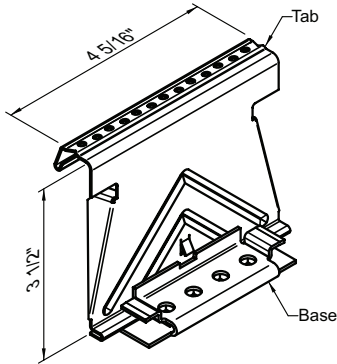

Part No. MPS 604
Weight - 0.40

SEALANTLESS PURLIN STABILIZING FLOATING CLIP (for 1/2" stand-off)

- 20 ga. Galvanized Steel, Tab
- 16 ga. Galvanized Steel, Base
- Do **NOT** use on FM roofs
- UL Listed

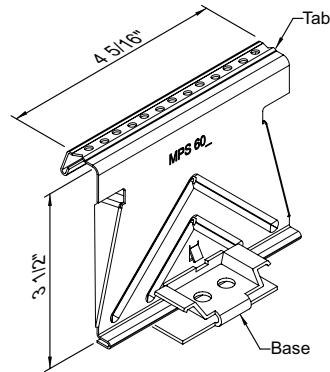

Part No. MPS 604-3
Weight - 0.35

SEALANTLESS PURLIN CLIP (for 1 1/2" stand-off)

- 20 ga. Galvanized Steel, Tab
- 16 ga. Galvanized Steel, Base
- Do **NOT** use on FM roofs
- UL Listed

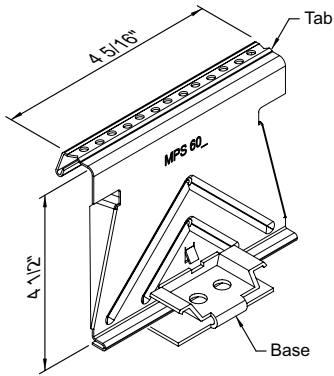

Part No. MPS 605-3
Weight - 0.39

SEALANTLESS PURLIN CLIP (for 1/2" stand-off)

- 20 ga. Galvanized Steel, Tab
- 16 ga. Galvanized Steel, Base
- Do **NOT** use on FM roofs
- UL Listed

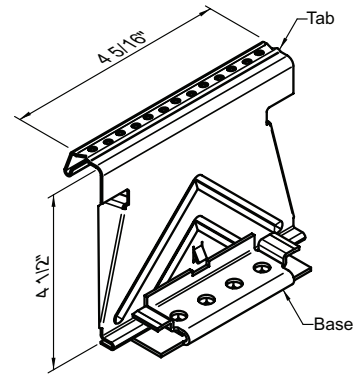

Part No. MPS 605
Weight - 0.45

HIGH WIND PURLIN CLIP (for 1/2" stand-off)

- 20 ga. Galvanized Steel, Tab
- 16 ga. Galvanized Steel, Base
- Do Not Use on FM Roofs
- UL Listed

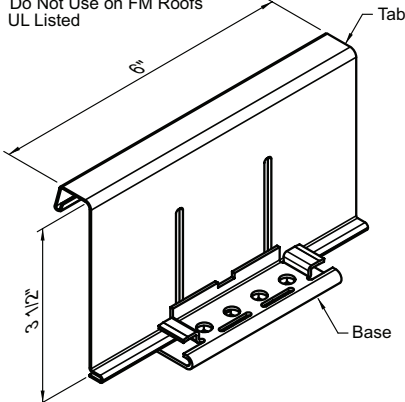

Part No. BA 602-6
Weight - 0.48

HIGH WIND PURLIN CLIP (for 1/2" stand-off)

- 20 ga. Galvanized Steel, Tab
- 16 ga. Galvanized Steel, Base
- FM Approved
- UL Listed

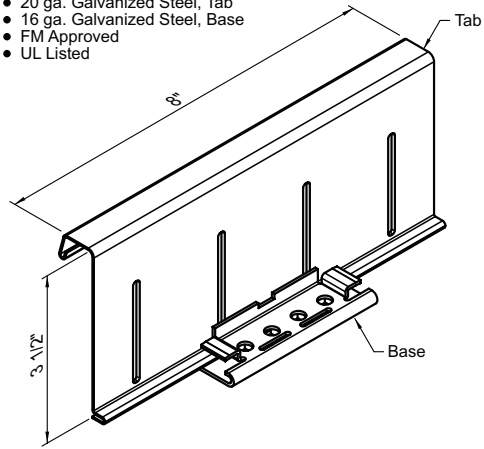

Part No. BA 602-8
Weight - 0.58

8.0 STANDARD PARTS

- HIGH WIND PURLIN CLIP (for 1/2" stand-off)
- 20 ga. Galvanized Steel, Tab
 - 16 ga. Galvanized Steel, Base
 - Do Not Use on FM Roofs
 - UL Listed

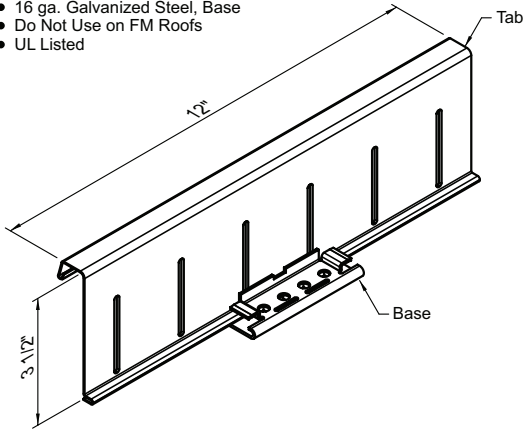

Part No. BA 602-12
Weight - 0.80

- HIGH WIND PURLIN CLIP (for 1/2" stand-off)
- 20 ga. Galvanized Steel, Tab
 - 16 ga. Galvanized Steel, Base
 - Do Not Use on FM Roofs
 - UL Listed

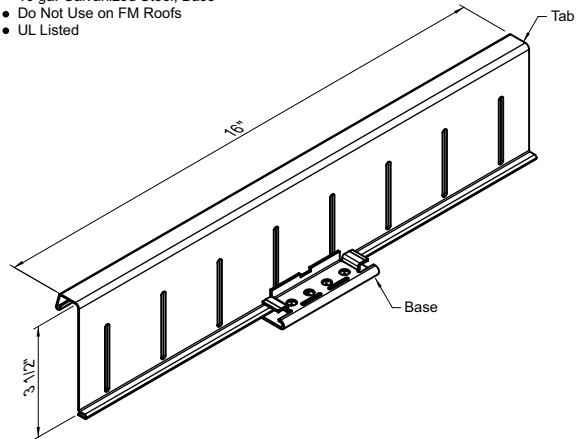

Part No. BA 602-16
Weight - 1.00

- HIGH WIND PURLIN CLIP (for 1 1/2" stand-off)
- 20 ga. Galvanized Steel, Tab
 - 16 ga. Galvanized Steel, Base
 - Do Not Use on FM Roofs
 - UL Listed

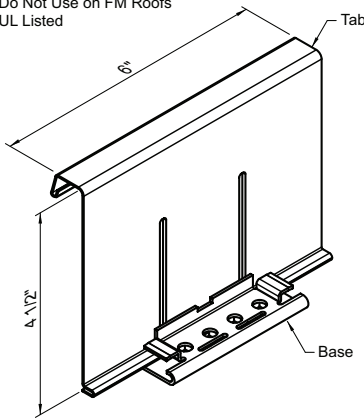

Part No. BA 603-6
Weight - 0.50

- HIGH WIND PURLIN CLIP (for 1 1/2" stand-off)
- 20 ga. Galvanized Steel, Tab
 - 16 ga. Galvanized Steel, Base
 - FM Approved
 - UL Listed

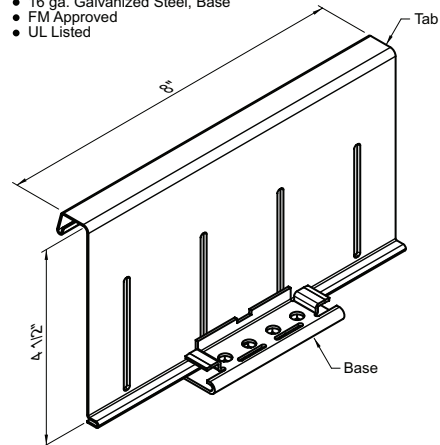

Part No. BA 603-8
Weight - 0.60

- HIGH WIND PURLIN CLIP (for 1 1/2" stand-off)
- 20 ga. Galvanized Steel, Tab
 - 16 ga. Galvanized Steel, Base
 - Do Not Use on FM Roofs
 - UL Listed

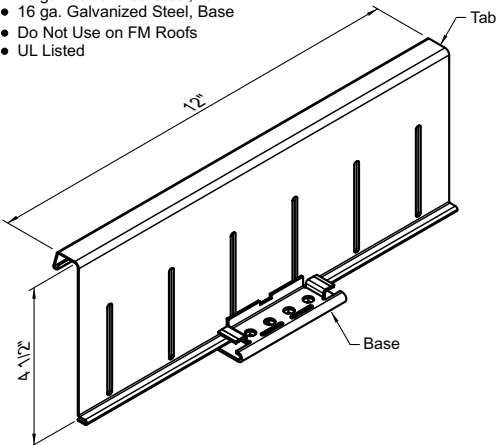

Part No. BA 603-12
Weight - 0.90

- HIGH WIND PURLIN CLIP (for 1 1/2" stand-off)
- 20 ga. Galvanized Steel, Tab
 - 16 ga. Galvanized Steel, Base
 - Do Not Use on FM Roofs
 - UL Listed

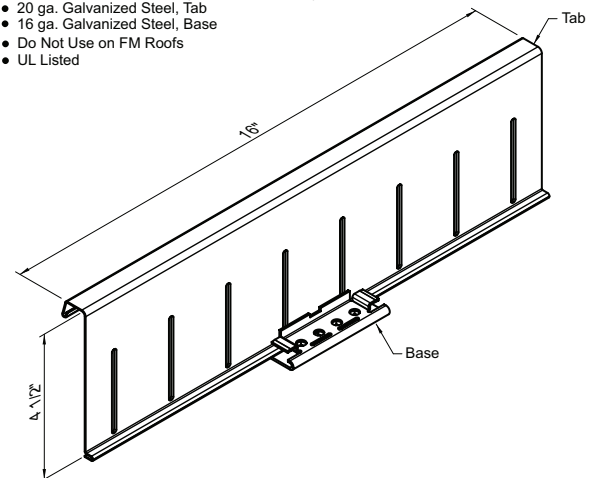

Part No. BA 603-16
Weight - 1.20

8.0 STANDARD PARTS

ENDLAP BACK-UP PLATE (for 24" panel)

- 16 gauge Galvalume Steel
- Factory punched holes

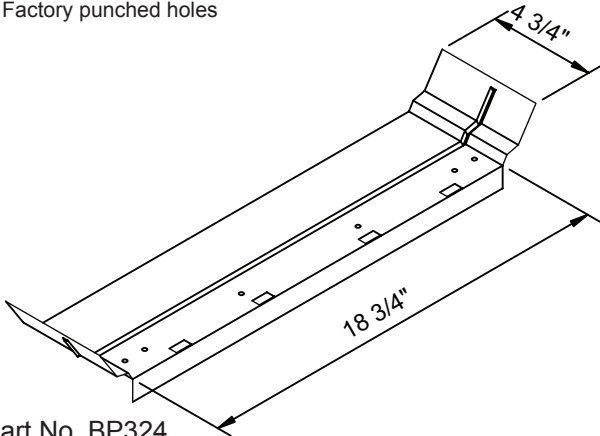

Part No. BP324
Weight - 2.40

ENDLAP BACK-UP PLATE-2nd GEN (for 24" panel)

- 16 ga. Galvalume Steel
- Factory punched holes
- All stand-offs greater than 0" Stand-off

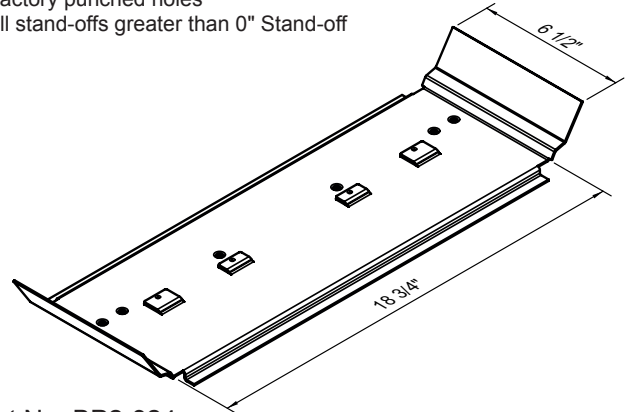

Part No. BP2-324
Weight - 3.06

ENDLAP BACK-UP PLATE-2nd GEN. (for 24" panel)

- 16 ga. Galvalume Steel
- Factory punched holes
- ZERO (0") STAND-OFF

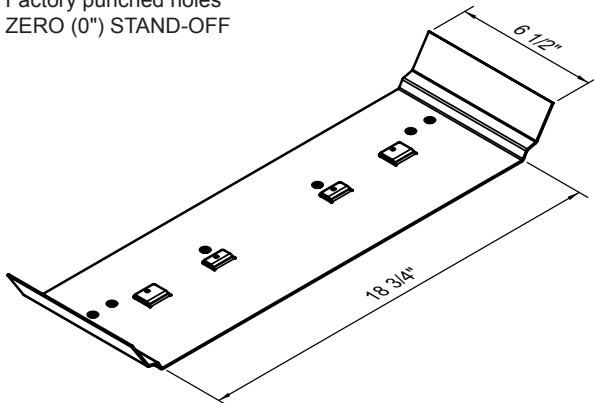

Part No. BP2-324-0
Weight - 2.65

PERIMETER PLATE (for 3/8" stand-off)

- 16 gauge, 50 ksi Galvanized Steel
- 10'-0" length
- Factory punched slots

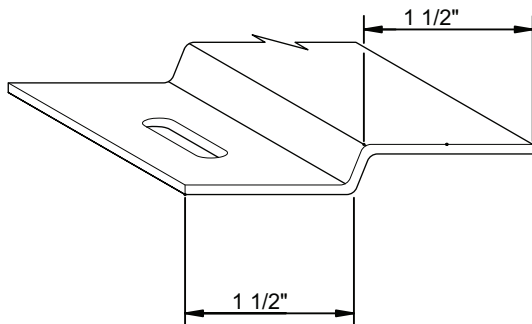

Part No. RP038
Weight - 8.47

PERIMETER PLATE (for 1 3/8" stand-off)

- 16 gauge, 50 ksi Galvanized Steel Min.
- 10'-0" length
- Factory punched slots

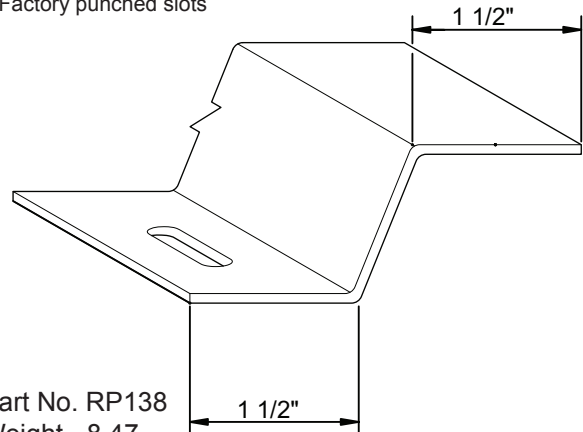

Part No. RP138
Weight - 8.47

8.0 STANDARD PARTS

CORRUGATION CLOSURE

- 18 gauge Steel (Part No. CC324-18)
- 22 gauge Steel (Part No. CC324)
- Painted or Galvalume Finish
- Factory punched hole

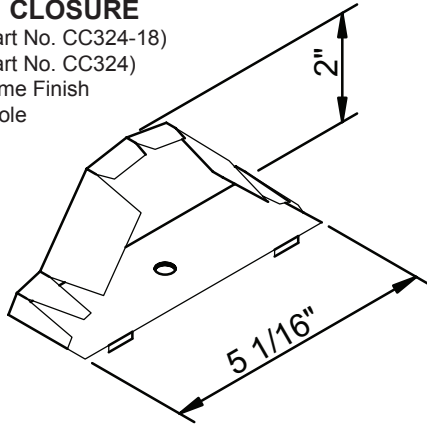

Part No. CC324-18 (specify finish)
 Part No. CC324 (Specify finish)
 Weight - 0.24

TERMINATION ZEE

- 24 or 22 gauge Steel
- Painted or Galvalume finish
- 10'-2" length

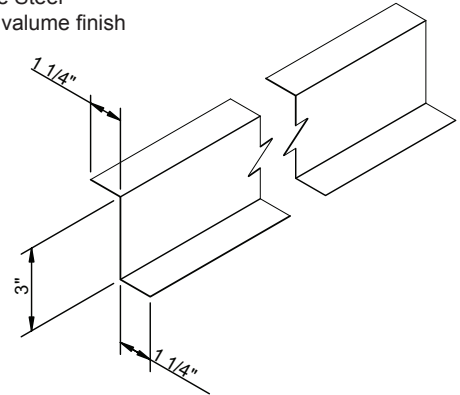

Part No. TZ310 (Specify gauge & length)
 Weight - 4.54 (24 gauge)
 Weight - 5.68 (22 gauge)

END DAM (for 24" wide panel)

- 24 gauge Steel
- Painted or Galvalume Finish
- Factory punched holes

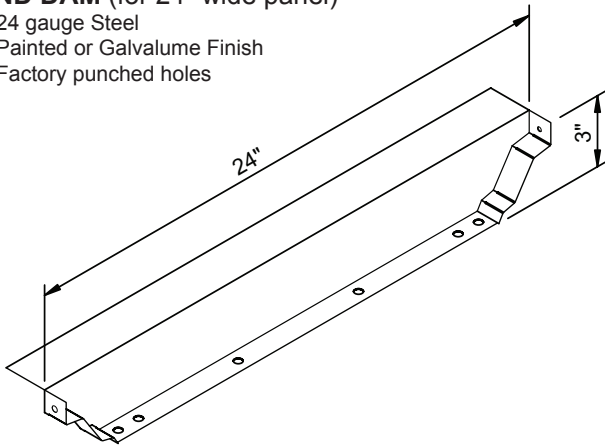

Part No. ED324 (Specify finish)
 Weight - 1.09

ENDLAP CINCH STRAP (for 24" wide panel)

- 18 gauge Stainless Steel
- Factory punched holes

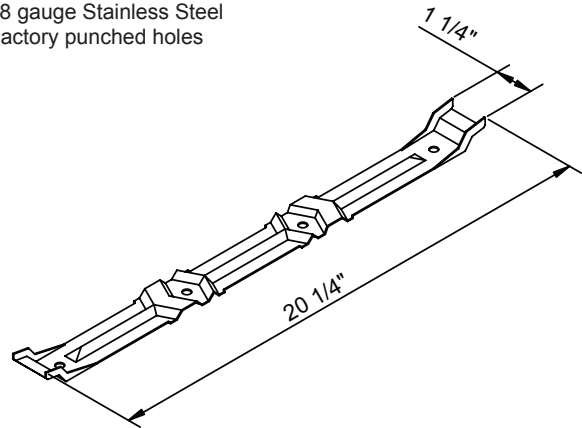

Part No. CS324
 Weight - 0.34

SOUTHERN STYLE GUTTER SUPPORT

- G-90 galvanized 50 ksi
- 0.052 thick 18 ga.

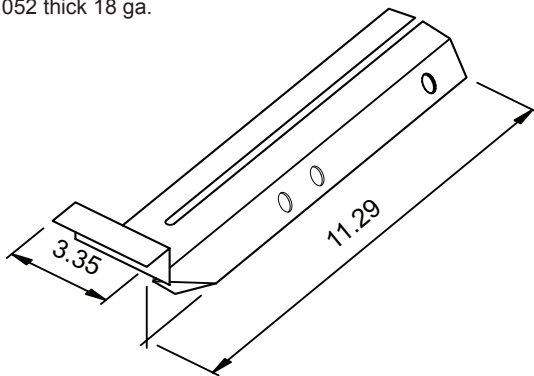

Part No. CC 601
 Weight - 0.74

NORTHERN STYLE GUTTER SUPPORT

- G-90 galvanized 50 ksi
- 0.052 thick 18 ga.

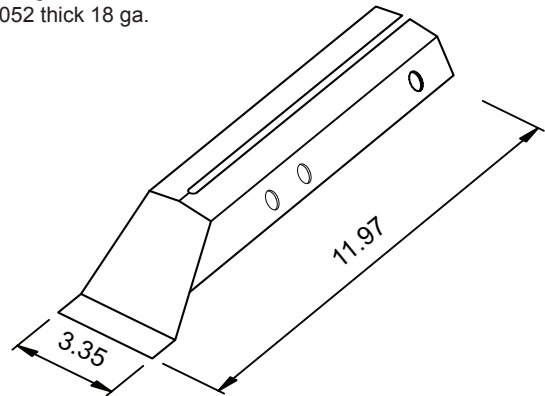

Part No. CC 602
 Weight - 0.71

8.0 STANDARD PARTS

ENDLAP FASTENER

(for panel endlap attachment)

- #17 - 14 x 1" Self Tapping Screw
- EPDM Sealing Washer
- Corrosion resistant coating or alloy head
- Painted or mill finished head

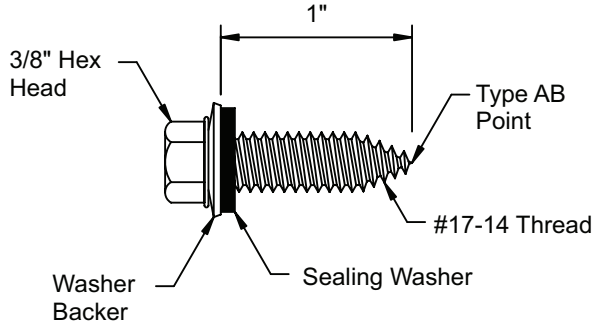

Part No. RF1 (Specify finish)

ROOF FASTENER

(for panel edge attachment)

- #12 - 14 x 1 1/4" hex head, Self Drilling Screw
- EPDM Sealing Washer
- Corrosion resistant coating or alloy head
- Painted or mill finished head

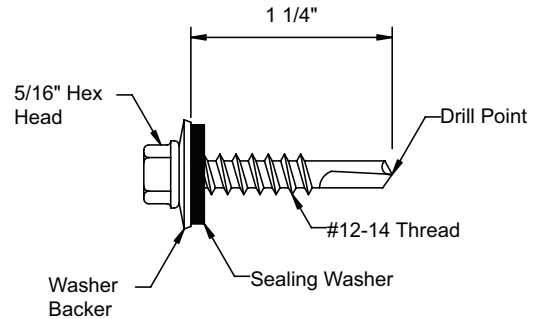

Part No. RF2 (Specify finish)

LAP FASTENER (for flashing attachment)

- 1/4" - 14 x 7/8" Self Drilling Screw
- EPDM Sealing Washer
- Corrosion resistant coating or alloy head
- Painted or mill finish head

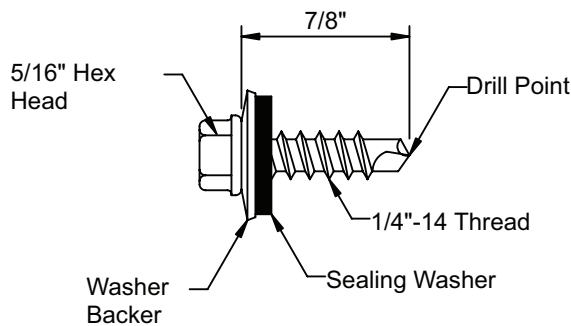

Part No. RF3 (Specify finish)

BLIND RIVET (for flashing joints)

- Stainless steel
- 1/8" dia. x 3/16" length

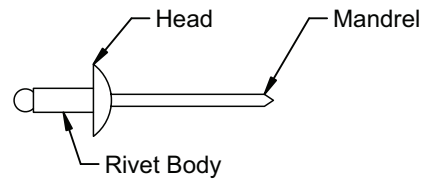

Part No. RF4

CLIP FASTENER

(for panel clip & eave plate attachment to steel purlins)

- 1/4" - 14 x 1" hex head, Self Drilling Screw
- Corrosion resistant plating

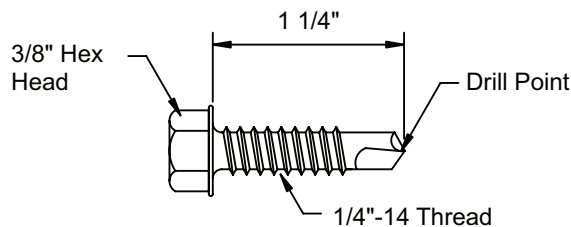

Part No. CF1

CLIP FASTENER

(for panel clip attachment to metal decking)

- #12 - 13, Phillips drive, Truss Head Screw
- Corrosion resistant coating

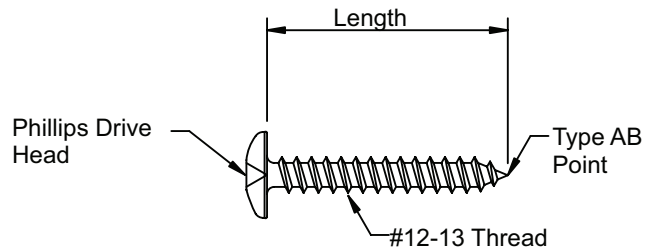

Part No. CF2 (Specify length)

8.0 STANDARD PARTS

CLIP FASTENER

(for panel clip attachment to wood decking)

- #10 - 12, Phillips drive, Pan Head Screw
- Corrosion resistant coating

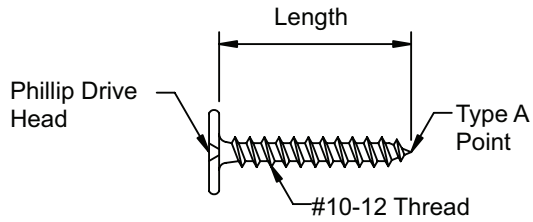

Part No. CF3 (Specify length)

SHOULDER FASTENER

(for floating rake plate attachment to steel purlins)

- 1/4" - 14 x 1 1/4" hex head, Self Drilling Screw
- Shoulder feature
- Corrosion resistant plating

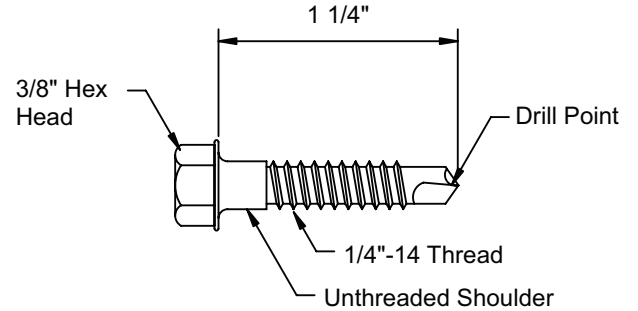

Part No. SF1

8.0 STANDARD PARTS

FLASHING SEALANT (for flashing laps & joints)

- 3/16" x 7/8" Butyl Tape Sealant
- Double Bead

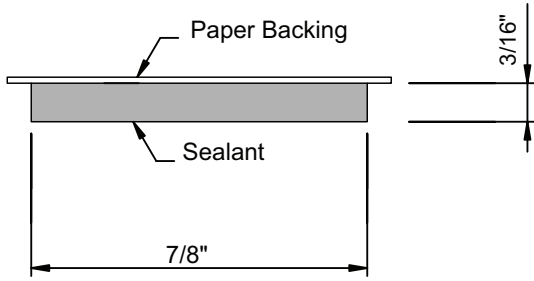

CROSS SECTION

Part No. RS2

ENDLAP SEALANT (for roof panel endlaps)

- 5/32" x 1 1/4" Butyl Tape Sealant
- Triple Bead

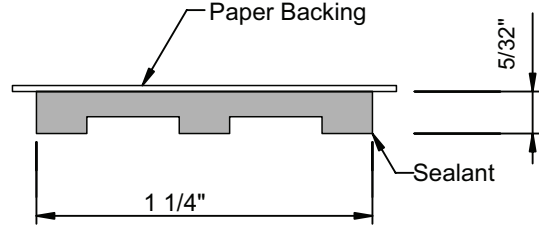

CROSS SECTION

Part No. RS1

TUBE SEALANT

- Urethane Gun Grade Sealant
- Color - brown, white, or grey
- 1/10 Gal. Tubes

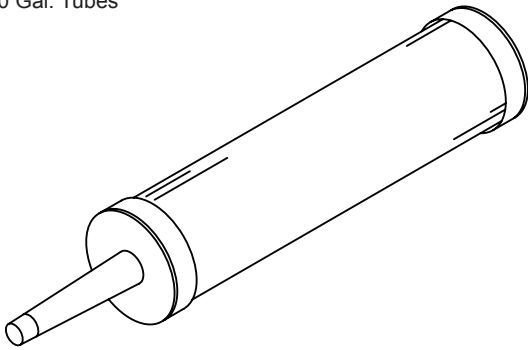

Part No. TS3 (Specify color)

SPACER BLOCK (for 24" wide panel)

- Extruded Polystyrene Foam
- 3/8", 5/8", or 1" Thick

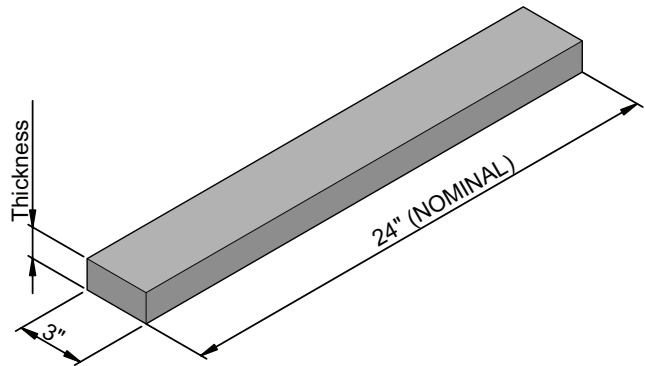

Part No. SB324 (Specify thickness)

9.0 ROOF INSTALLATION DETAILS

9.1 GENERAL

The following details provide graphic illustration of the roof assembly steps. The purpose is to instruct the erector in correct and efficient assembly of the roof system.

Because of the many variations in conditions, it is important that you review the job to identify and isolate the specific installation details required for your job.

Review the erection drawings for differences with these details. If differences exist, the erection drawings have precedence.

These details are arranged in a step-by-step sequence. Following this sequence ensures correct assembly and ensures that the part to be worked on will be readily accessible for the next assembly step.

Do not shortcut these assembly steps without careful consideration of the possibility of incorrect or omitted assembly and the resulting corrective rework.

To minimize confusion, the details are always oriented so that the view is from eave to ridge, with the starting rake at the left and finish rake at the right. Refer to the erection drawings to determine the required sheeting direction and rake conditions.

To help ensure weathertightness, the details emphasize proper fit-up, sealing and fastening. It is most important that only the specified sealants and fasteners be used for each condition and that they be installed correctly as shown on these details and the erection drawings.

Be sure that these critical instructions are reviewed often and the roof assembly is checked at each assembly step.



9.2 PREPARATION FOR ROOF PANEL INSTALLATION

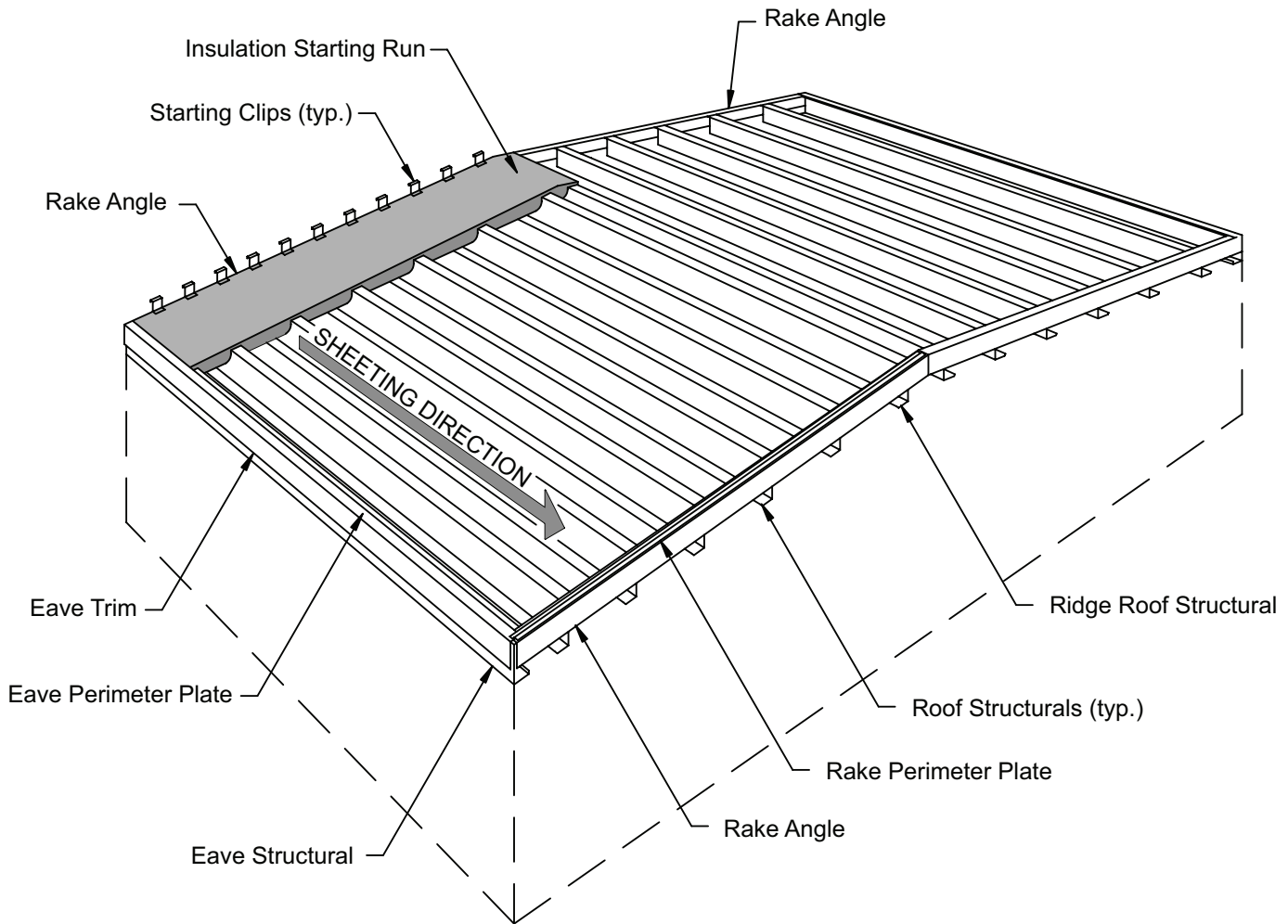

The details in this section will show the installation of the eave perimeter plate, rake perimeter plate, start clips, eave trim, eave sealant and the first run of insulation. These are parts that must be installed before the roof panel installation can begin.

This view shows the roof system oriented for a left-to-right sheeting direction. For right-to-left sheeting, reverse the parts orientation.

On this view, the starting rake is shown with starting clips (for a starting panel) and the finish rake is shown with a rake perimeter plate (for a termination panel). Some buildings may require a rake perimeter plate at the starting rake. Refer to the erection drawings for the required rake conditions.

If the insulation is not provided by the SL-324 manufacturer, consult with the project manager for insulation requirements.

9.2 PREPARATION FOR ROOF PANEL INSTALLATION

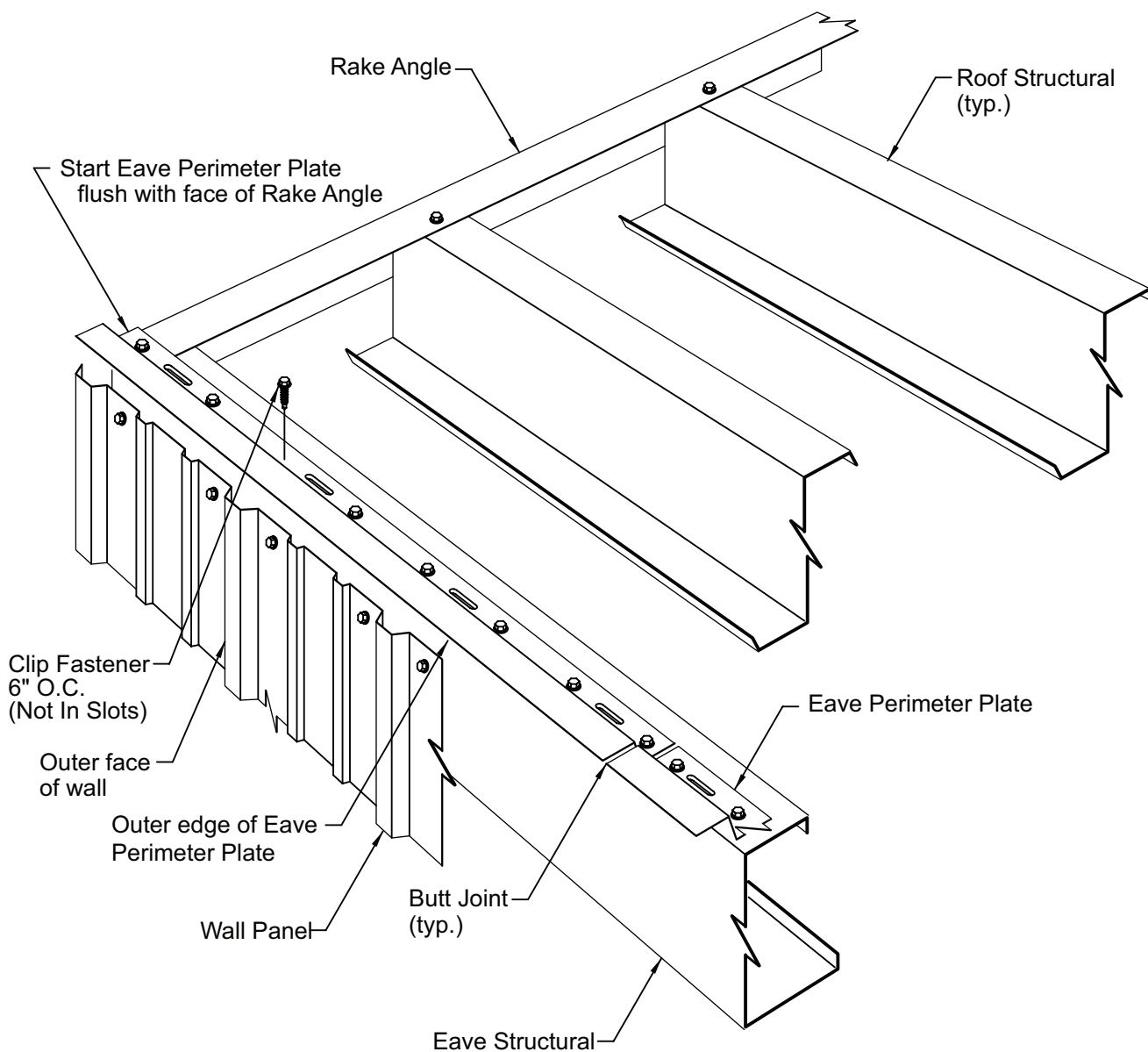

The eave perimeter plate provides a solid attachment surface for the eave end of the roof panel.

Install the starting and finish ends of the eave perimeter plates flush with outer face of rake angle.

The eave perimeter plate must be installed before the roof insulation is placed over the structurals.

Install the outer edge of the eave perimeter plate flush with the outside face of the wall panel.

Before installing the eave perimeter plate, check that the eave structural members are in a straight alignment from rake to rake. Shim the eave perimeter plate as necessary to provide a level roof line.

Tightly butt join the eave perimeter plates and fasten to the eave structural as shown.



9.2 PREPARATION FOR ROOF PANEL INSTALLATION

NOTE
Refer to erection drawings for structural fastener type and quantity

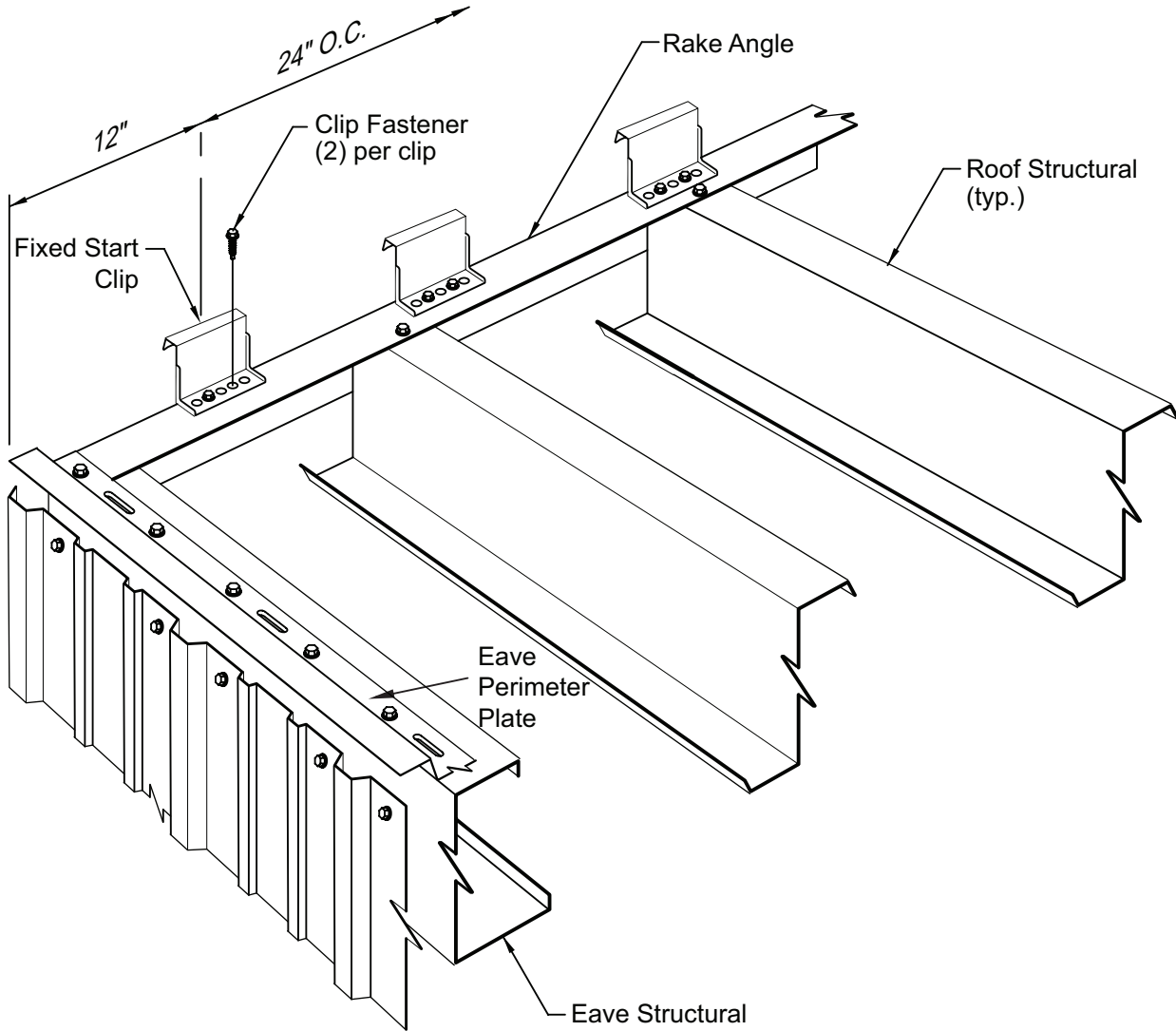

The appropriate height fixed clips are used as start clips.

Refer to the erection drawings and the structural layout (as described in Section 6.2) to determine the start dimension.

The position of the start clips establishes the starting roof panel alignment. It is very important that the start clips are installed in a straight line, parallel to the rake line.

If the rake angles have been installed true and square, the edge of the rake angle can be used to align the start clips.

If the rake angle is not true and square, a chalk line should be used to guide the installation of the start clips.

Locate the start clips at the spacing shown and fasten to the rake angle as shown.

9.2 PREPARATION FOR ROOF PANEL INSTALLATION

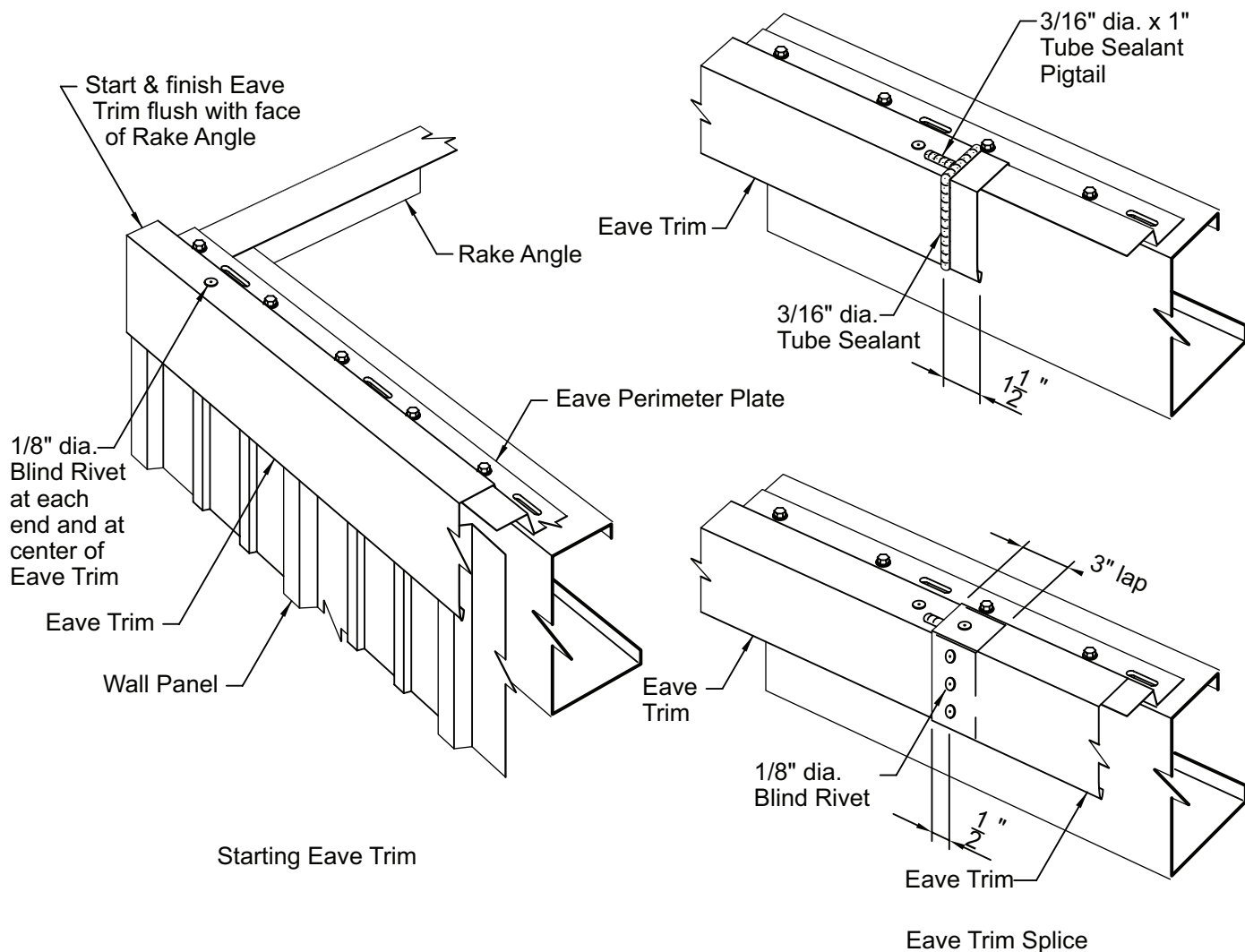

Place the upper lip of the eave trim over the eave perimeter plate as shown and align the face of the eave trim with the face of the wall panel.

Install the starting and finish ends of the eave trim flush with the ends of the eave perimeter plate.

The eave trim provides a water seal between the roof panel and the wall panels. All laps of the eave trim must be sealed with tube sealant and rivets as shown to minimize water entry.

Fasten each piece of eave trim to the eave plate with three blind rivets. The rivets will hold the trim in position until the roof panels are installed and fastened.

9.2 PREPARATION FOR ROOF PANEL INSTALLATION

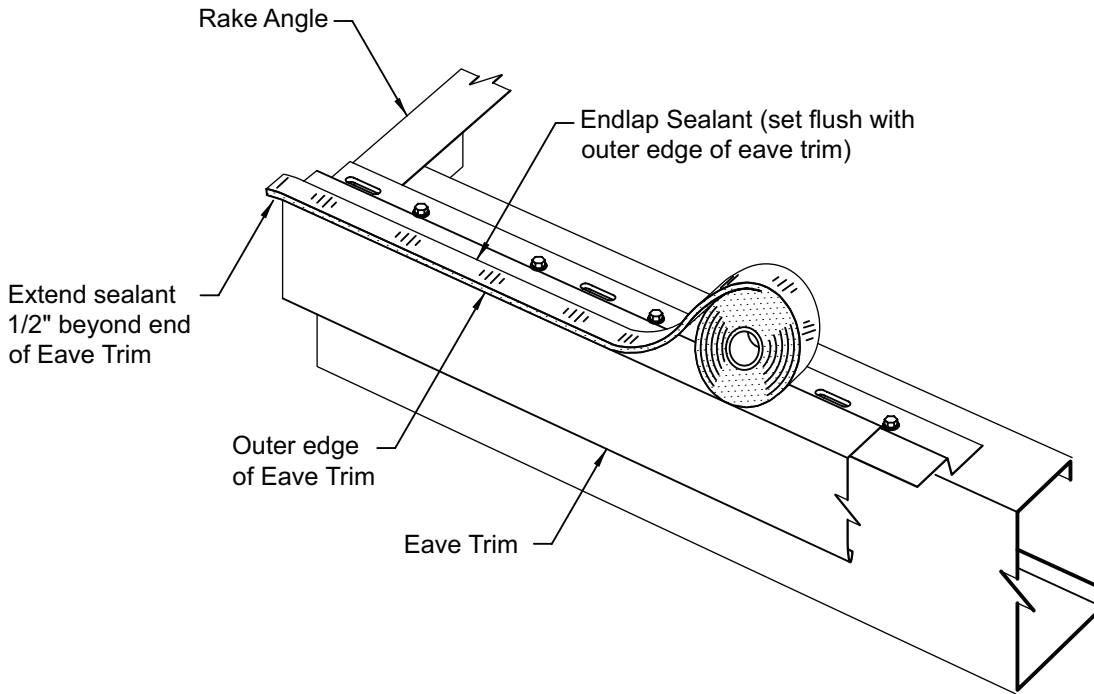

Apply a continuous strip of endlap sealant along the top edge of the eave trim.

Align the outer edge of the sealant flush with the outer edge of the eave trim.

Do not remove the paper backing from the sealant at this time.

Until the roof panels are installed, the eave sealant is vulnerable to damage from foot traffic or dragging material over the eave. Do not step on or otherwise damage the sealant.

9.2 PREPARATION FOR ROOF PANEL INSTALLATION

Note: Insulation clamping strap and fasteners are not provided with the roof system.

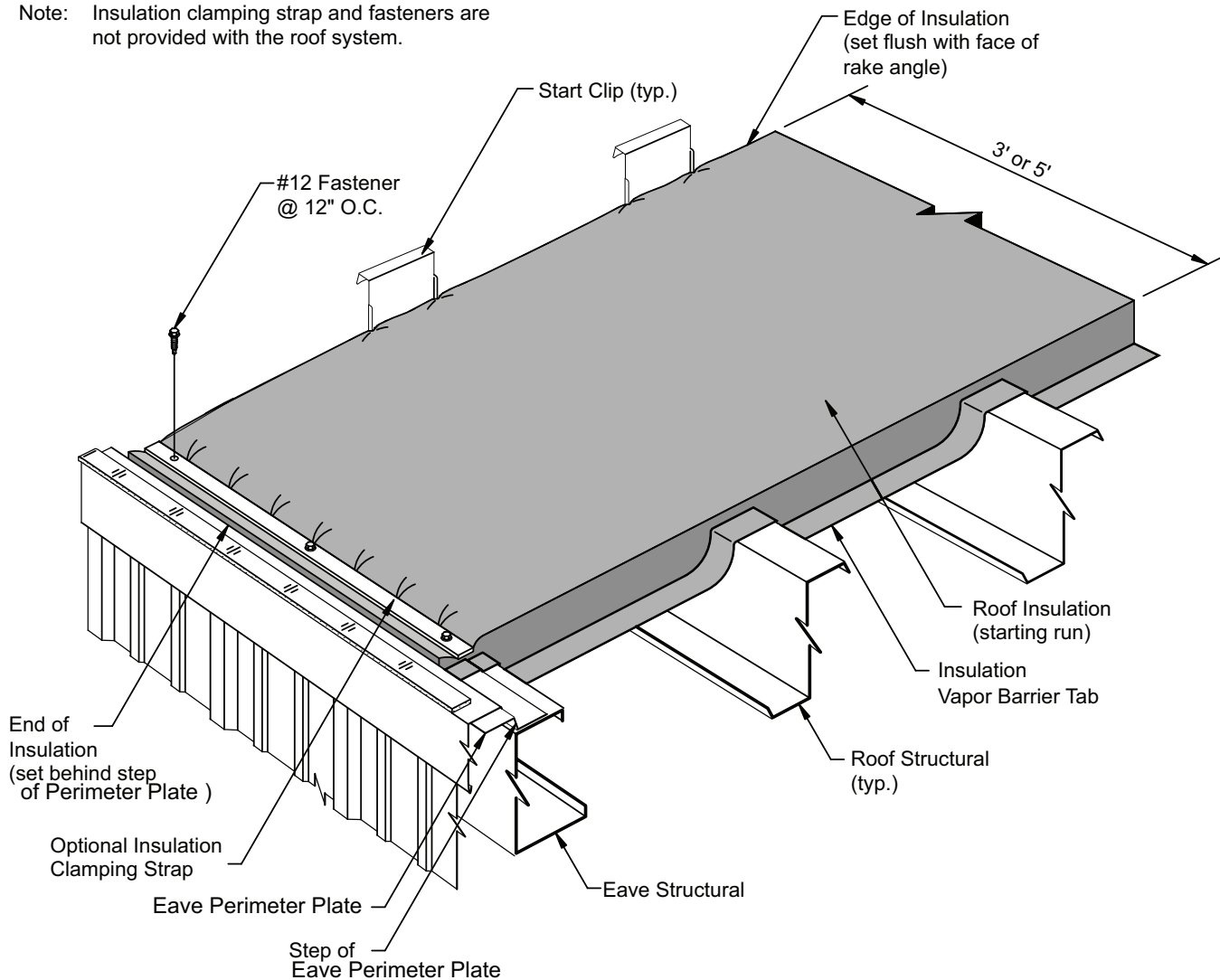

Refer to the erection drawings to determine the specific insulation required for the project. In all cases refer to the insulation manufacturer's instructions for proper insulation installation and vapor seal assembly. This detail shows fiberglass blanket insulation, which is the most commonly used insulation for metal standing seam roofs.

The leading edge of each insulation run should extend approx. 12" beyond the leading edge of the roof panel. This will allow for easy assembly of the vapor barrier seal between insulation runs.

With four foot or six foot wide insulation, the first run should be installed to only cover three feet or five feet respec-

tively. The extra foot of width can be cut or lapped over the rake.

Use double-faced tape along the backside of the eave strut and along the rake angle to hold the insulation in place until the roof panel is installed.

In **high wind areas** or when using **high stand-off** clips, use the metal insulation retainer straps to secure the insulation to the low flange of the eave plate. In all cases do not extend the end of the insulation onto the high flange of the eave perimeter plate.



9.3 ROOF PANEL INSTALLATION

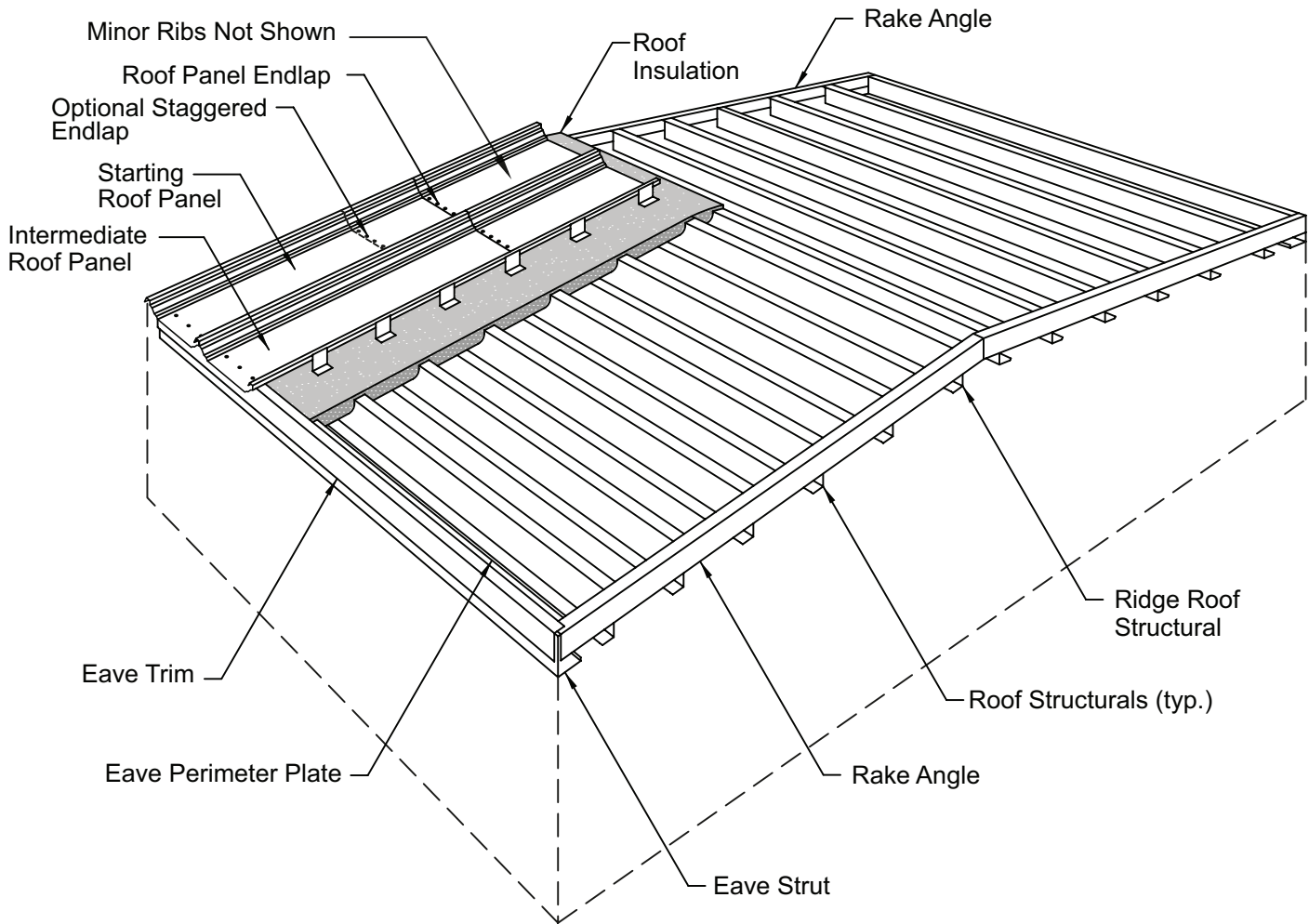

The details in this section show the installation of the starting and intermediate roof panels.

The termination roof panels require specific installation and are shown in a later section.

The roof panel endlap details are shown as an integral part of the roof panel installation. If the project does not require roof panel endlaps, the endlap details are clearly identified and can be disregarded.

9.3 ROOF PANEL INSTALLATION

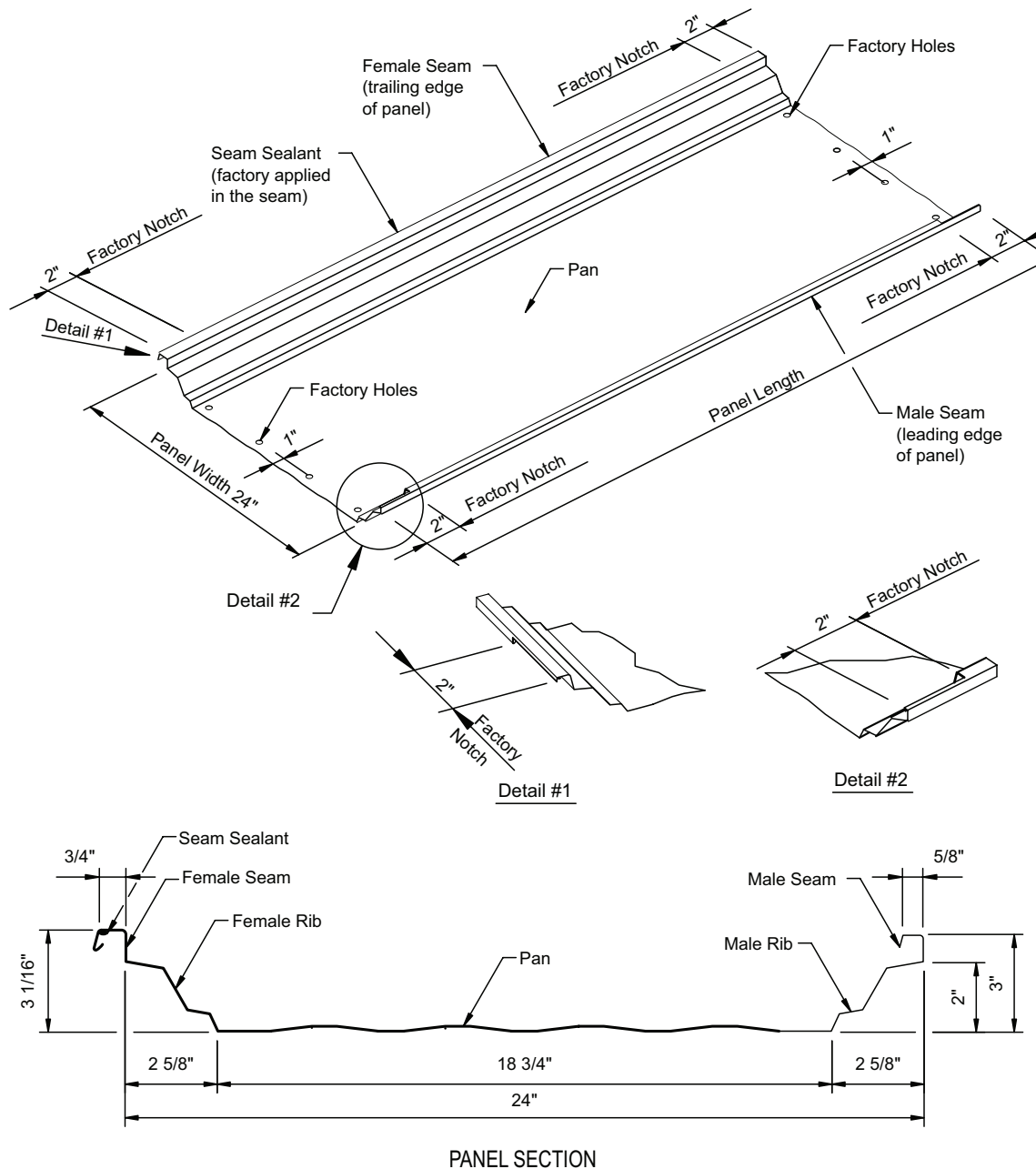

Throughout these instructions the references to the panel will be made using the terms shown on the above illustration.

The factory punched holes may not be used at the eave unless there is gutter or eave trim. It is acceptable to leave them open.

The SL-324 roof panel is designed, so it can be sheeted in either direction, (left-to-right) or (right-to-left). Check the erection drawings and job conditions to determine if the roof must be sheeted in a specific direction.

The leading edge of the roof panel is the edge towards the sheeting direction. On the SL-324 roof panel, the male seam is the always the leading edge.

Before loading the panels onto the roof structurals, orient the panels so that the male seam is the leading edge.



9.3 ROOF PANEL INSTALLATION

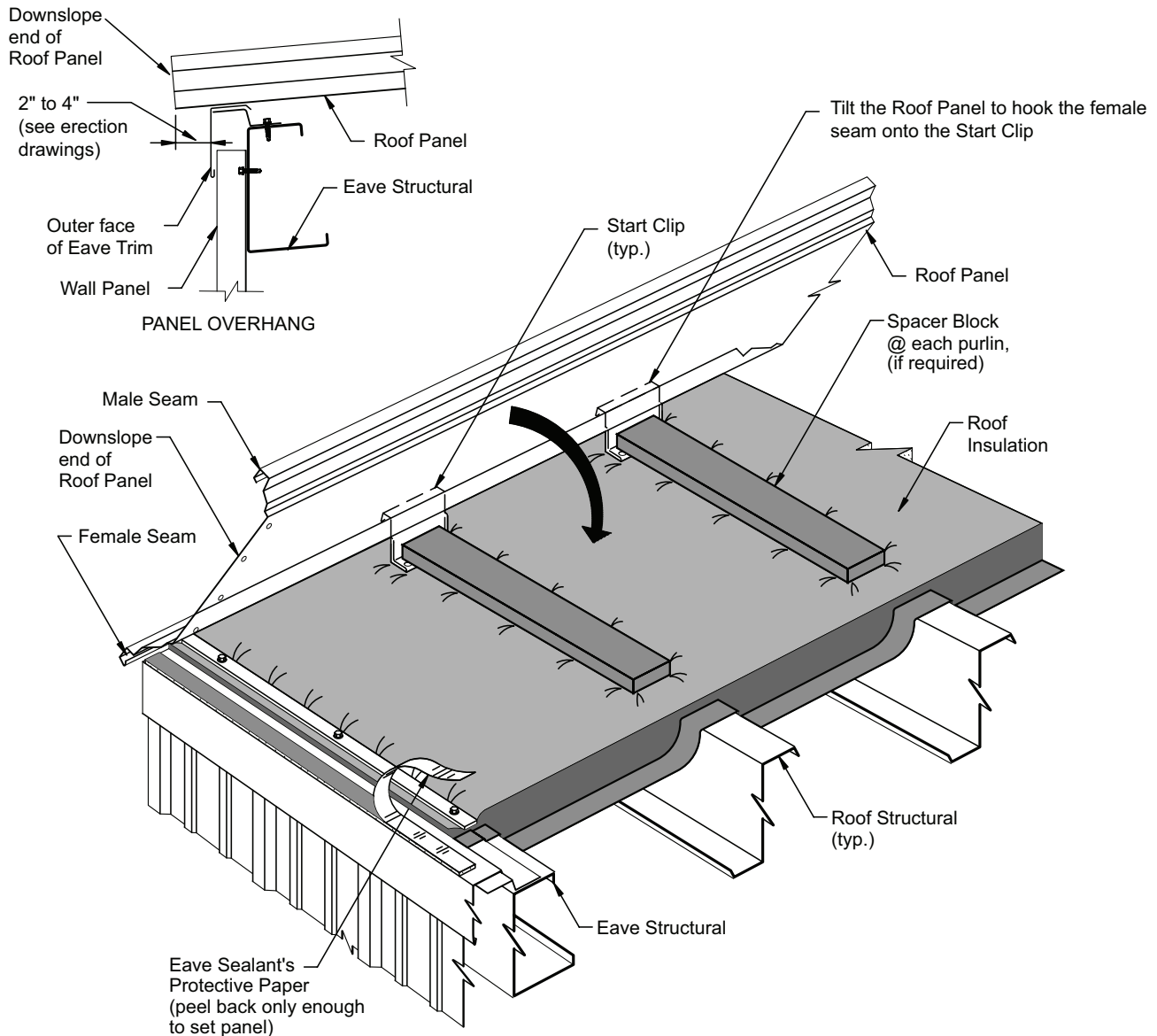

The roof panel's eave overhang dimension is critical as it establishes the location of endlaps and ridge cover attachment points.

Position the female edge of the panel over the start clips and position the end of the panel 2" +/- beyond the face of the eave trim.

The end of the roof panel extends 2" +/- beyond the face of the eave trim unless another dimension is specified on the erection drawings.

Tilt the panel as shown so the female seam can be hooked over the start clips. Check that each clip is hooked inside of the seam.

If insulation spacer blocks are required, place the blocks on top of the insulation directly over the roof structurals. Spacer blocks are not required at the eave structural.

Do not completely remove the eave sealant's protective paper at this time.

9.3 ROOF PANEL INSTALLATION

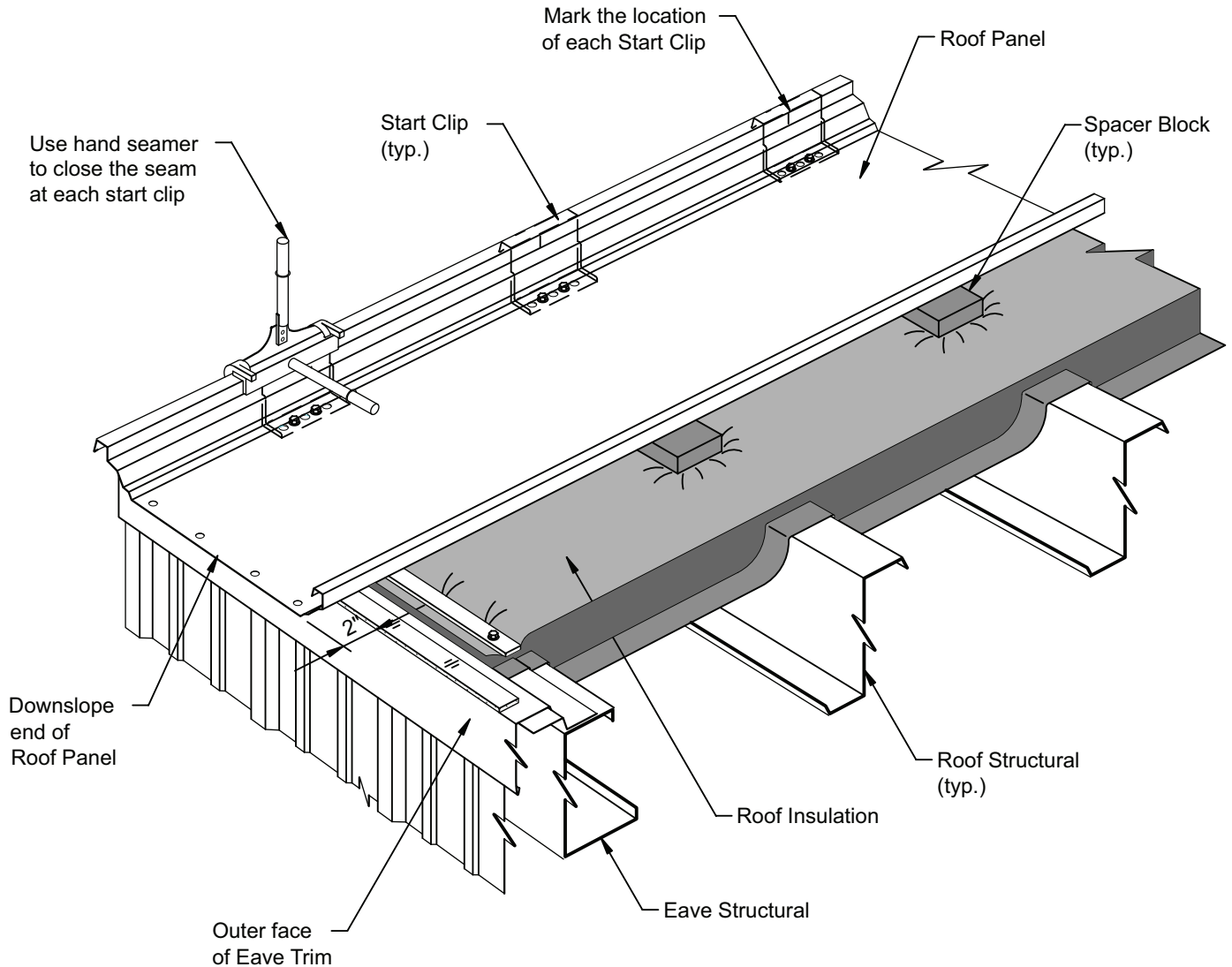

Verify that the roof panel's overhang dimension is correct and verify that the roof panel is aligned parallel to the rake line. Raise the leading corner of the panel and remove the protective paper from the eave sealant.

Rotate the panel down to rest on the spacer blocks or insulation.

Using the hand seaming tool, **close the panel seam over each start clip**. For proper operation of the seaming tool, refer to the Seaming Guide provided with the seamer.

Mark the roof panel's vertical leg at each clip location. This will guide the later installation of rake trim fasteners to ensure they are not installed through the clip tabs.



9.3 ROOF PANEL INSTALLATION

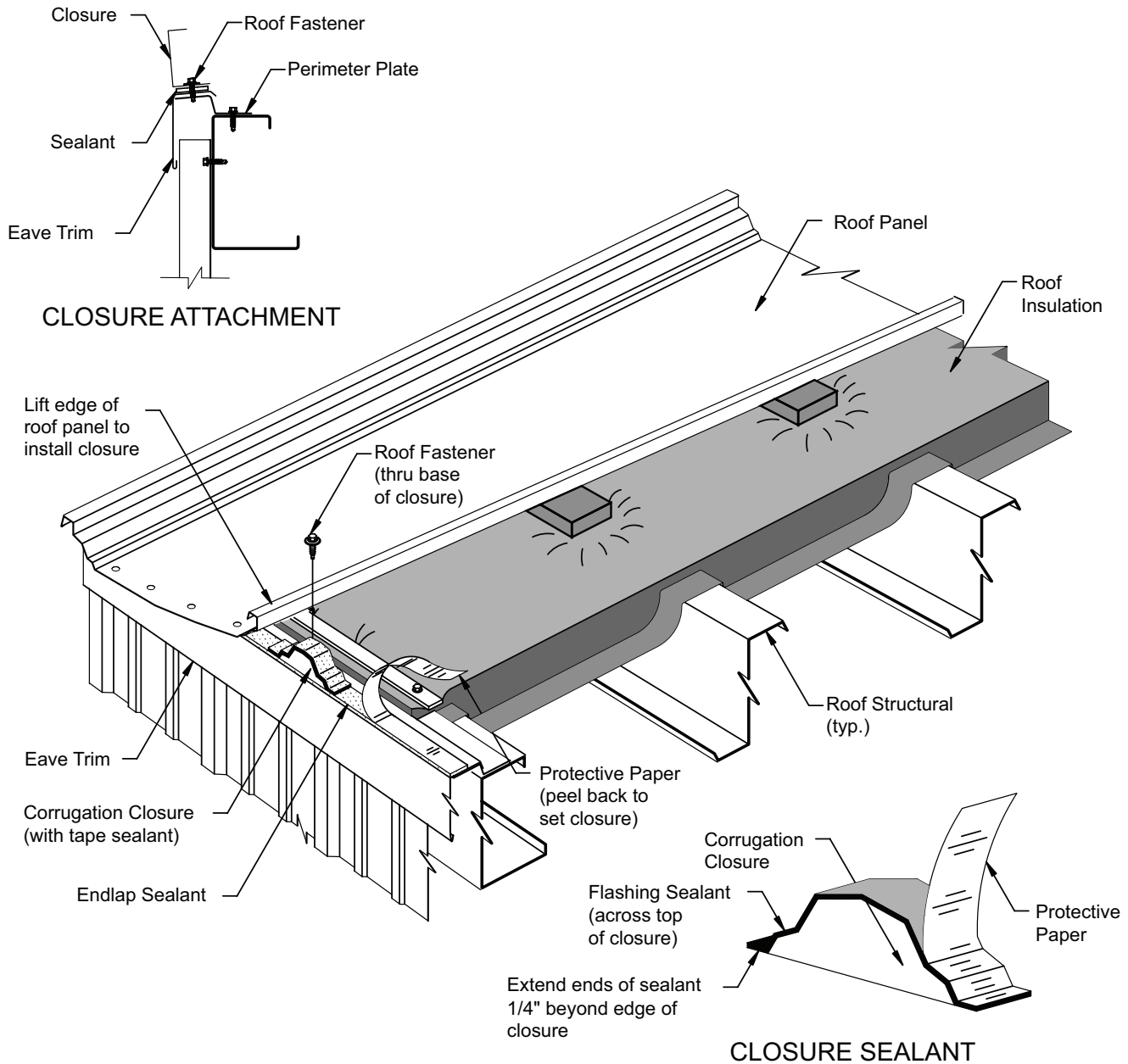

Prepare the corrugation closures by applying flashing sealant along the top surfaces as shown in the above illustration. Remove the protective paper.

Check that the closure is centered to the roof panel's edge.

Peel back the protective paper from the eave sealant as shown to clear the corrugation closure.

Fasten the closure to the eave perimeter plate with a roof fastener installed through the hole in the base of the closure.

Pick up the corner of the roof panel and place the closure into the panel corrugation and on top of the eave sealant.

9.3 ROOF PANEL INSTALLATION

NOTE
Refer to erection drawings for clip fastener type and quantity

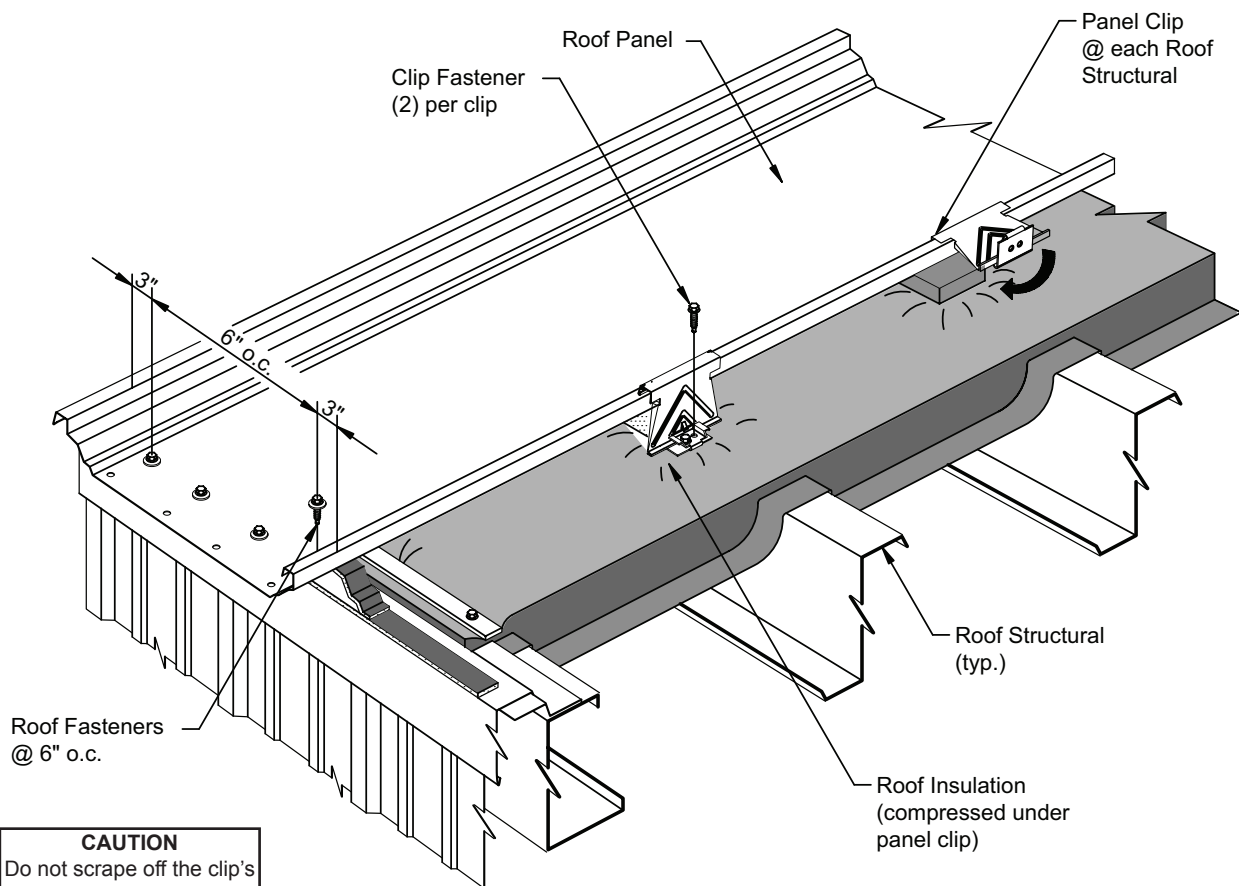

CAUTION
Do not scrape off the clip's sealant assembling to the roof panel.

Before fastening the roof panel to the eave plate and fastening the leading edge of the panel with the panel clips, check that the panel coverage is correct and the leading edge of the panel is straight and parallel to the rake line.

Fasten the eave end of the panel with (4) roof fasteners spaced 6" O.C. as shown.

Position the fasteners to penetrate through the center of the sealant, through the eave trim and into the eave plate.

Install roof panel clips to the leading edge of the roof panel at each roof structural. Panel clips are not required at the eave structural.

To install the clips, tilt the clip so that its tab can be hooked over the edge of the roof panel's male seam. Position the clip's base so that the clip fasteners can be installed through the holes in the base and into the roof structural, then rotate the clip down into the vertical position.

When fiberglass roof insulation is used, the panel clips normally set on top of the insulation and the insulation is compressed between the clip's base and the top of the roof structural. In all cases, refer to the erection drawings to determine the required insulation assembly and the relationship of the panel clips to the insulation.

Specific panel clip details are shown on the following page.



9.3 ROOF PANEL INSTALLATION

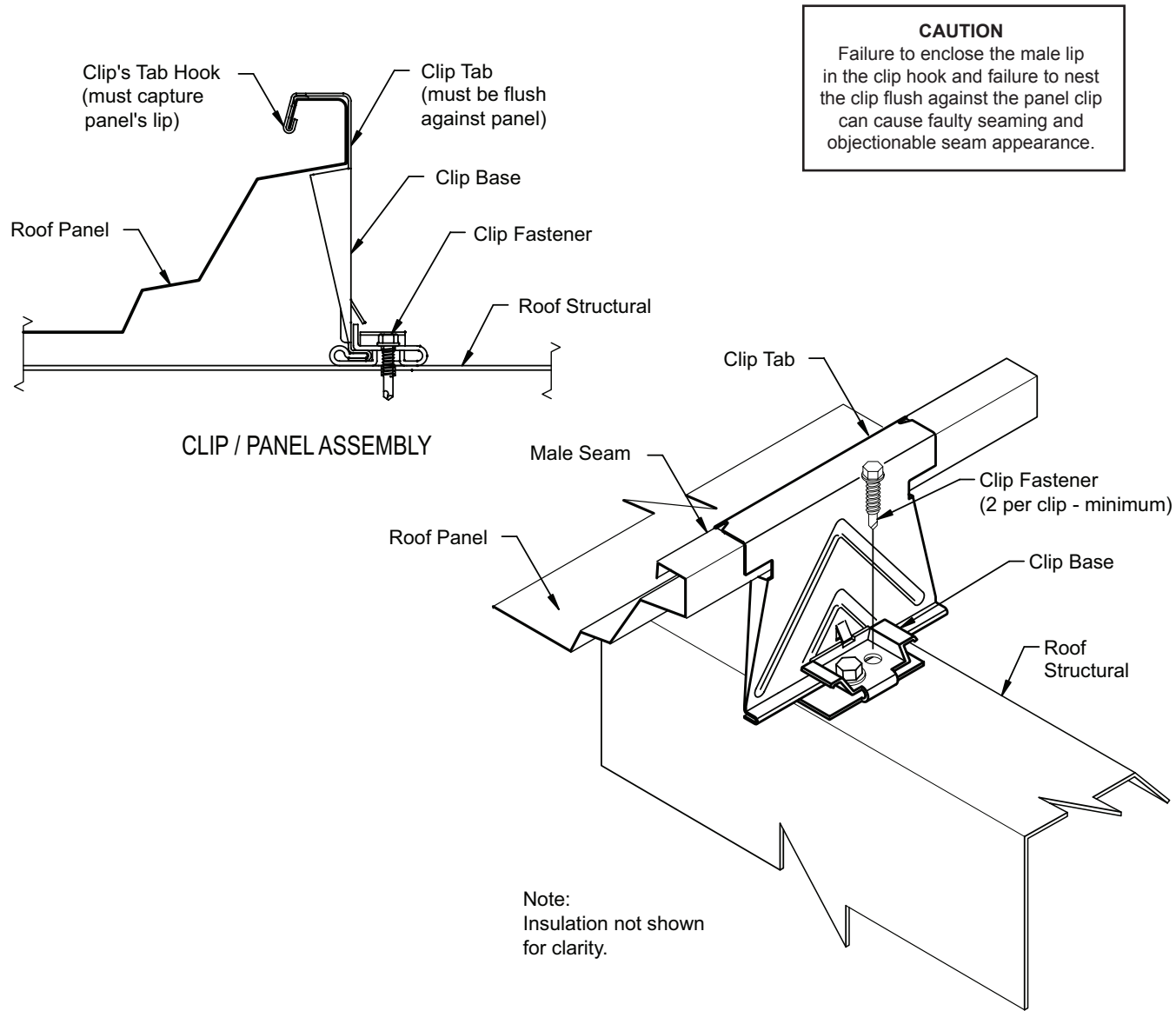

Panel clips are available as floating clips or fixed clips and are available in different stand-off heights. Refer to the erection drawings to determine the type of clip and quantity of fasteners required for each roof condition.

Panel clip fastener type and quantity vary according to the roof structural material and roof load requirements. Refer to the erection drawings for the required type and quantity of panel clip fasteners.

Check that the panel clip's tab is seated tightly around the roof panel's seam and that the panel clip's hook has captured the panel's lip.

Check that the clip fasteners are equally spaced through the clip base holes and are securely engaged into roof structural.

Check that the clip is vertical and that the base is set square and firmly over the roof structural.

9.3 ROOF PANEL INSTALLATION

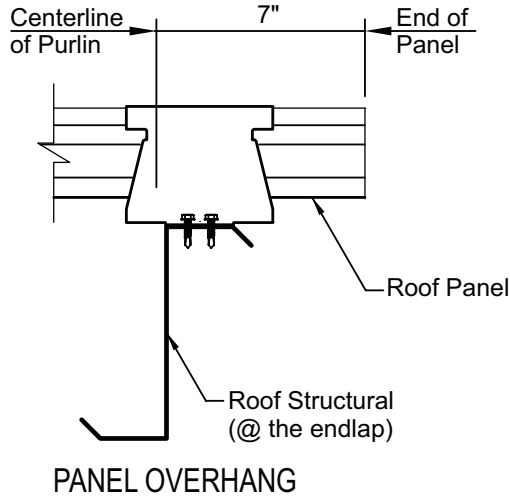

There are two types of endlap details. One is the **In-Line Endlap** and the other is the **Staggered Endlap** installation.

The following details for the first run of panel are applicable to both installations.

Where the staggered endlap is addressed a separate instruction is provided and noted as optional staggered end lap.

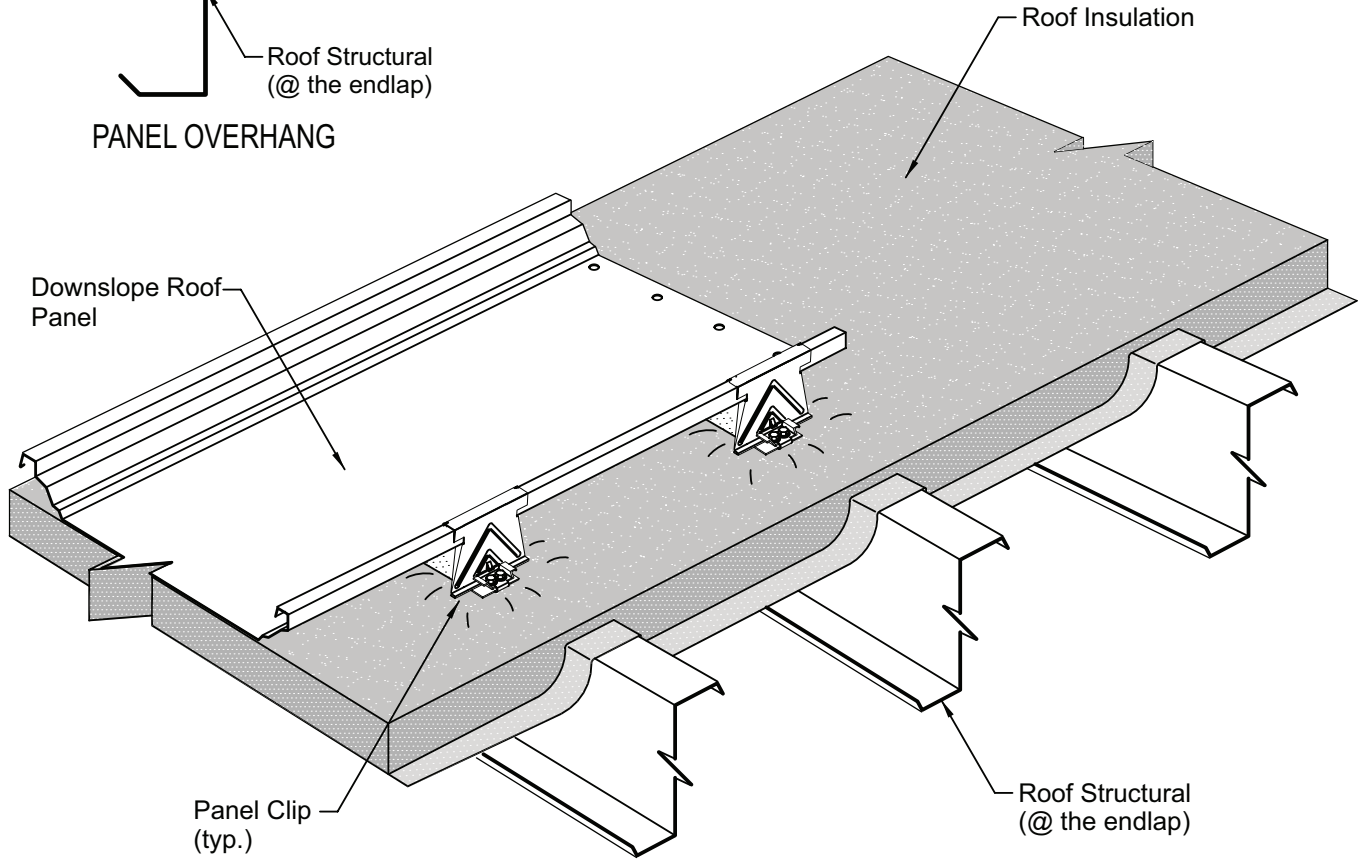

With the eave end of the roof panel attached, measure the panel overhang at the purlin (see illustration).

The panel should extend 7" beyond the center line of the purlin or joist.

If the panel overhang is not within this range, call the metal building supplier before proceeding with the installation of roof panels. Also reference the erection drawings for prescribed dimensions.



9.3S ROOF PANEL INSTALLATION

2" Factory panel notch on female side of the panel requires a 6" bead of sealant at end of staggered panel

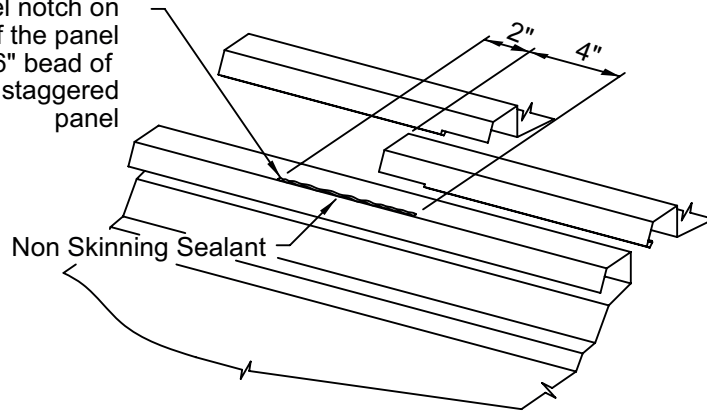

Detail 1

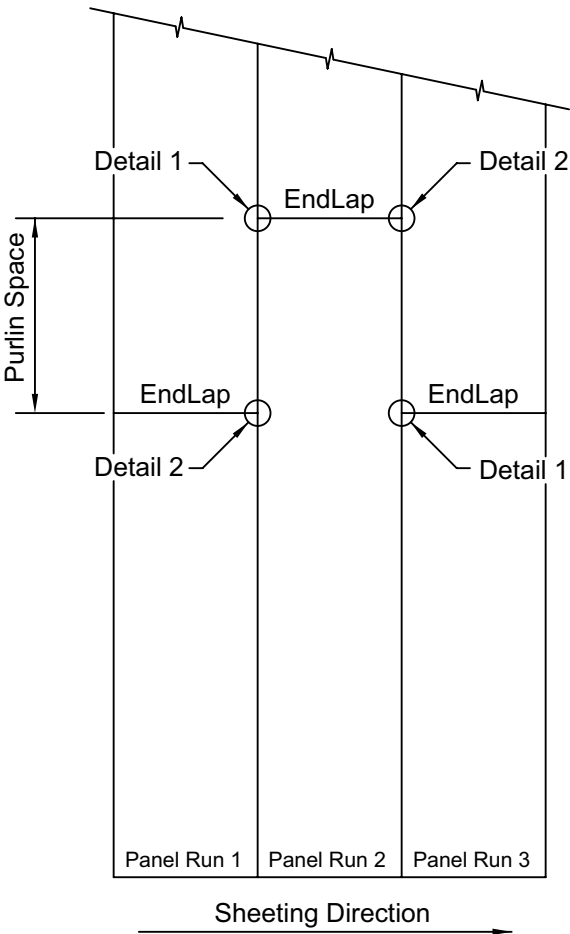

4" Tape sealant centered on 2" factory notch

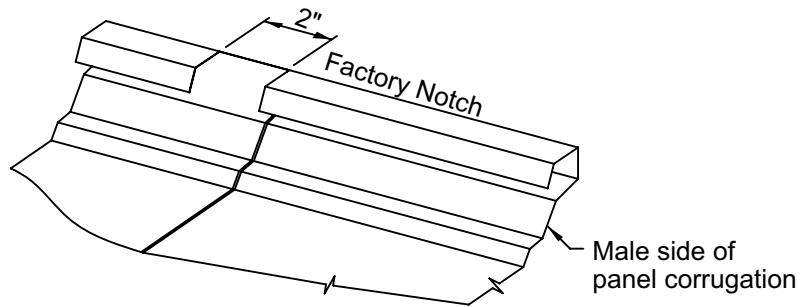

Detail 2

All previous notes and details for the straight line endlap will remain the same for the first panel run.

All endlaps with or without splice plates will be sealed as shown in the previous instructions and occur over a purlin space.

If the second panel endlap is staggered, a combination of tape sealant and non skinning sealant will be required as shown in detail 1 and 2.

9.3 ROOF PANEL INSTALLATION

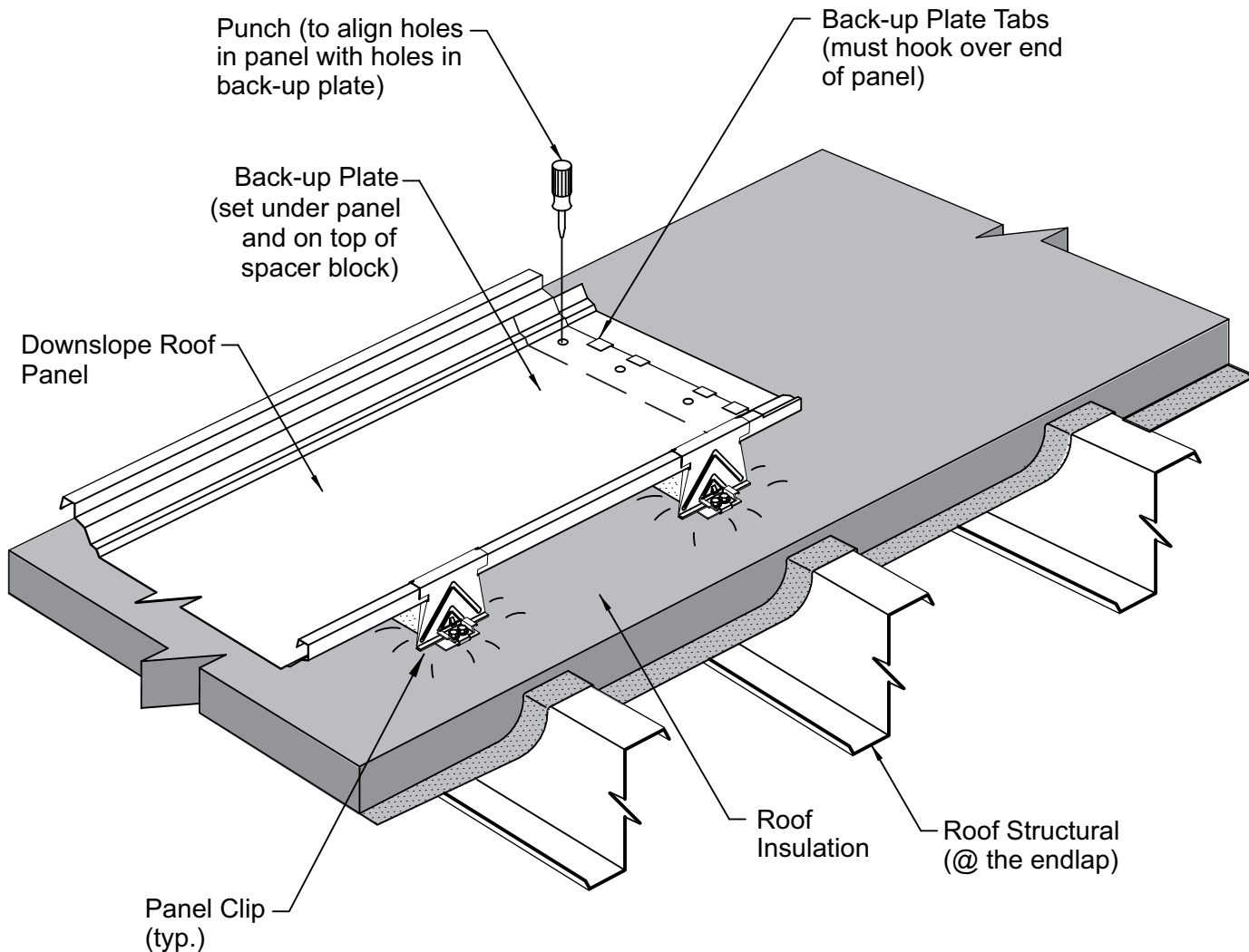

Slide the back-up plate under the roof panel, as shown.

The back-up plate must be set over the top of the roof structural. If insulation spacer blocks are used, the back-up plate must be set over the spacer block.

The back-up plate's tabs must hook over the end of the roof panel.

Use punches to align the holes in the back-up plate with the factory punched holes in the roof panel.



9.3 ROOF PANEL INSTALLATION

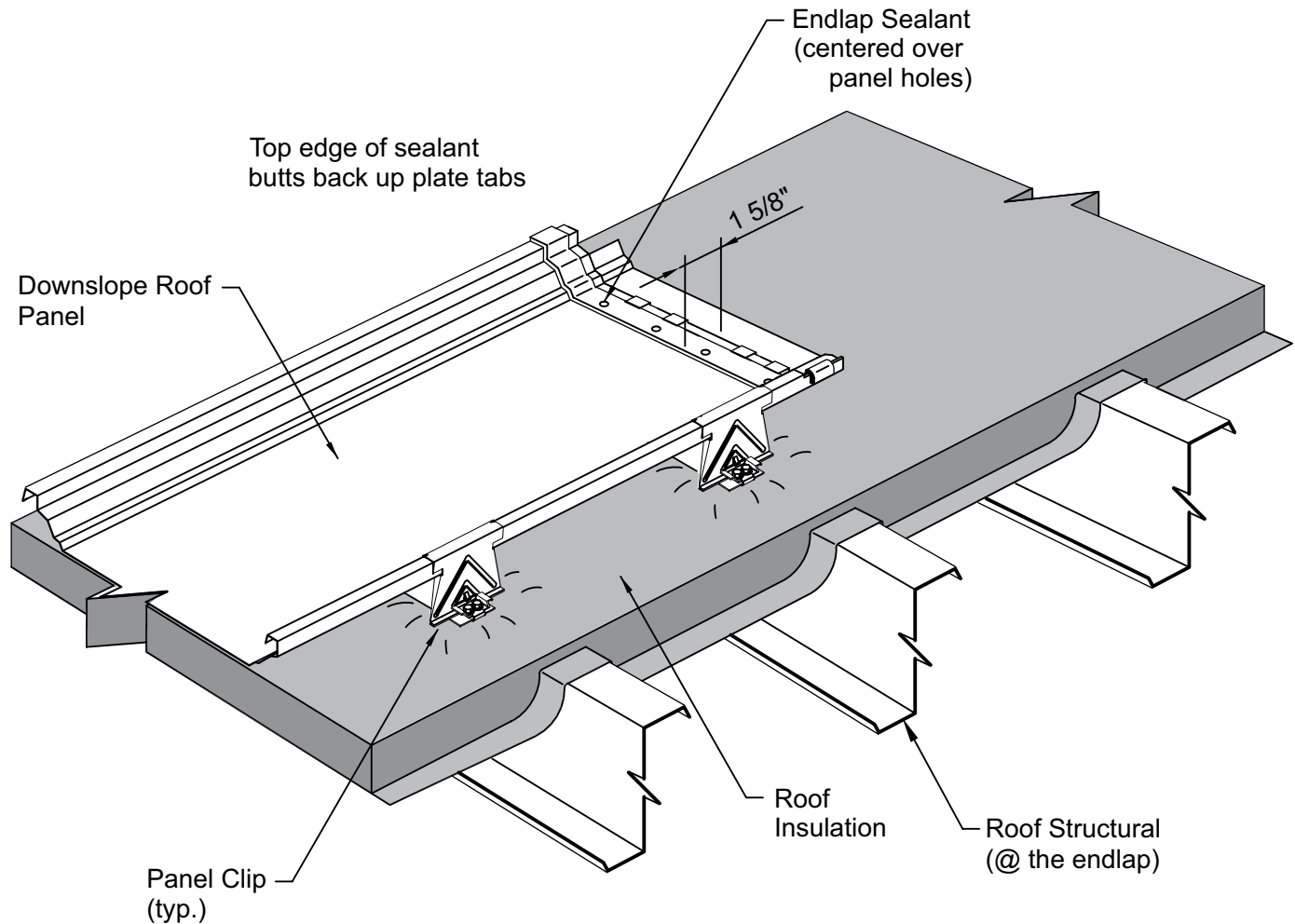

The proper placing of the endlap sealant is critical to the weathertightness of the roof endlaps.

Before installing the endlap sealant, the roof panel's surface must be wiped clean and dry.

Position the sealant so that its downslope edge is uniformly 1 5/8" from the end of the panel. The sealant must be centered over the roof panel's factory punched holes.

Install a continuous strip of endlap sealant along the end of the roof panel, as shown.

Check that the sealant fully contacts the roof panel's surface and that it is completely fitted into the panel corners and around the seams.

The sealant's protective paper helps to retain the sealant's shape during installation and protects the sealant's surface from damage and contamination. Do not remove the protective paper until immediately before the installation of the up-slope roof panel.

Specific endlap sealant details are shown on the following page.

9.3 ROOF PANEL INSTALLATION

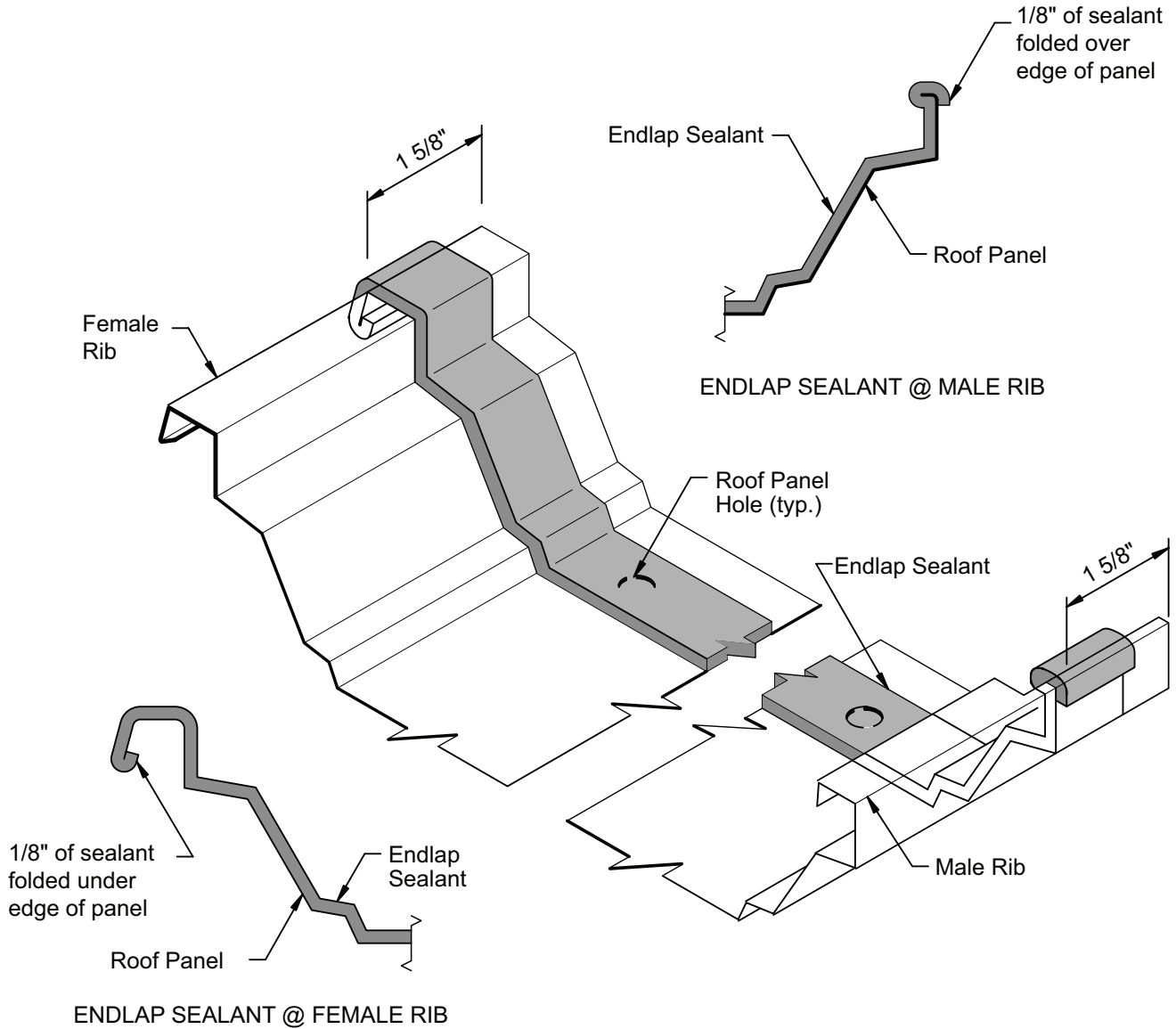

Cut the endlap sealant to be fitted around the roof panel's seams as shown.

After the sealant is correctly positioned, uniformly press the sealant against the roof panel's surface to assure adhesion. Do not use excess pressure which can thin the sealant.

Check that the 1/8" ends of the sealant are correctly folded around the roof panel's edges. Excess sealant in the roof panel seams will cause difficult panel assembly. Remove any excess sealant.



9.3 ROOF PANEL INSTALLATION

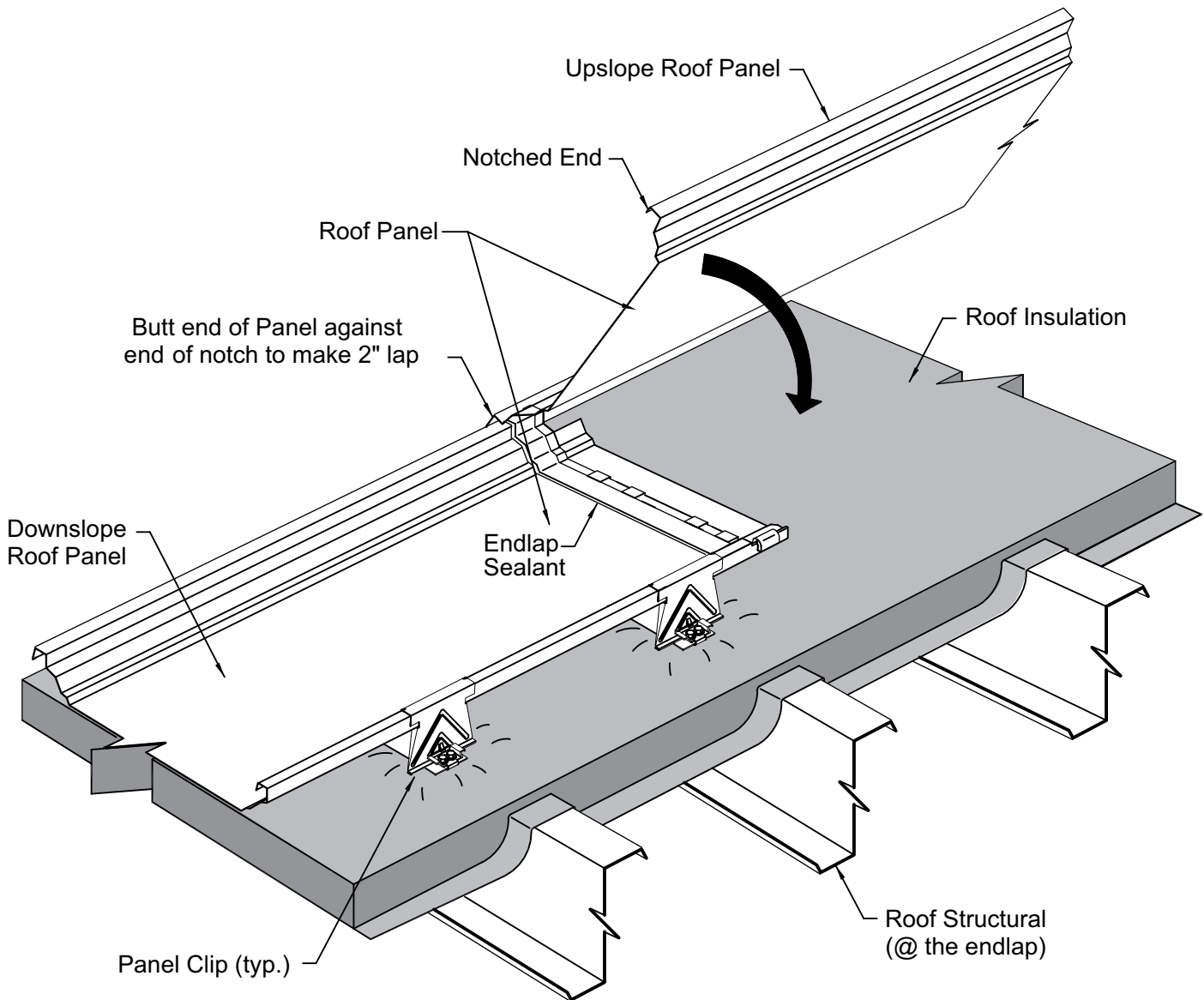

Wipe dry and clean the underside surface of the up-slope roof panel.

At the seams, the end of the up-slope roof panel should butt against the notch on the down-slope roof panel.

Remove the protective paper from the installed endlap sealant.

Check that the up-slope roof panel will correctly lap over the endlap sealant.

Position the end of the up-slope roof panel to make a 2" lap over the down-slope roof panel.

9.3 ROOF PANEL INSTALLATION

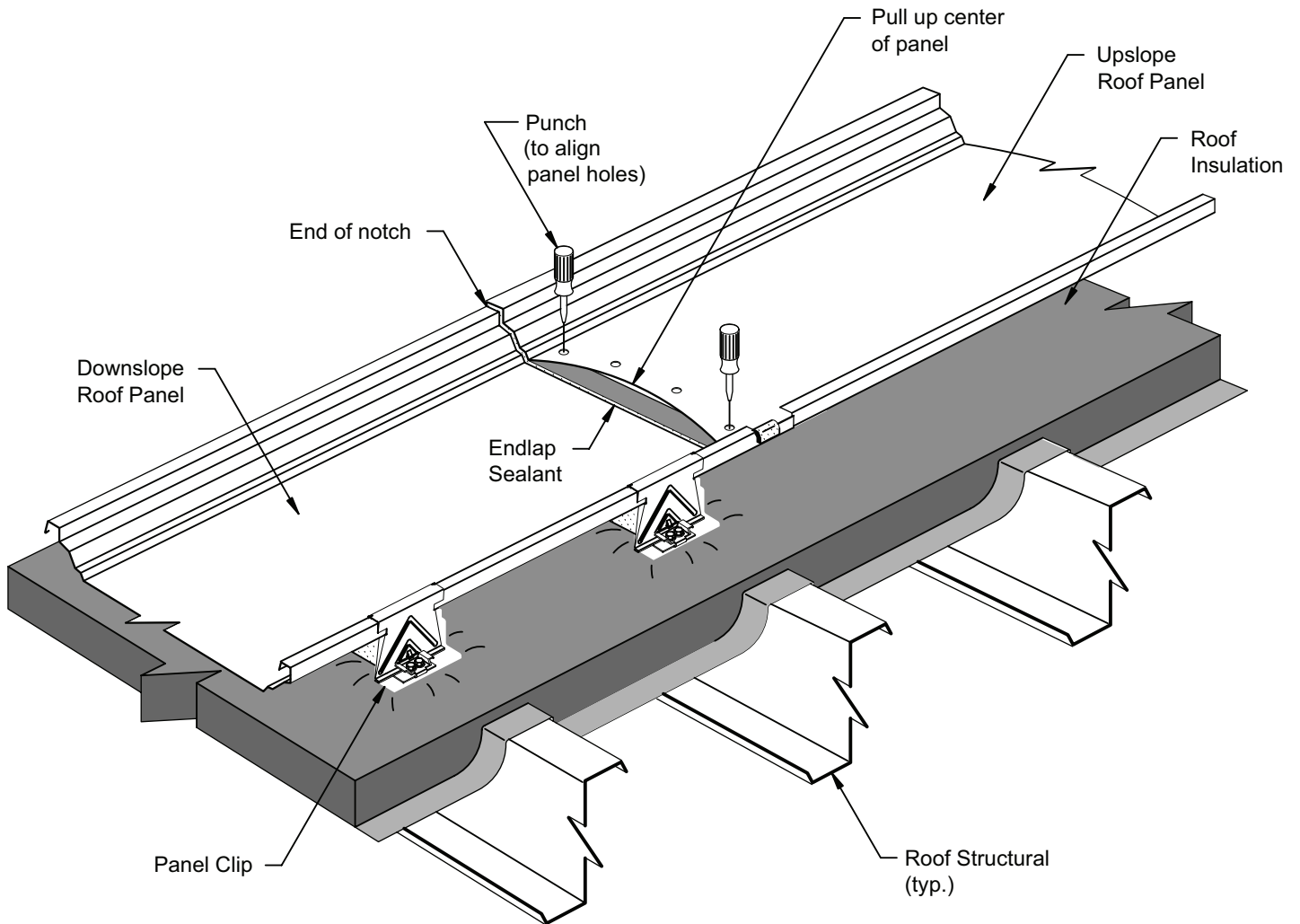

Lower the up-slope roof panel to lap onto the down-slope roof panel.

not disturb the position of the sealant while inserting and removing the punch.

While lowering the up-slope roof panel, bow the end of the panel by pulling up on its center. This will allow the panel to more easily nest into the down-slope panel.

Do not remove the punches from the roof panel holes until after the seam clamps have been installed.

Use punches to align the factory punched holes of the lapping panels. The punch will have to penetrate through the endlap sealant and into the holes in the back-up plate. Do



9.3 ROOF PANEL INSTALLATION

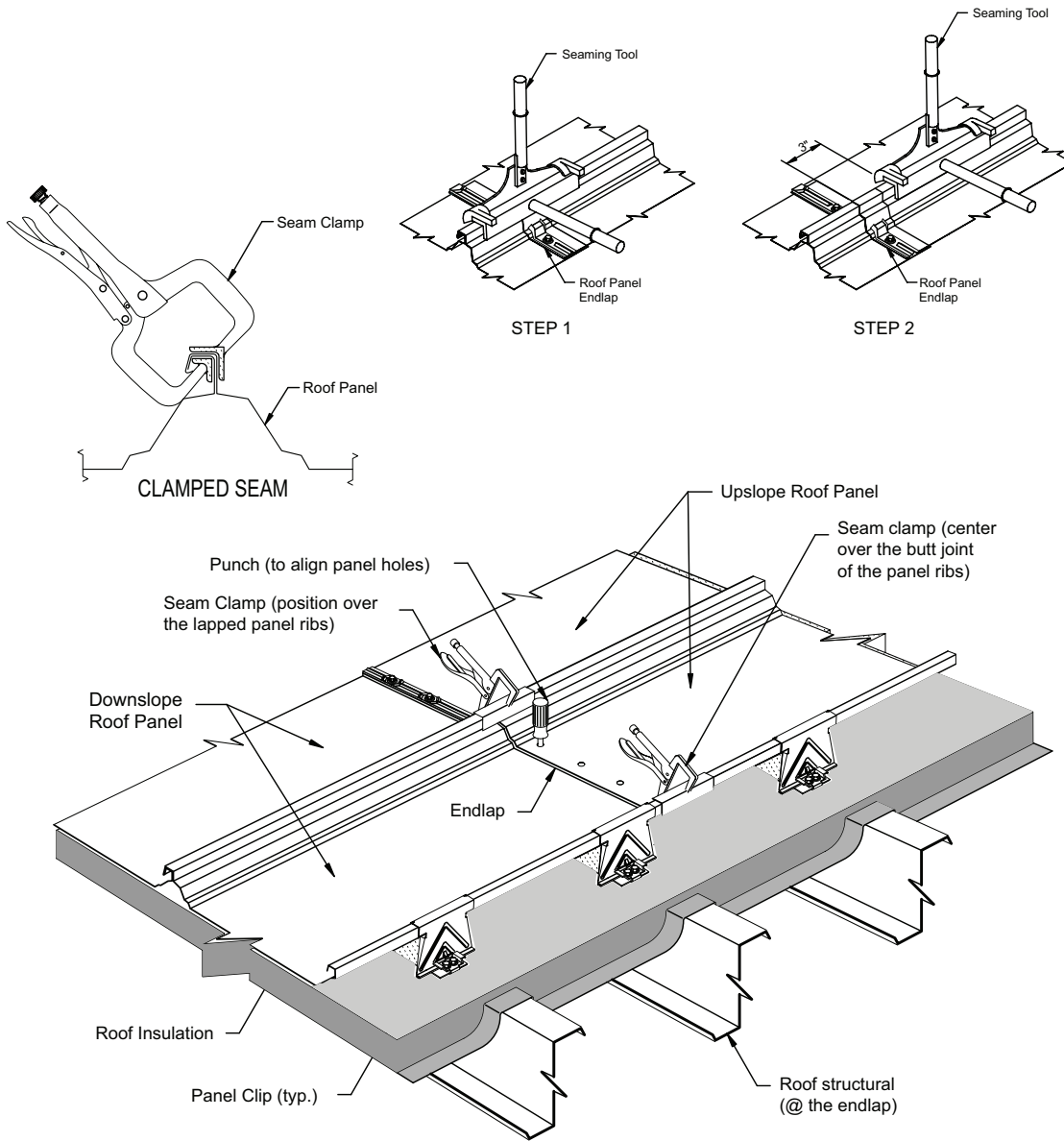

Use the seam clamps to draw the lapping panel seams together, as shown.

Check that the clamp jaws are correctly aligned to the seam before closing the clamp. Misaligned clamps can distort and damage the roof panel seams.

Slowly close the clamp to allow the sealant to flow between the lapped seams.

With the seam clamps installed, uniformly press down on the up-slope panel to close the panel lap and to assure adhesion to the endlap sealant.

Do not remove the seam clamps until after the optional endlap cinch strap has been installed. They may or may not be shown on the following steps.

Hand seam at lap - refer to seaming guide for *specific instructions*.

9.3S ROOF PANEL INSTALLATION OPTIONAL STAGGERED ENDLAP

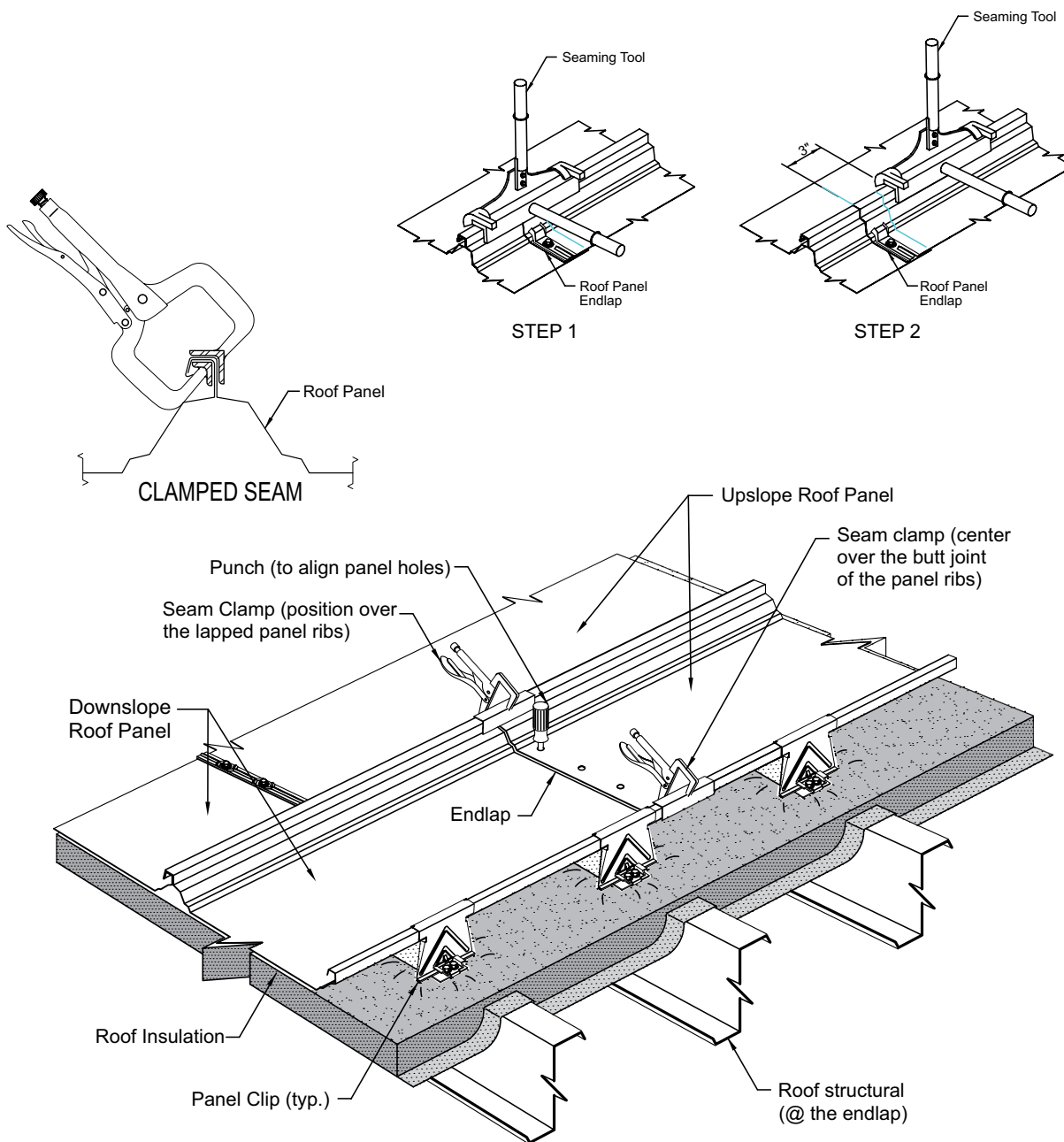

Use the seam clamps to draw the lapping panel seams together, as shown.

Check that the clamp jaws are correctly aligned to the seam before closing the clamp. Misaligned clamps can distort and damage the roof panel seams.

Slowly close the clamp to allow the sealant to flow between the lapped seams.

With the seam clamps installed, uniformly press down on the up-slope panel to close the panel lap and to assure adhesion to the endlap sealant.

Do not remove the seam clamps until after the optional endlap cinch strap has been installed. They may or may not be shown on the following steps.

Hand seam at lap - refer to seaming guide for **specific instructions**.



9.3 ROOF PANEL INSTALLATION

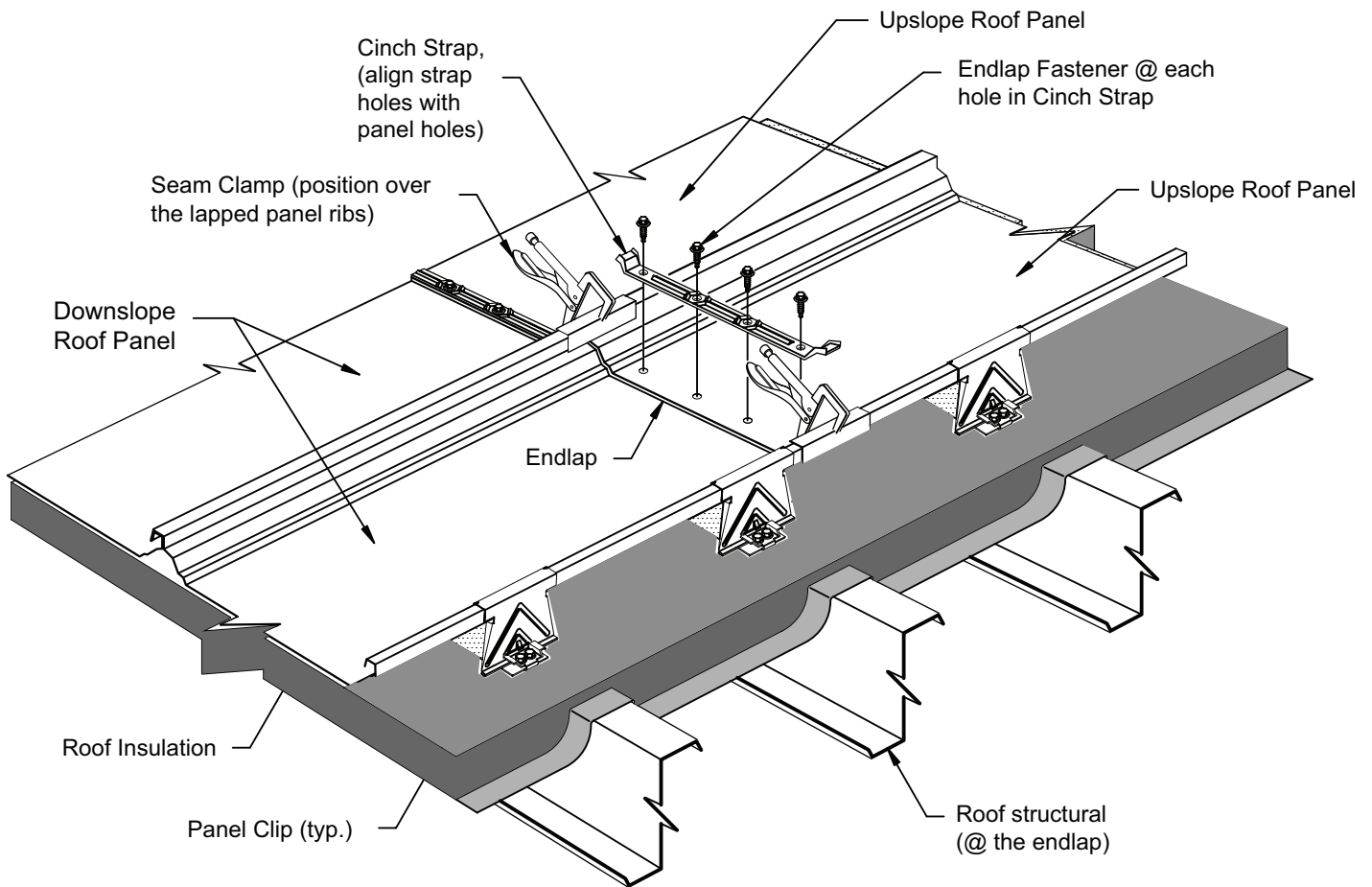

A cinch strap is not required on all roof applications. Refer to the erection drawings to determine if a cinch strap is required.

If a cinch strap is not required, use the following procedures but without placing the cinch strap. Fastener spacing is the same as required at the eave.

If a cinch strap is required, carefully remove the punches and position the cinch strap over the factory punched holes in the roof panel.

Use a punch to align the factory punched holes in the cinch strap, roof panels and back-up plate.

Install endlap fasteners in the holes at each end of the cinch strap. Next install fasteners in the remaining holes.

Check that the endlap fasteners penetrate through the center of the endlap sealant and are securely engaged into the back-up plate.

Remove seam clamps to complete installation

Specific endlap details are shown on the following page.

**9.3S ROOF PANEL INSTALLATION
OPTIONAL STAGGERED ENDLAP**

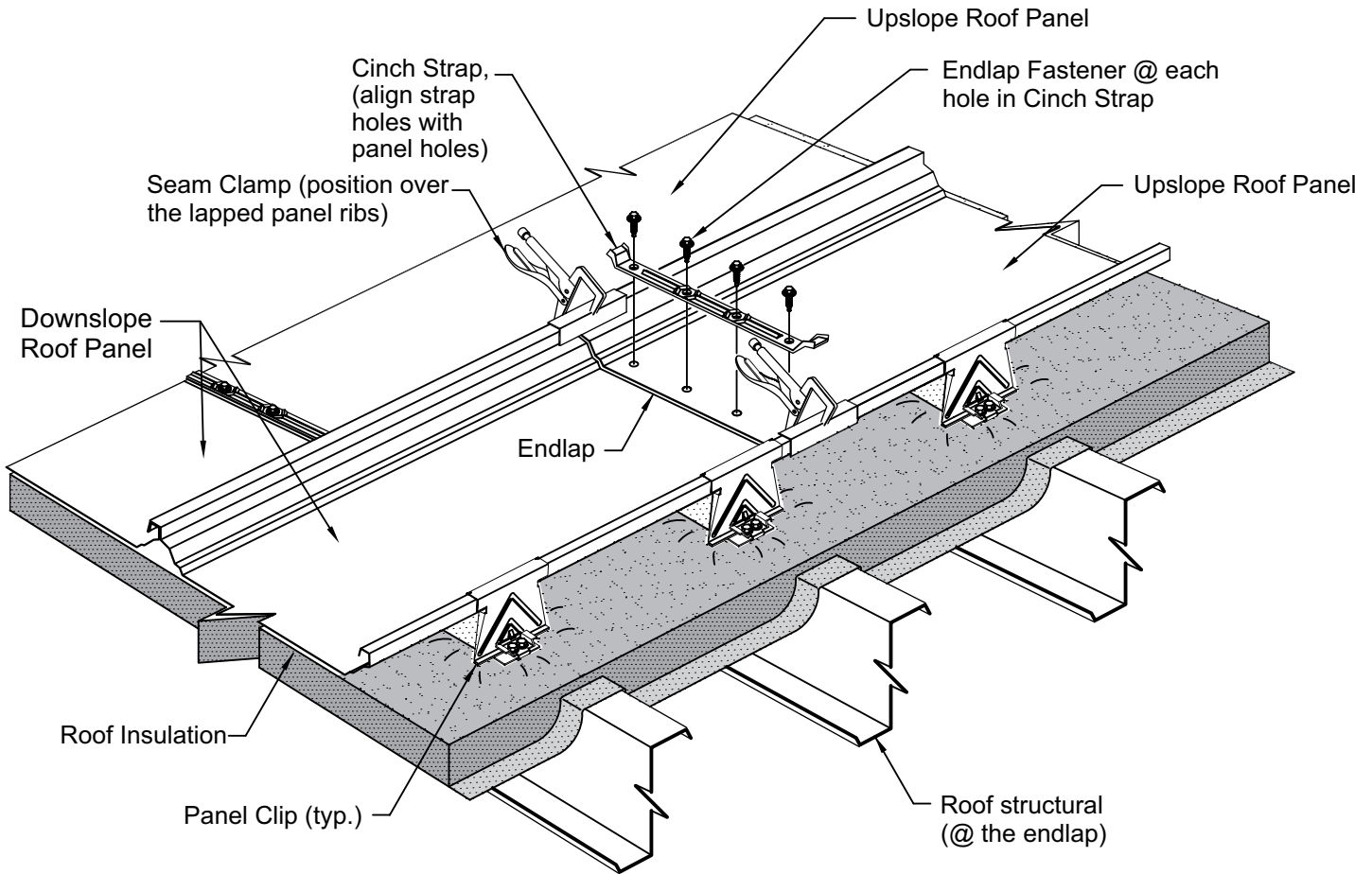

A cinch strap is not required on all roof applications. Refer to the erection drawings to determine if a cinch strap is required.

If a cinch strap is not required, use the following procedures but without placing the cinch strap. Fastener spacing is the same as required at the eave.

If a cinch strap is required, carefully remove the punches and position the cinch strap over the factory punched holes in the roof panel.

Use a punch to align the factory punched holes in the cinch strap, roof panels and back-up plate.

Install endlap fasteners in the holes at each end of the cinch strap. Next install fasteners in the remaining holes.

Check that the endlap fasteners penetrate thru the center of the endlap sealant and are securely engaged into the back-up plate.

Remove seam clamps to complete installation

Specific endlap details are shown on the following page.



9.3 ROOF PANEL INSTALLATION

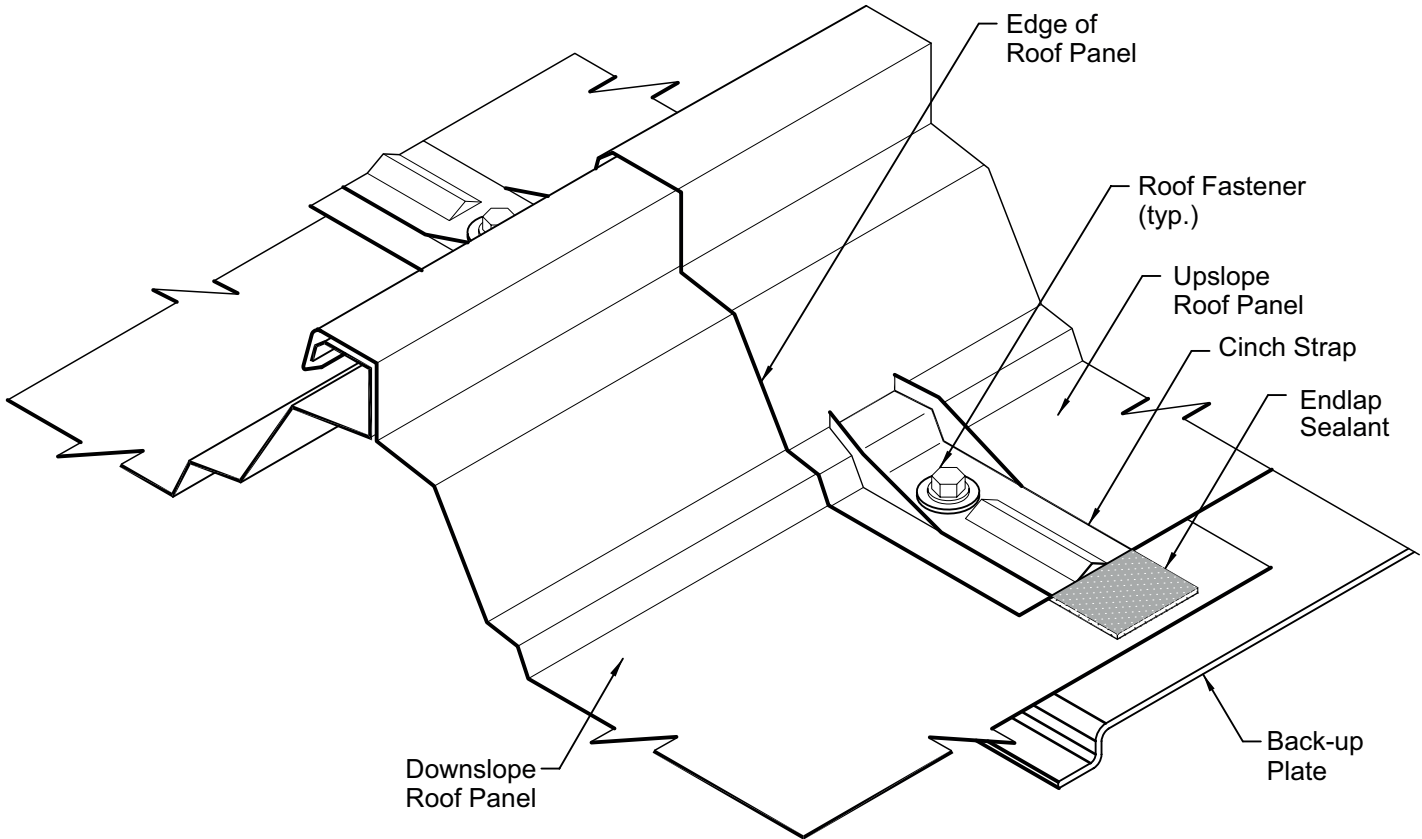

Check that the endlap is correctly assembled as shown.

Check that there are no unsealed voids between the lapped panels, especially at the critical corner areas.

9.3S ROOF PANEL INSTALLATION
OPTIONAL STAGGERED ENDLAP

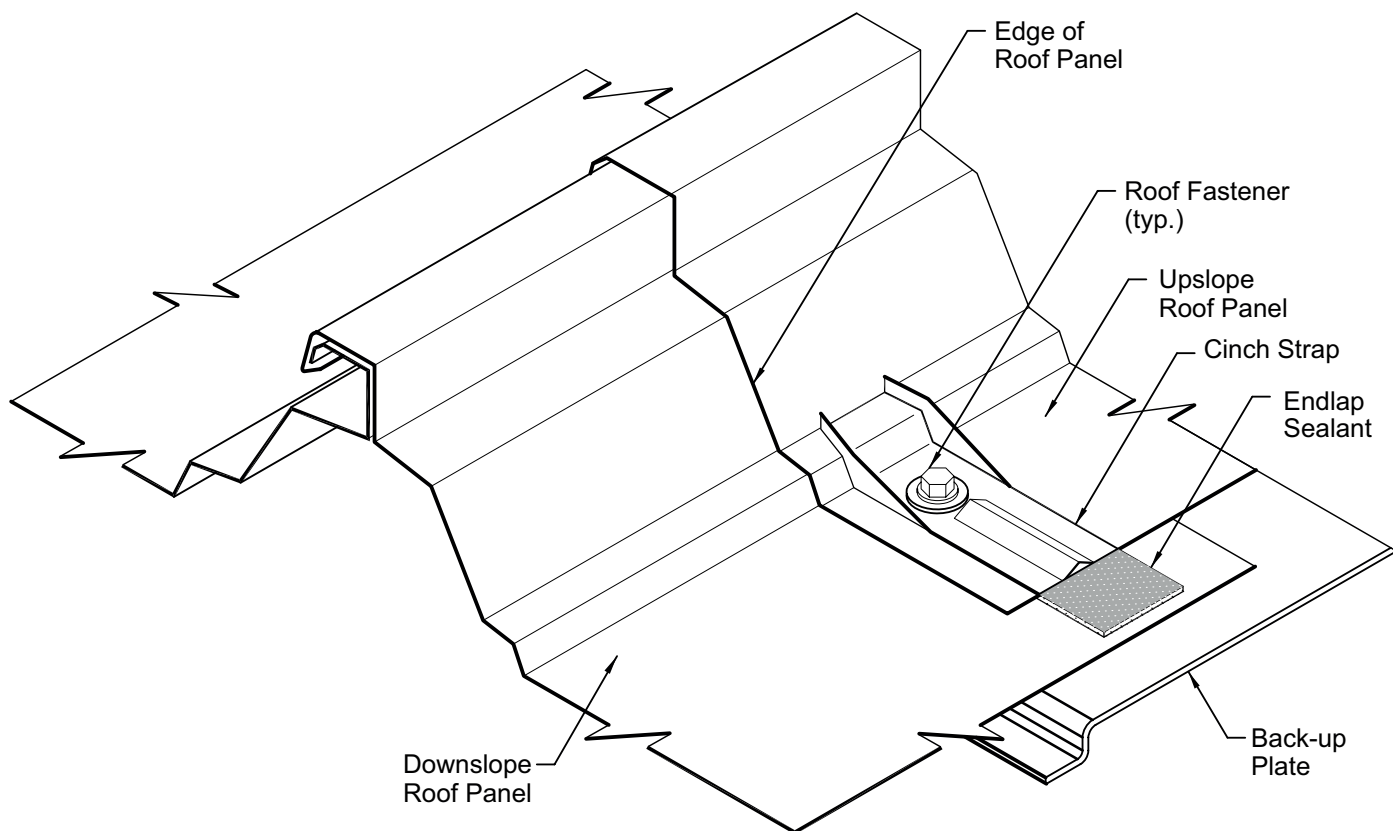

Check that the endlap is correctly assembled as shown.

Check that there are no unsealed voids between the lapped panels, especially at the critical corner areas.

9.3 ROOF PANEL INSTALLATION

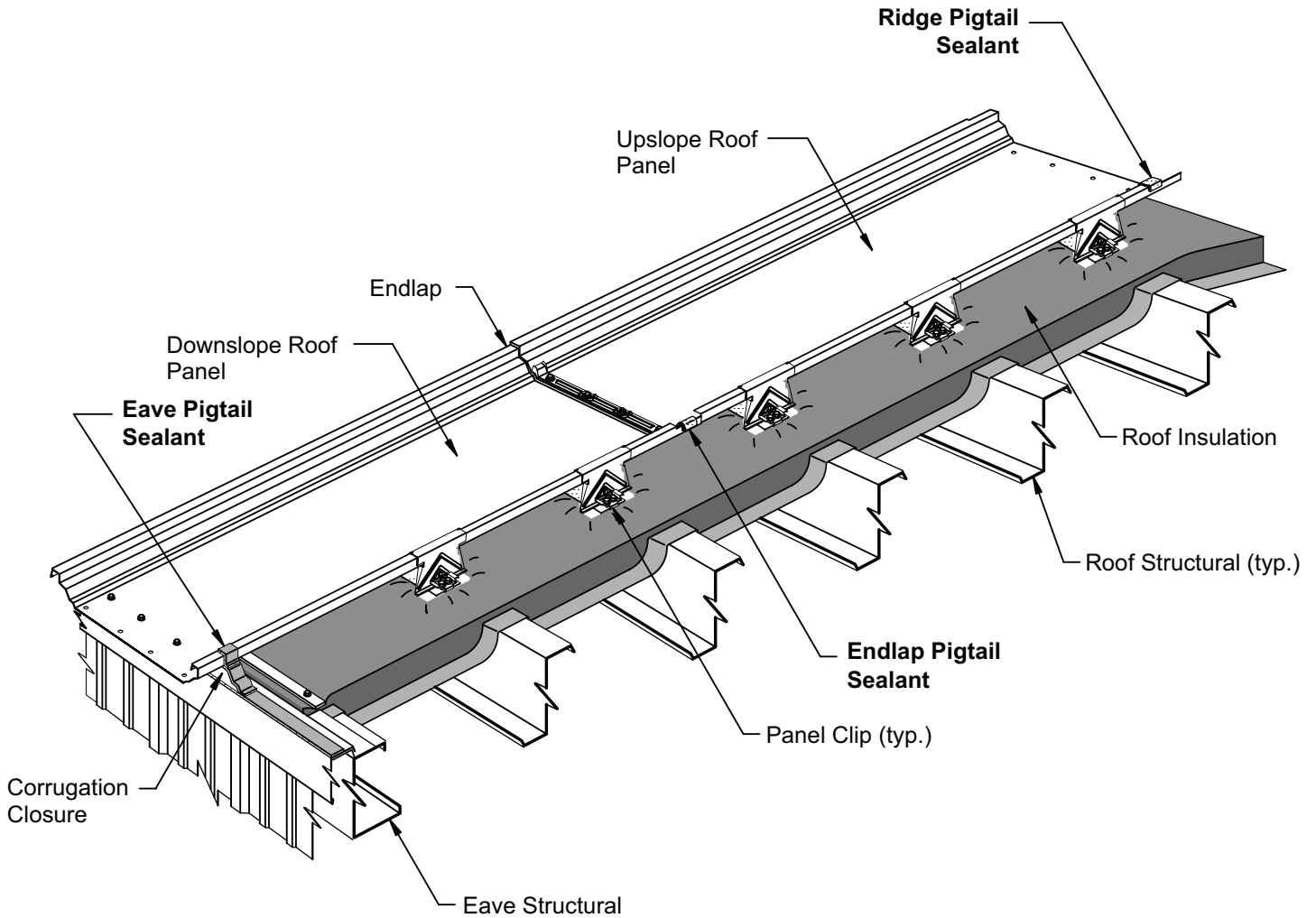

The pigtail sealants must be correctly installed before the next roof panel run can be installed.

The pigtail sealants are pieces of endlap sealant cut to the required length.

Install the eave, endlap and ridge pigtail sealants on the leading edge of the roof panel as shown.

Refer to the next pages for specific pigtail sealant details.



9.3 ROOF PANEL INSTALLATION

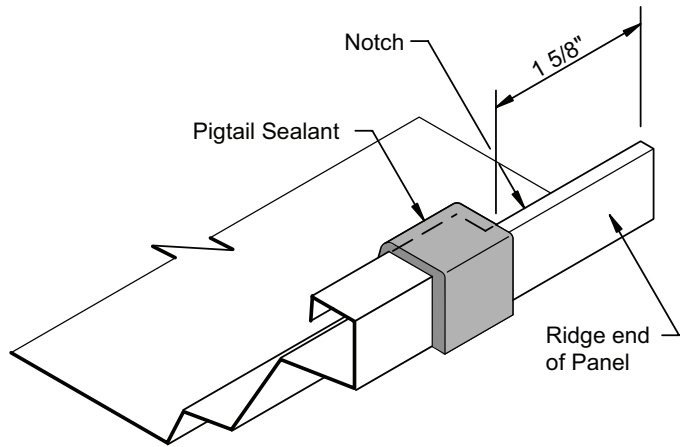
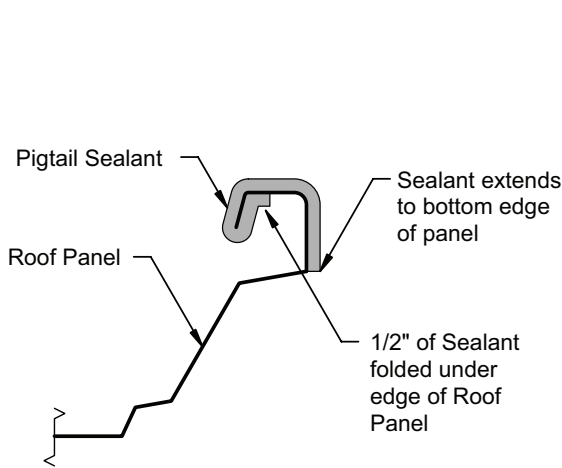

RIDGE PIGTAIL SEALANT DETAIL

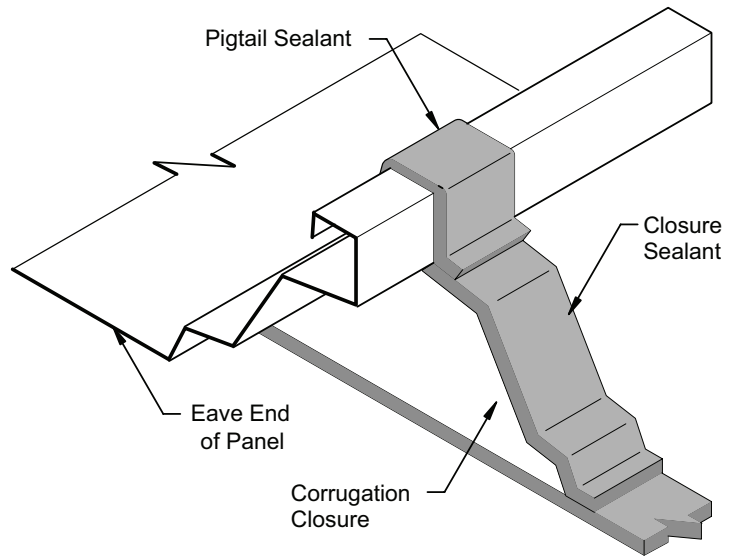
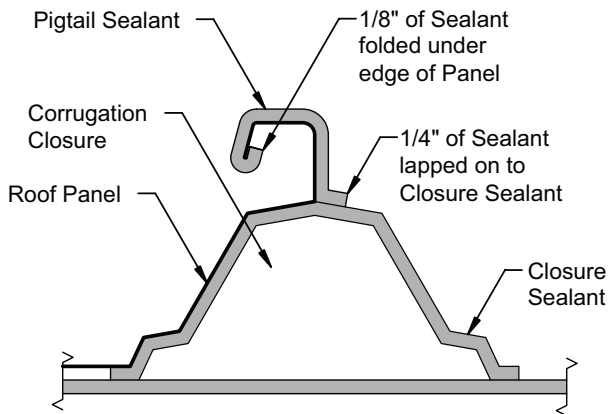

EAVE PIGTAIL SEALANT DETAIL

Cut the pigtail sealants to be fitted around the roof panel's seam as shown. Use box knife or scissors to cut. **Do not tear or pull.**

At the eave, lap 1/4" of the pigtail sealant onto the corrugation closure's sealant. Cut the other end of the pigtail sealant so 1/8" can be folded under the edge of the roof panel. Strip length = 2 1/2" long.

At the ridge, position the pigtail sealant so its edge is 1 5/8" from the end of the roof panel. The sealant must lap over the edge of the roof panel's notch.

Fold 1/2" of the ridge pigtail sealant under the edge of the roof panel. Cut the other end of the sealant so it sets flush with the bottom edge of the roof panel's seam. Strip length = 2 1/2" long.

Excess sealant in the seams will cause difficult roof panel assembly. Remove any excess sealant. Cut, do not tear.

After the pigtail sealant is correctly placed, uniformly press the sealant against the panel's surface to assure adhesion.



9.3 ROOF PANEL INSTALLATION

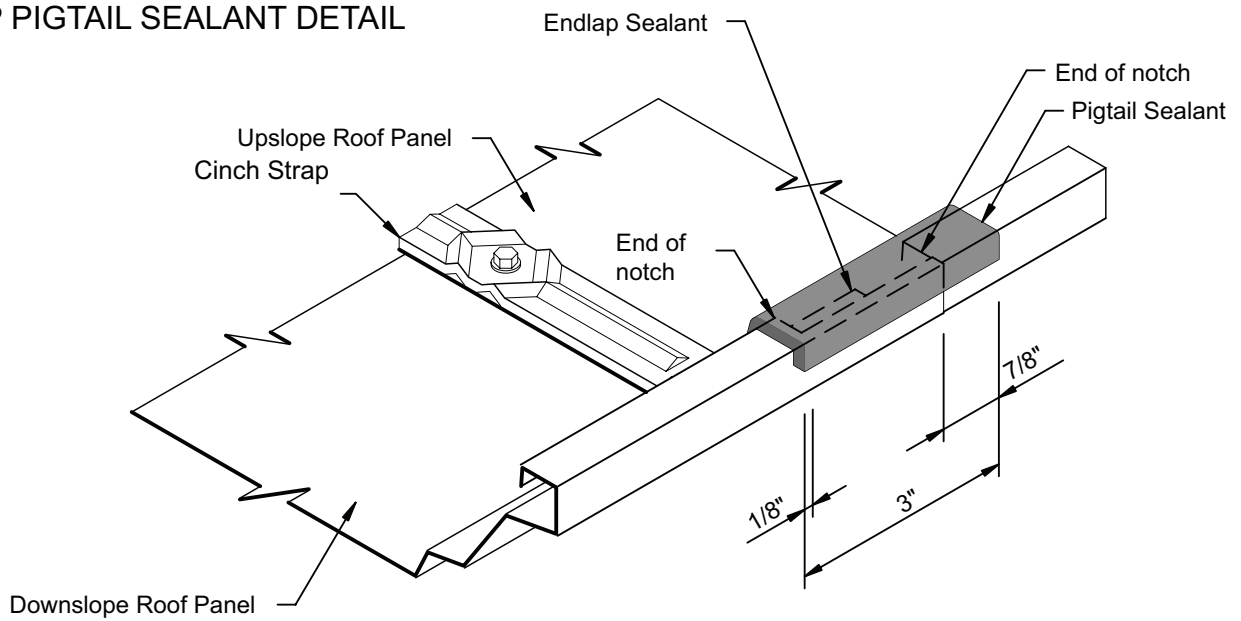
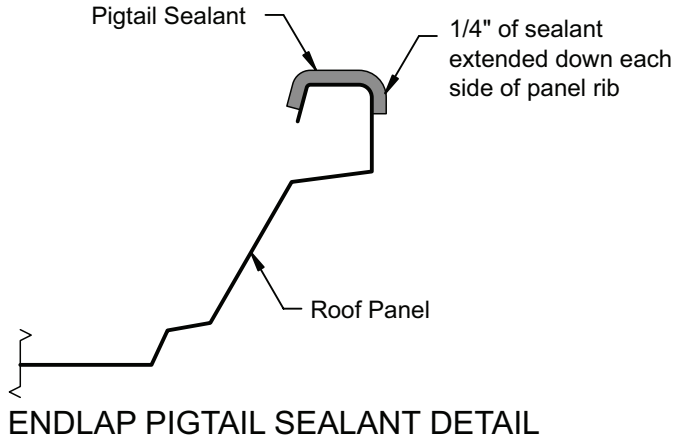

Cut the pigtail sealant to a 3" length and fit around the roof panel's seam as shown.

Position the pigtail sealant to lap 1/8" over the downslope end of the roof panel's notch.

Center the sealant over the roof panel's seam. Fold the edges of the sealant down over the sides of the seam.

Excess sealant in the seams will cause difficult roof panel assembly. **Remove any excess sealant. Cut, do not tear.**

After the pigtail sealant is correctly placed, uniformly press the sealant against the panel's surface to assure adhesion.

9.3 ROOF PANEL INSTALLATION

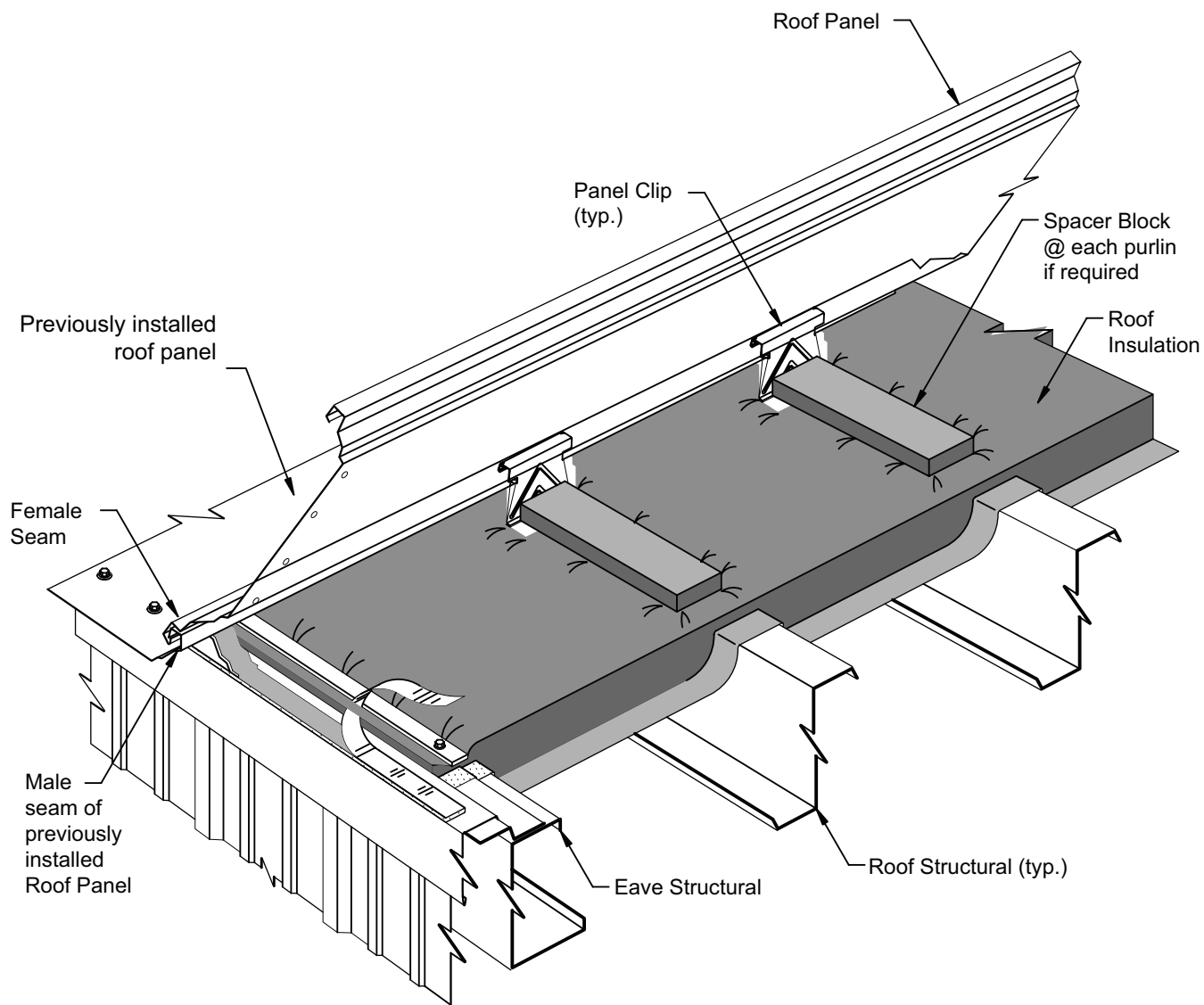

Repeat previous steps of first panel run and remove the protective paper from the eave sealant. Remove only enough of the protective paper to allow installation of the next roof panel.

If required, place the insulation spacer blocks on top of the insulation directly over the roof structural.

Position the trailing edge of the roof panel over the leading edge of the previously installed roof panel and position the end of the roof panel 2" beyond the face of the eave trim.

Tilt the panel as shown so the female seam can be hooked over the male seam of the previous roof panel.

Specific roof panel sidelap assembly details are shown on the following page.



9.3 ROOF PANEL INSTALLATION

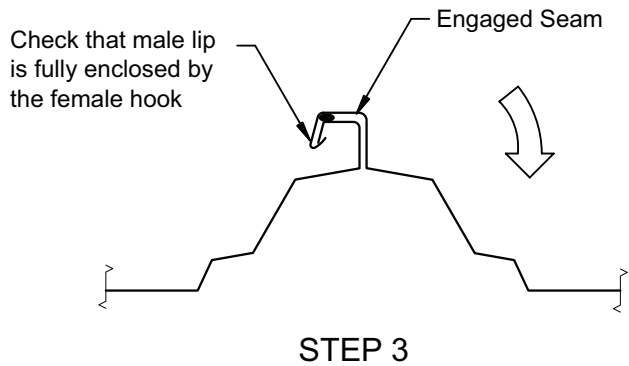
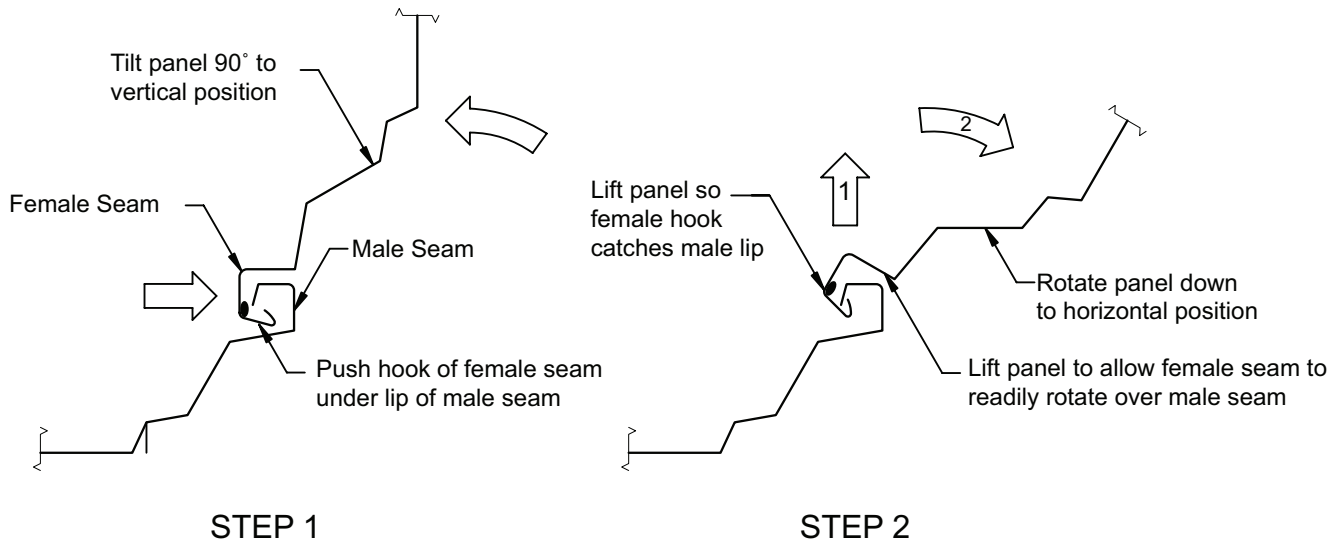

CAUTION
Excessive panel coverage width can prevent proper sidelap assembly. Check and correct panel coverage prior to installation of the next panel.

It is easier to hook the roof panel seams together if the roof panel is first tilted up to the vertical position.

While continuing to lift up on the roof panel, rotate the panel down to rest on the insulation or spacer blocks.

With the roof panel in the vertical position, align its female seam to slide under the male seam of the previous roof panel.

Be careful not to scrape off the seam sealant during the sidelap assembly.

With the female seam under the male seam, lift up the roof panel so the female seam's hook catches the lip of the male seam.

IMPORTANT: Check that the male and female are fully nested and the female hook has enclosed the male lip along the entire length of the roof panel. If not, the roof panel sidelap must be correctly reassembled before installing the next roof panel.

9.3 ROOF PANEL INSTALLATION

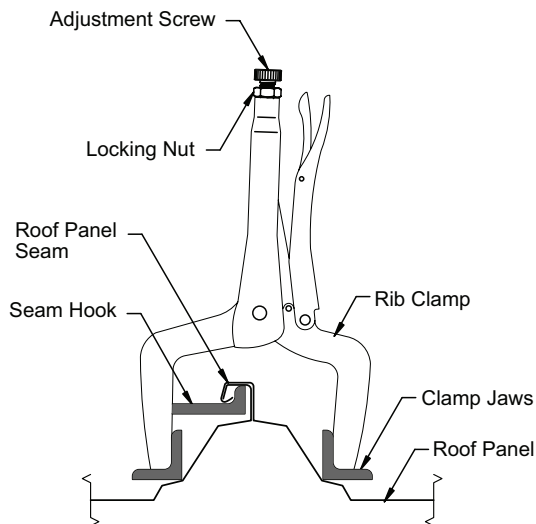

RIB CLAMP DETAIL

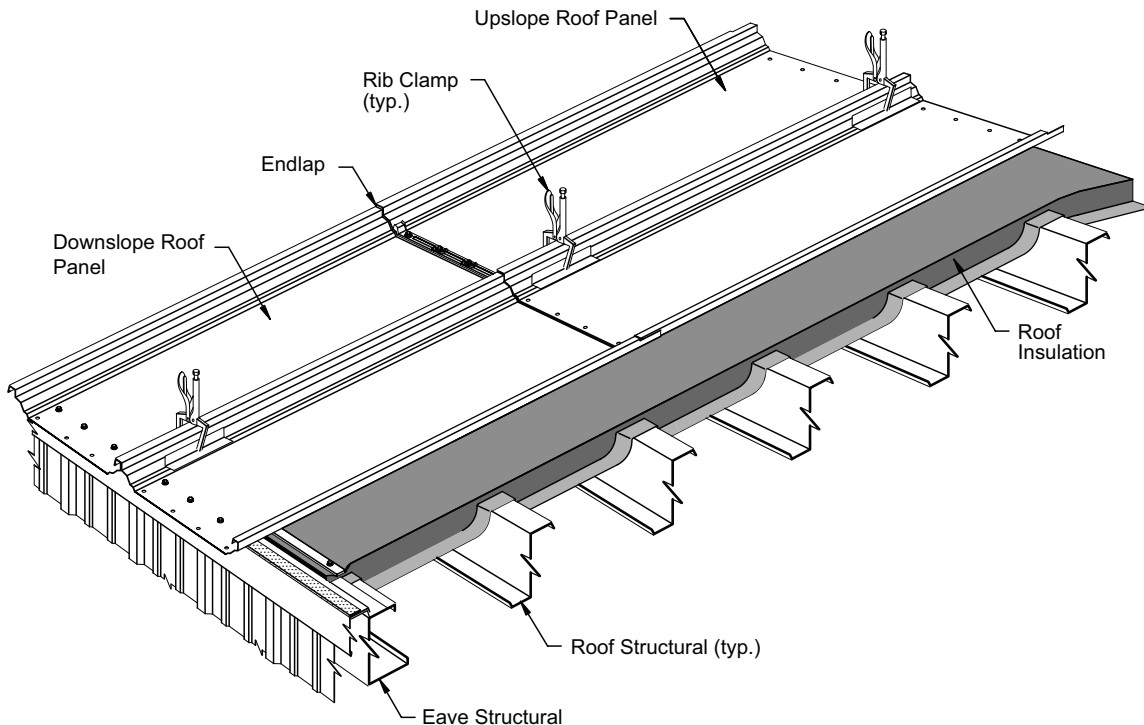

The most common coverage error is the spreading of the roof panels, especially at the panel ends. This can cause excess panel coverage along the eave, endlaps and ridge.

To correct excess roof panel coverage, use rib clamps to squeeze together the panel ribs as shown.

The rib clamps can be adjusted and locked so that they will squeeze the panel ribs to provide a consistent coverage width.

If excessive coverage has accumulated over several panel runs, do not try to correct all of the error at one time. Corrected roof panel coverage must not be greater than 1/8" per panel. Correct accumulated coverage error by making the correction over several panel runs.

Continue process until opposite ends of the structure are reached.

End dams should be installed at the ridge along with the panel.



9.3.22 ADJUST PANEL COVERAGE

9.3S ROOF PANEL INSTALLATION

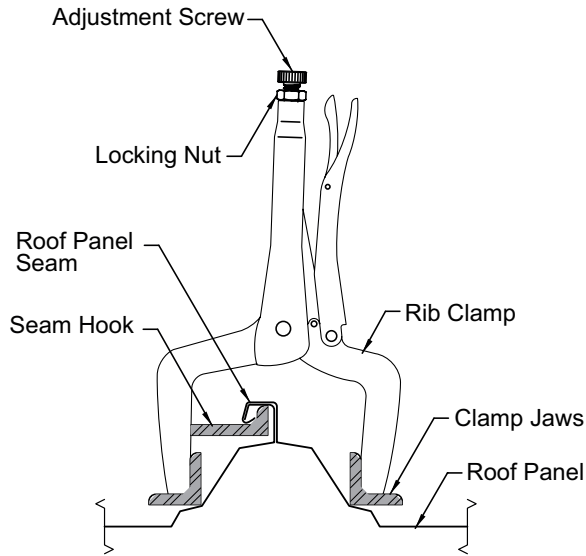

RIB CLAMP DETAIL

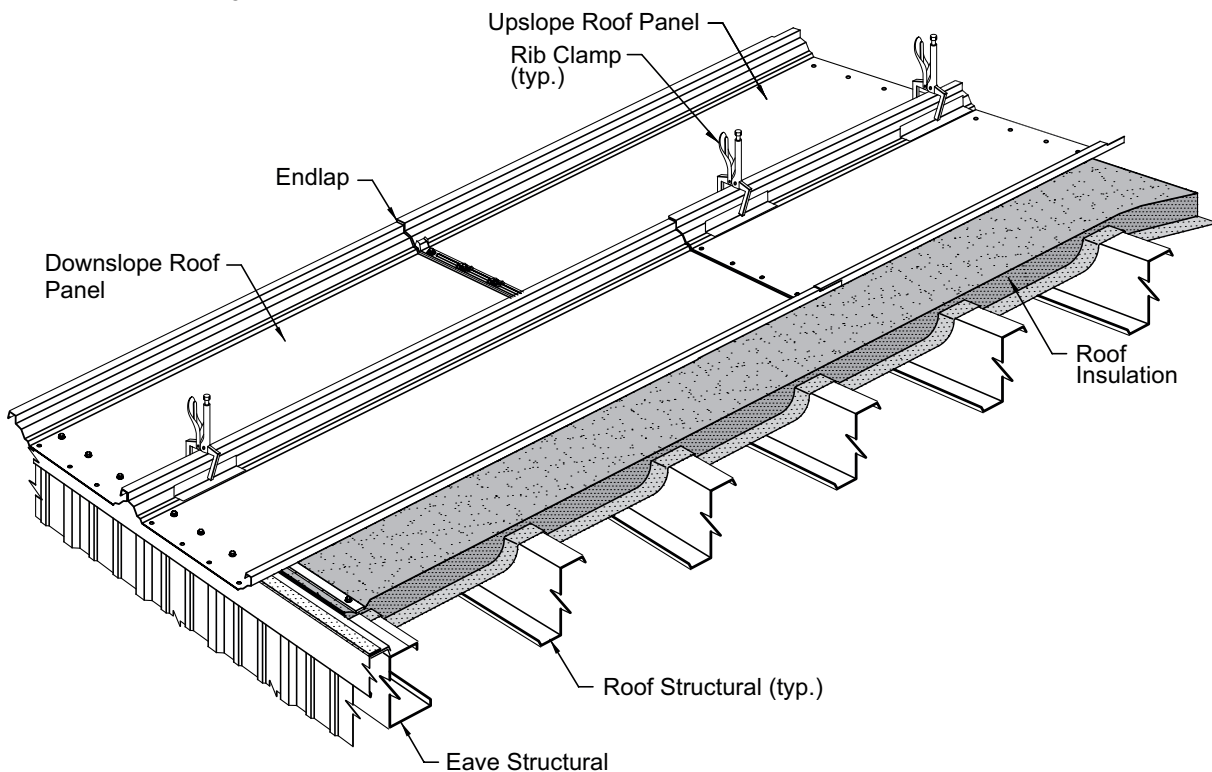

The most common coverage error is the spreading of the roof panels, especially at the panel ends. This can cause excess panel coverage along the eave, endlaps and ridge.

To correct excess roof panel coverage, use rib clamps to squeeze together the panel ribs as shown.

The rib clamps can be adjusted and locked so that they will squeeze the panel ribs to provide a consistent coverage width.

If excessive coverage has accumulated over several panel runs, do not try to correct all of the error at one time. Corrected roof panel coverage must not be greater than 1/8" per panel. Correct accumulated coverage error by making the correction over several panel runs.

Continue process until opposite ends of the structure are reached.

End dams should be installed at the ridge along with the panel.

9.3 ROOF PANEL INSTALLATION

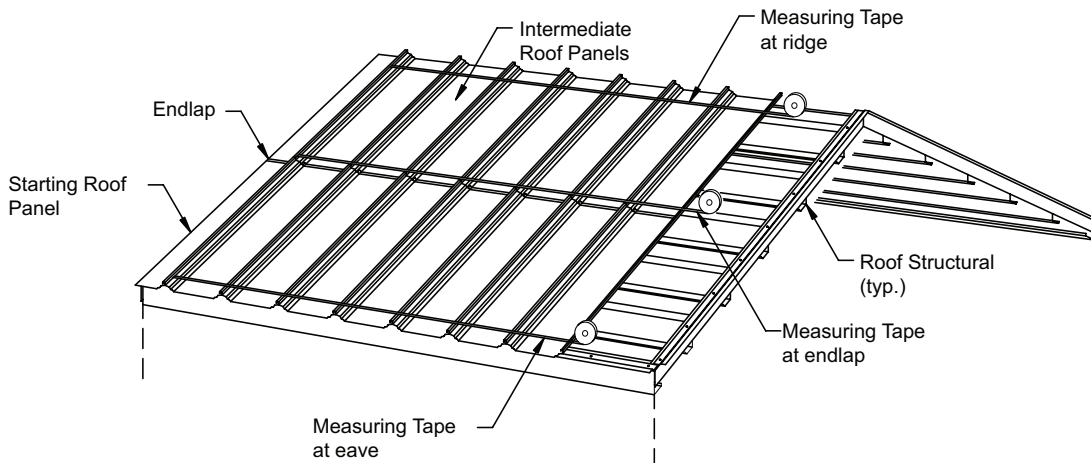

CHECKING PANEL COVERAGE

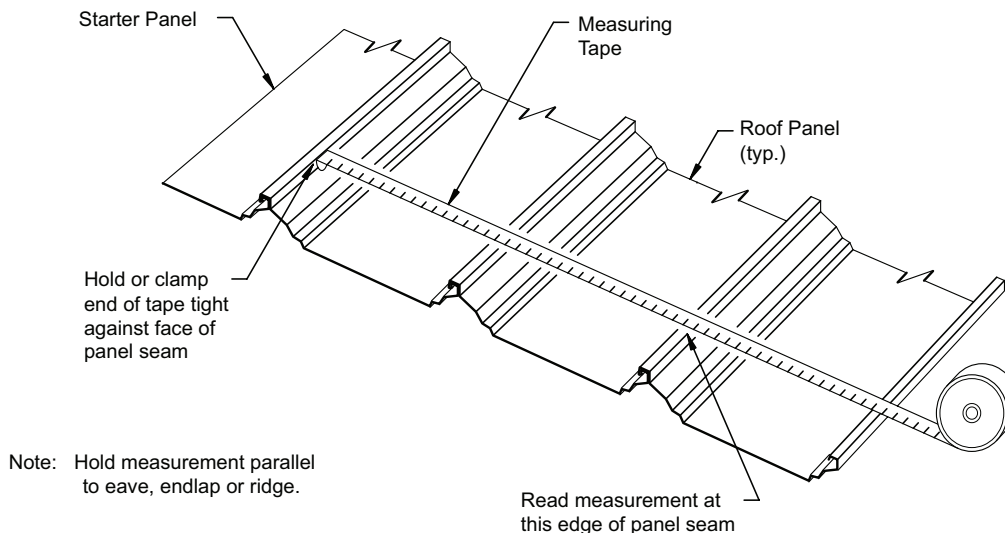

PANEL COVERAGE MEASUREMENT

Caution: To assure proper fit-up of the sidelap assembly, proper seaming, proper fit-up of closures, flashing, curbs, etc., it is important that each panel be held to within the 1/8" panel coverage tolerance and that overall coverage be checked frequently and any coverage error be corrected before it accumulates.

Coverage must be checked at the eave and ridge and at every endlap.

To avoid accumulation error, the coverage measurement should always be from the rake line or the starting roof panel's seam.

To avoid measurement error, the measuring tape must be free and taut and must be parallel to the eave line or ridge line.

Improper coverage will cause difficulty in seaming.



9.3S ROOF PANEL INSTALLATION OPTIONAL STAGGERED ENDLAP

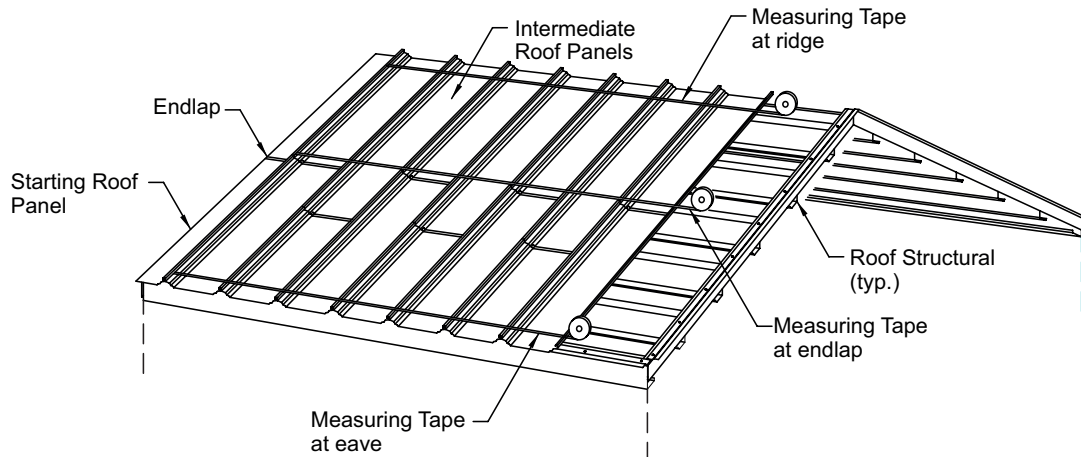

CHECKING PANEL COVERAGE

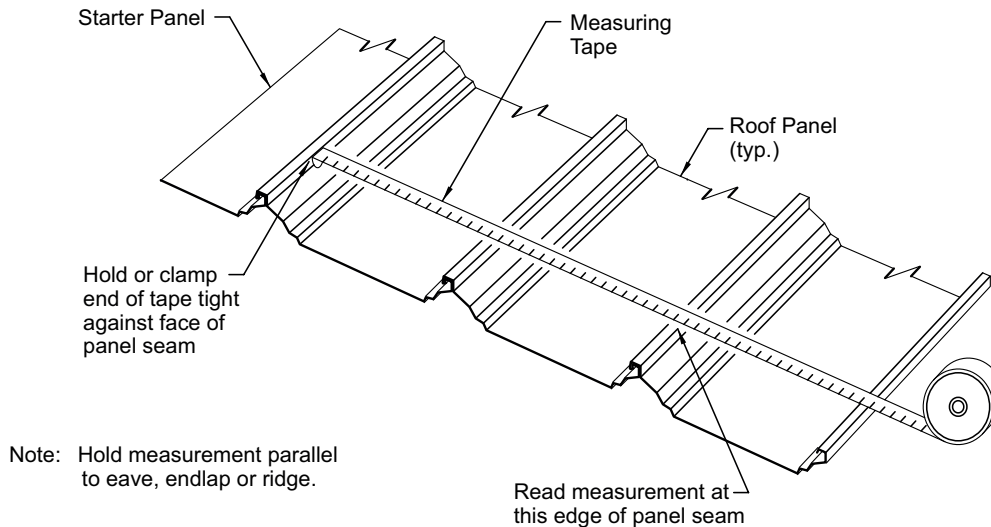

PANEL COVERAGE MEASUREMENT

Caution: To assure proper fit-up of the sidelap assembly, proper seaming, proper fit-up of closures, flashing, curbs, etc., it is important that each panel be held to within the 1/8" panel coverage tolerance and that overall coverage be checked frequently and any coverage error be corrected before it accumulates.

Coverage must be checked at the eave and ridge and at every endlap.

To avoid accumulation error, the coverage measurement should always be from the rake line or the starting roof panel's seam.

To avoid measurement error, the measuring tape must be free and taut and must be parallel to the eave line or ridge line.

Improper coverage will cause difficulty in seaming.

9.4 END DAM INSTALLATION

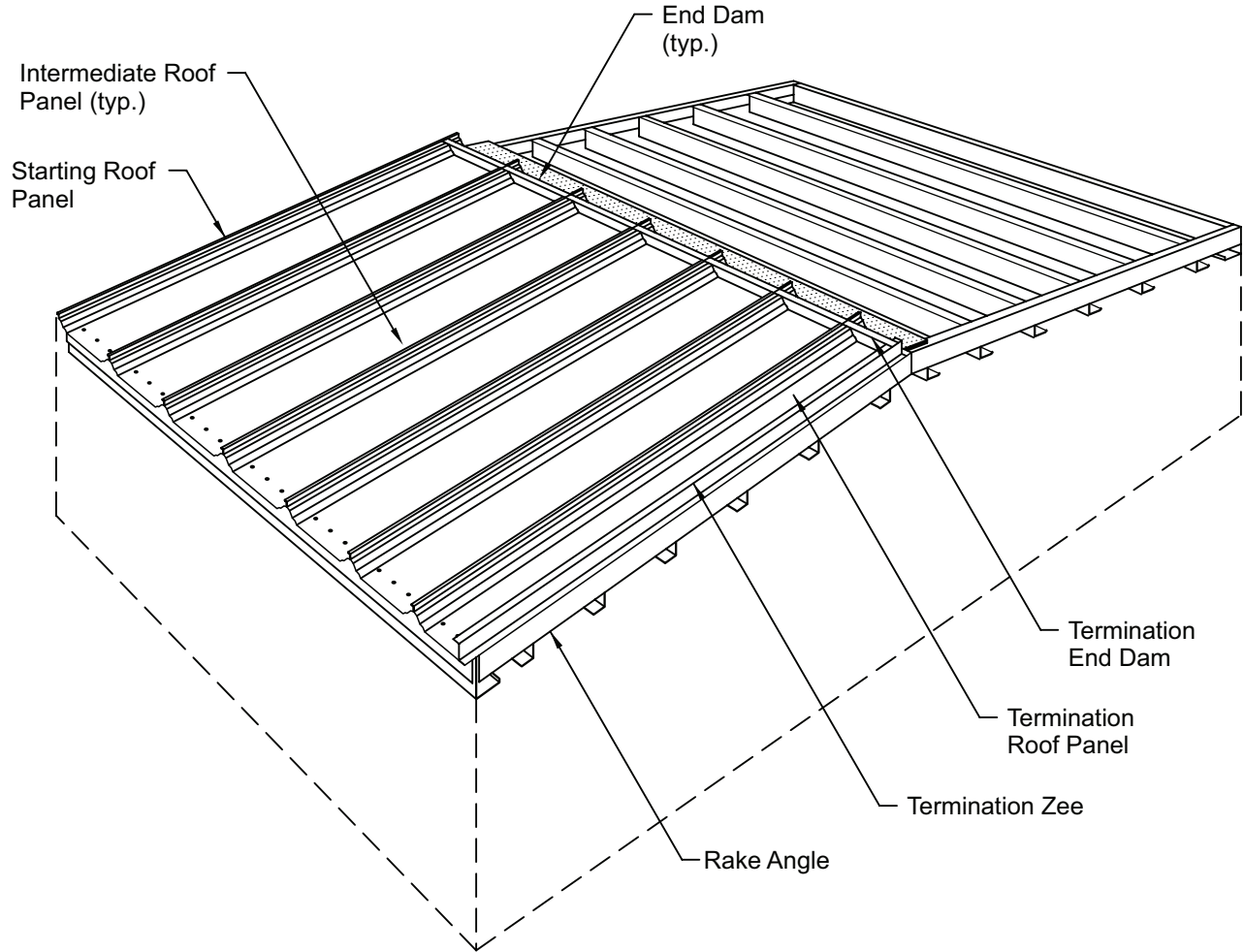

Metal end dams are used to close the ends of the roof panels at the ridge, high eave and high eave transition conditions.

The details in this section will show roof panel preparation requirements and installation of the end dams.

9.4 END DAM INSTALLATION

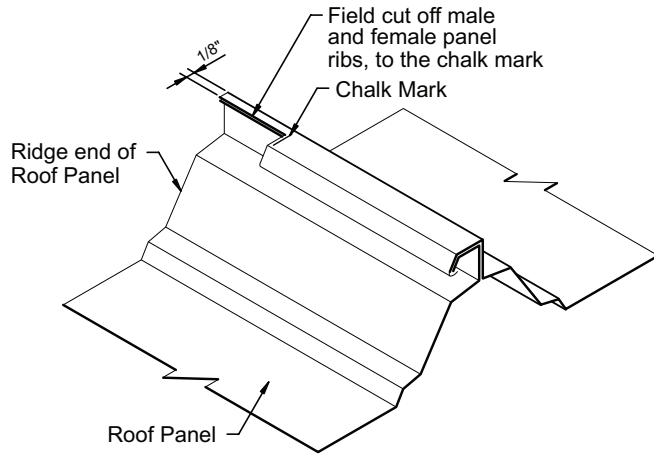

NOTCH FOR RIDGE CLOSURE

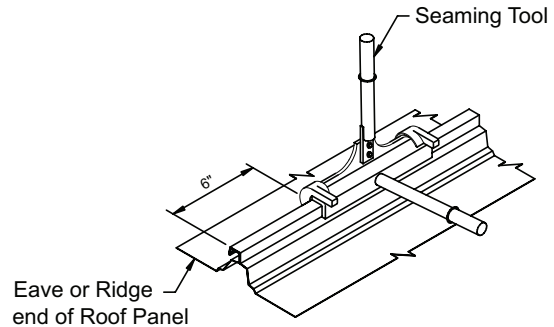

STEP 1

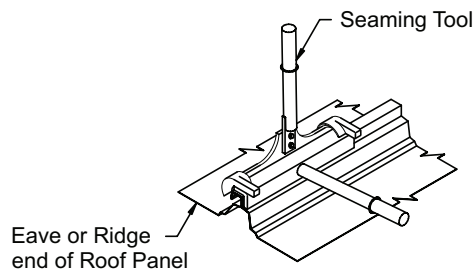

STEP 2

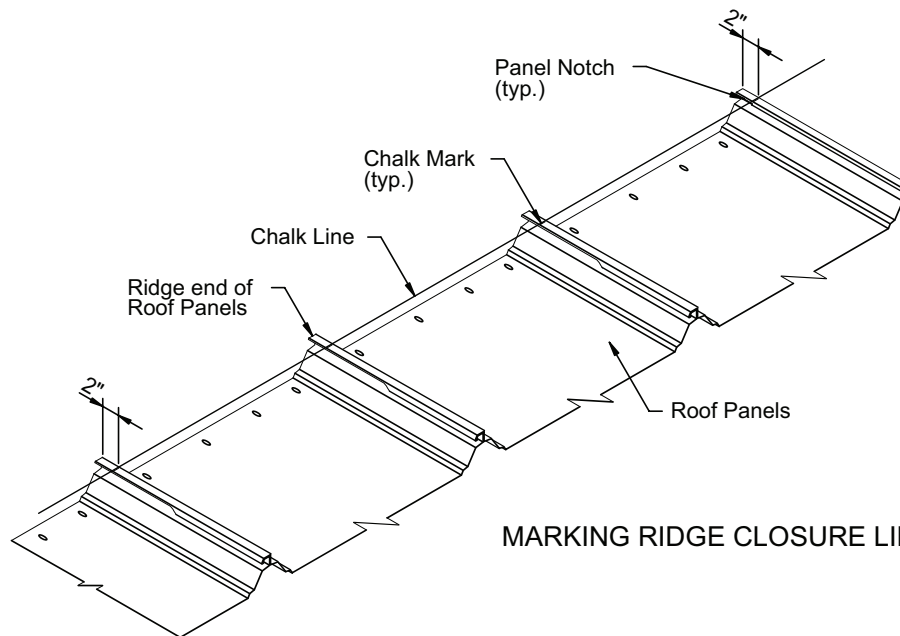

MARKING RIDGE CLOSURE LINE

The end dams should be installed before roof panel runs are completed. Installation of the end dams helps maintain the correct roof panel coverage at the ridge. If the end dams are installed after the roof panels are in place, roof panel coverage error may prevent proper installation of the end dams.

to establish a straight notch line. Position the chalk line so no notch extends below the line.

Using the end of the factory notch (or chalk marks) as a guide, field cut the additional notching in both male and female portions of the seam as shown.

Check the alignment of the roof notches along the ridge. If the notches are staggered more than 1/4", use a chalk line

Hand seam 16" of uphill panel end before installing tape sealant and end dam to accommodate motor seamer - Refer to seaming guide for specific instructions.

9.4 END DAM INSTALLATION

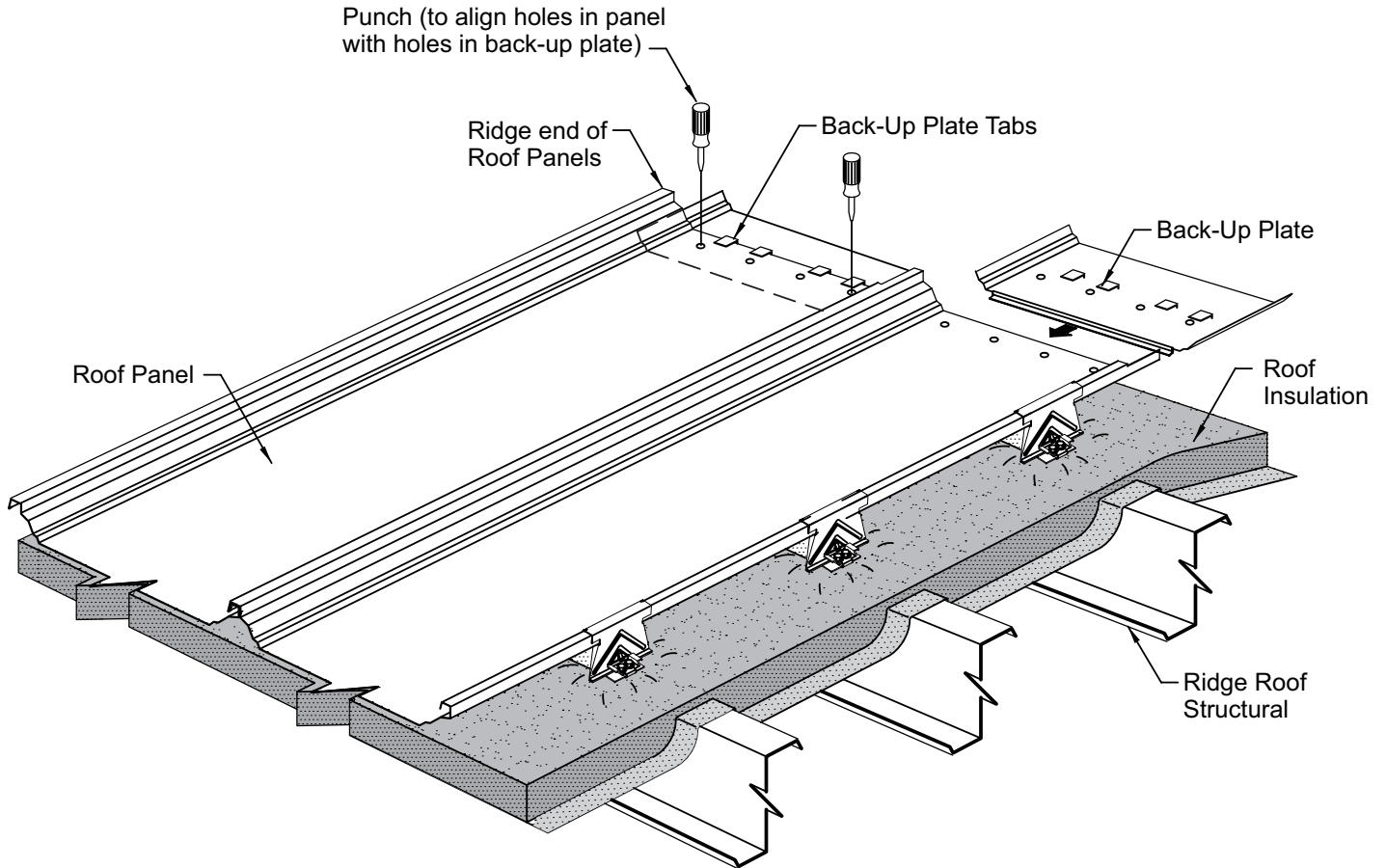

Slide the back-up plate under the roof panel as shown.

The back-up plate's tabs must hook over the end of the roof panel.

Use punches to align the holes in the back-up plate with the factory punched holes in the roof panel.

9.4 END DAM INSTALLATION

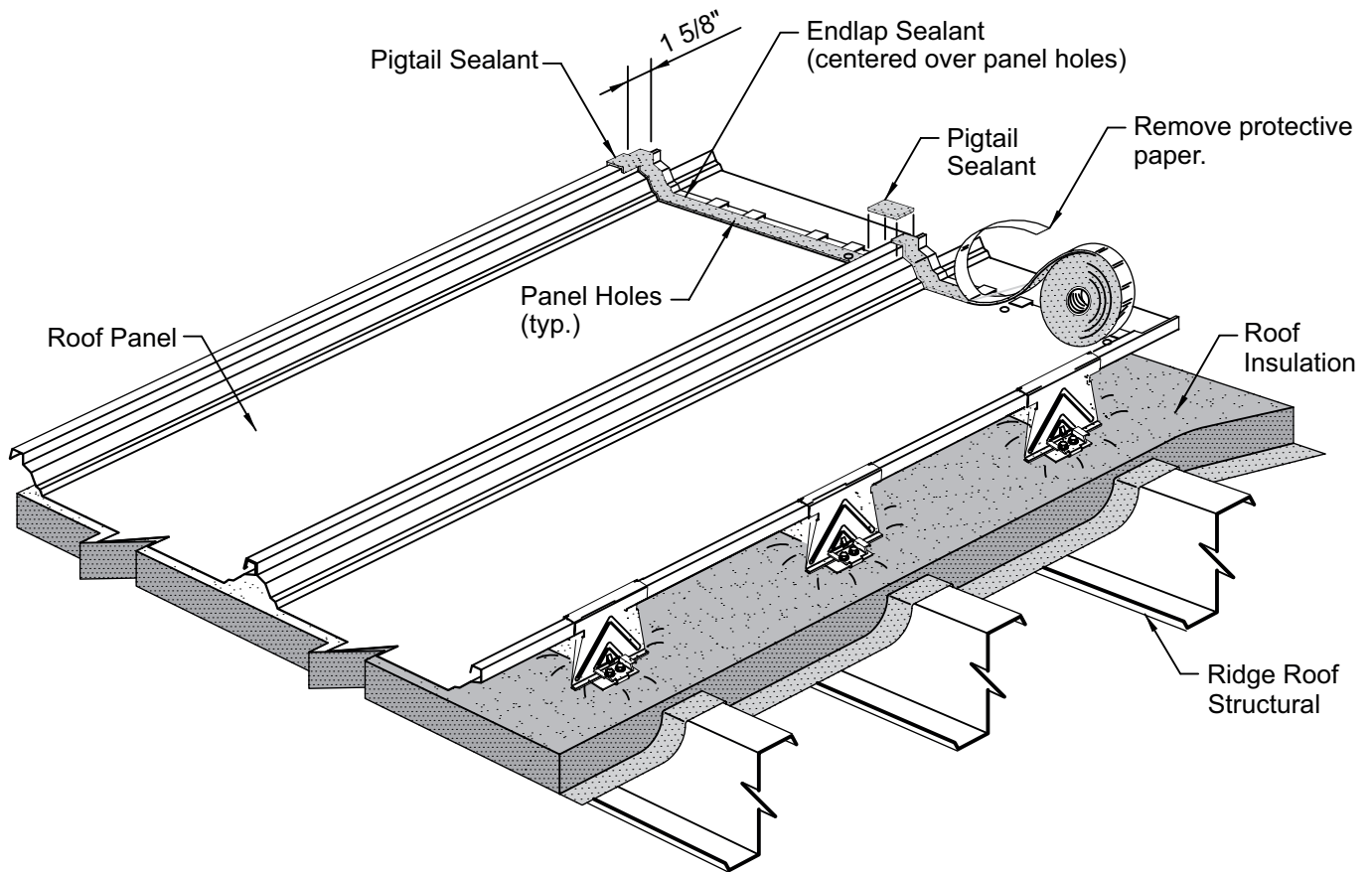

Before installing the endlap sealant, the roof panel's surface must be wiped clean and dry.

Install a continuous strip of endlap sealant along the end of the roof panel as shown.

Position the sealant so that its downslope edge is uniformly 1 5/8" from the end of the panel. The sealant must be centered over the roof panel's factory punched holes.

Be sure to check that the sealant fully contacts the roof panel's surface and that it is completely fitted into the panel corners and around the seams

Cut a 2 1/2" strip of endlap sealant and install as the pigtail sealant as shown.

Specific endlap sealant details are shown on the following page.

9.4 END DAM INSTALLATION

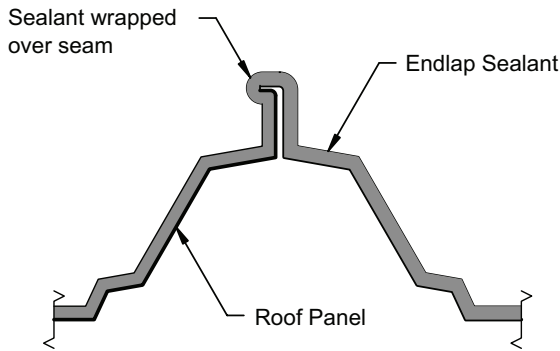

ENDLAP SEALANT @ RIDGE

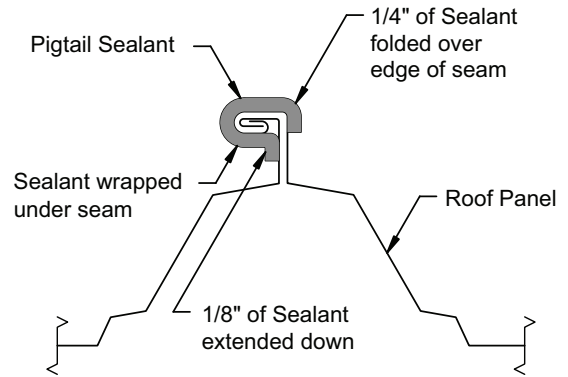

PIGTAIL SEALANT @ RIDGE

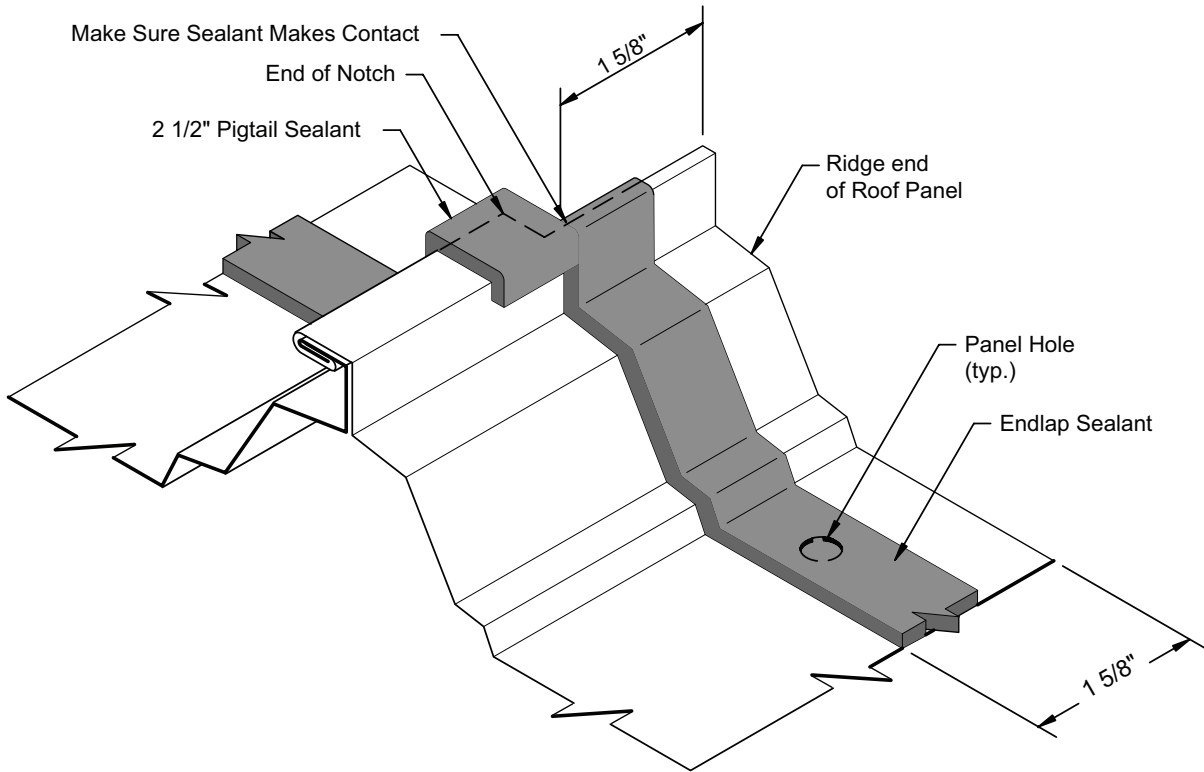

The correct installation of the ridge sealant is critical to the weather resistance of the roof system.

sealant against the roof panel's surface to assure adhesion. Do not use excess pressure, which can thin the sealant.

Be sure to verify that the sealant is installed as shown above before installing end dams.

After the sealant is correctly positioned, uniformly press the

9.4 END DAM INSTALLATION

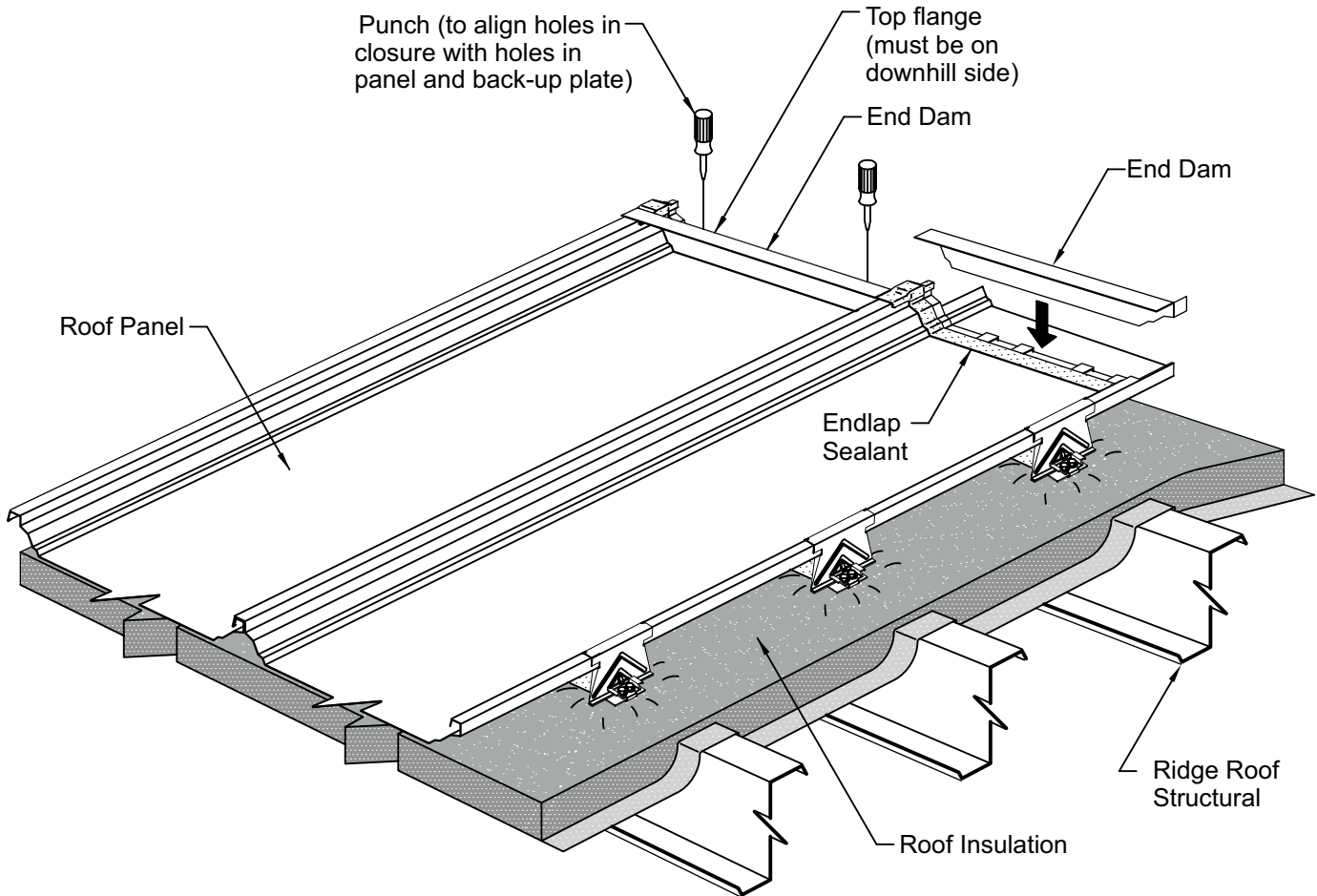

Wipe dry and clean the underside surface of the end dam flanges.

Remove the protective paper from the installed ridge sealant.

Position the end dam so its bottom flange is turned up-slope and its top flange is downslope.

Position the end dam's bottom flange directly over the ridge sealant and use punches to align the holes in the end dam with the factory punched holes in the roof panel and back-up plate.

Be careful not to displace or damage the sealant while installing the end dam and punches.

9.4 END DAM INSTALLATION

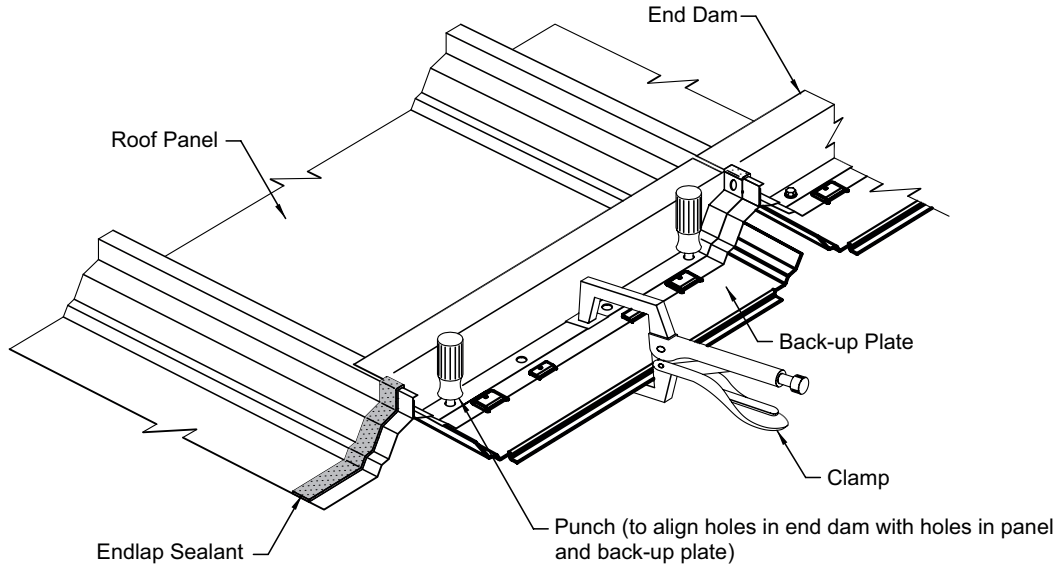

END DAM ALIGNMENT

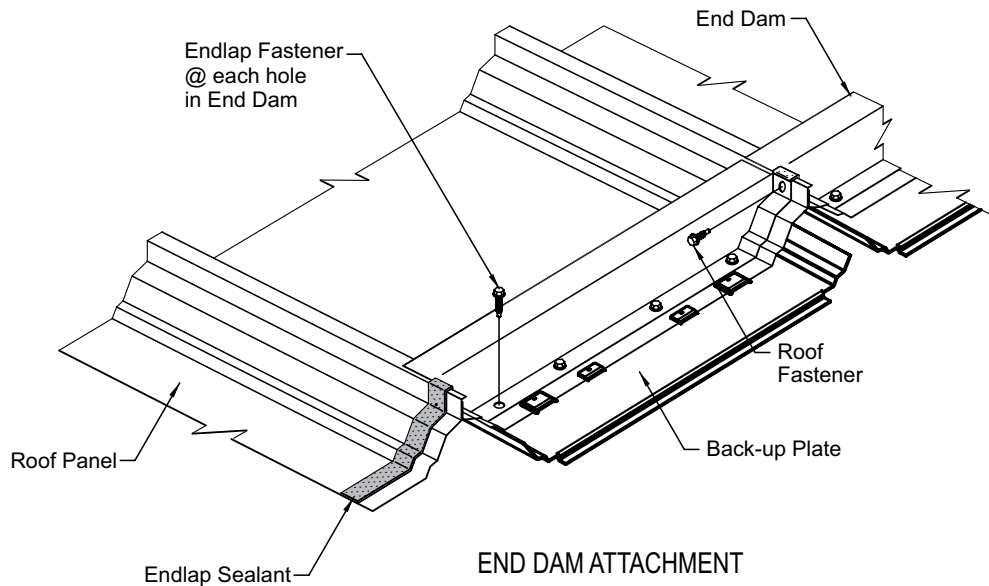

END DAM ATTACHMENT

While the matching holes are aligned by the punches, uniformly press the end dam into the ridge sealant to assure adhesion. Use a clamp to hold the assembly together while installing the fasteners.

Install endlap fasteners through the holes in the end dam's bottom flange.

Check that the fasteners penetrate through the center of the ridge sealant and are securely engaged into the back-up plate.

Check that the face of the end dam is perpendicular to the

roof panel and aligned with the previously installed end dams. If not, push the top of the end dam to the correct position.

Install a self-drilling fastener through the hole at the top of the end dam, through the roof panel seam and into the hole in the opposite end dam.

Important: Overtightening this fastener will squeeze the roof panel sidelap assembly together and may affect the roof panel's coverage width. Carefully tighten the fastener only as necessary to maintain the correct panel width.



9.4 END DAM INSTALLATION

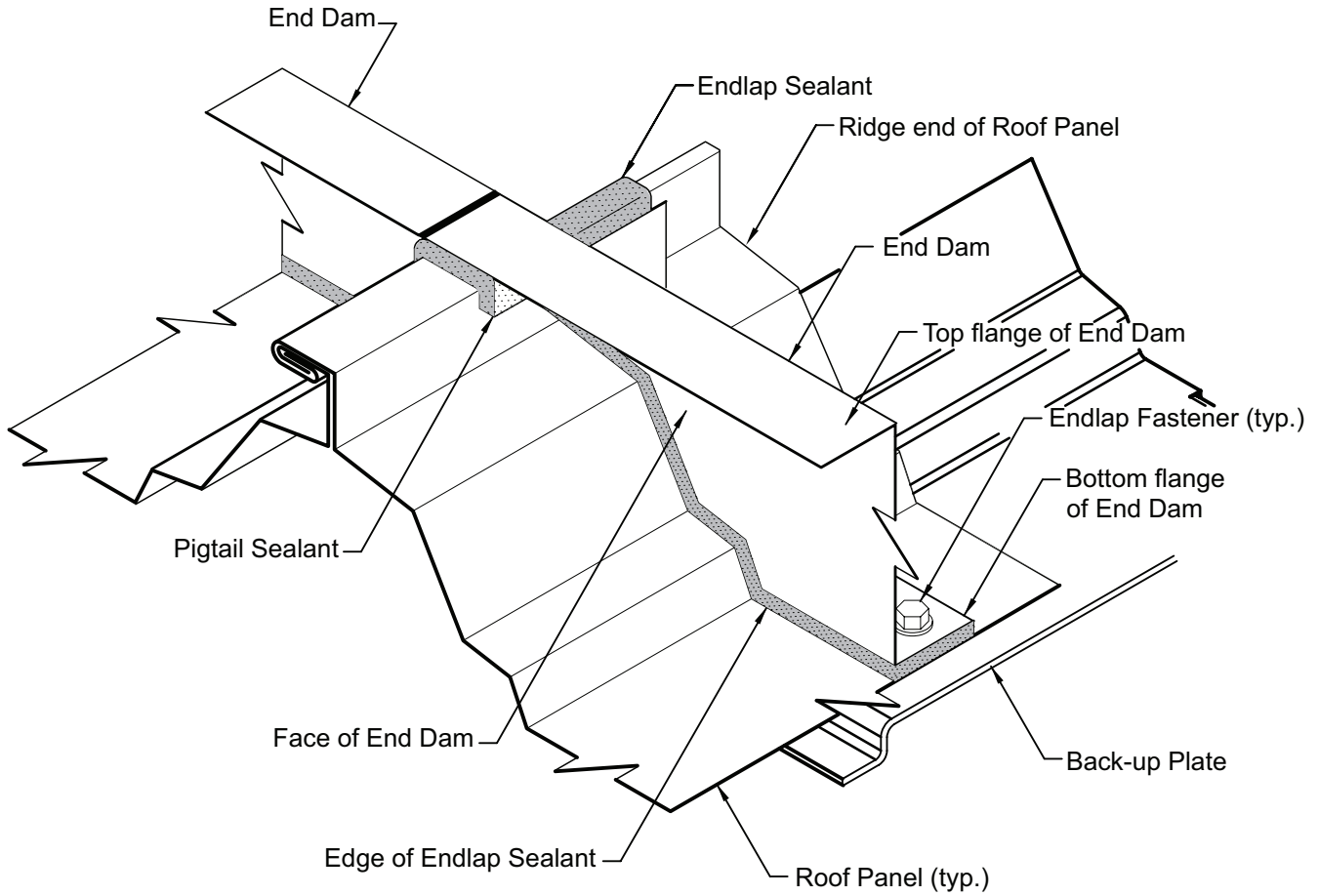

Verify that the end dam is correctly assembled as shown.
Check that there are no un-sealed voids between the roof

panel and the end dam, especially in the critical areas around the roof panel ribs and seams.

9.5 TERMINATION PANEL INSTALLATION

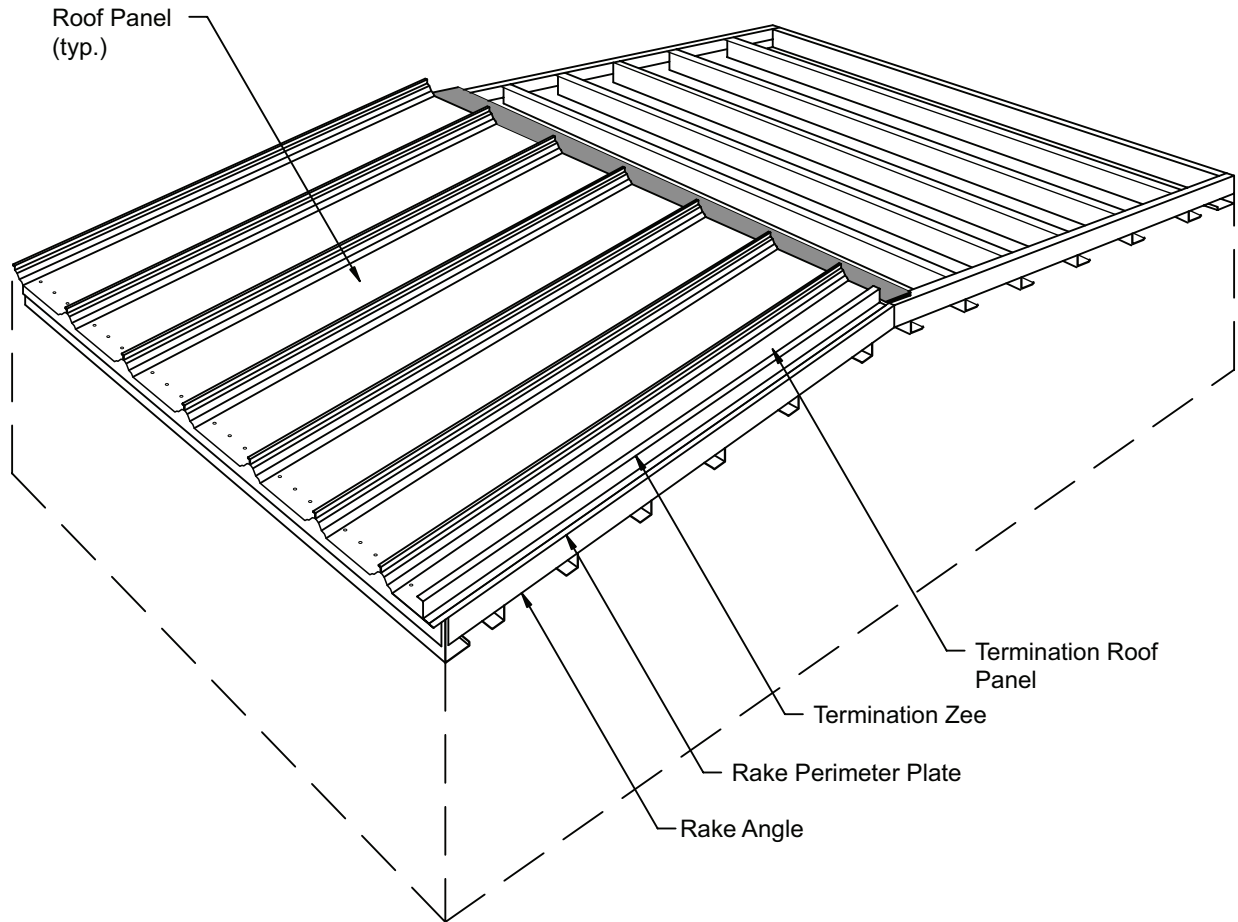

The details in this section show the installation of the termination roof panel and the termination zee.

finish rake. The installation of the termination panel at the starting rake is similar.

The details show the termination roof panel installed at the

9.5 TERMINATION PANEL INSTALLATION

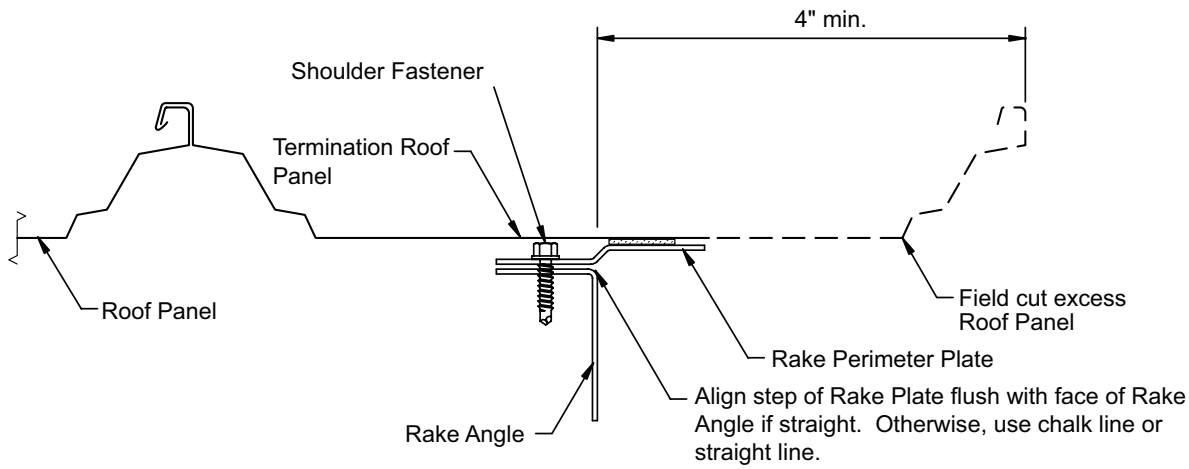

STANDARD RAKE PLATE POSITION

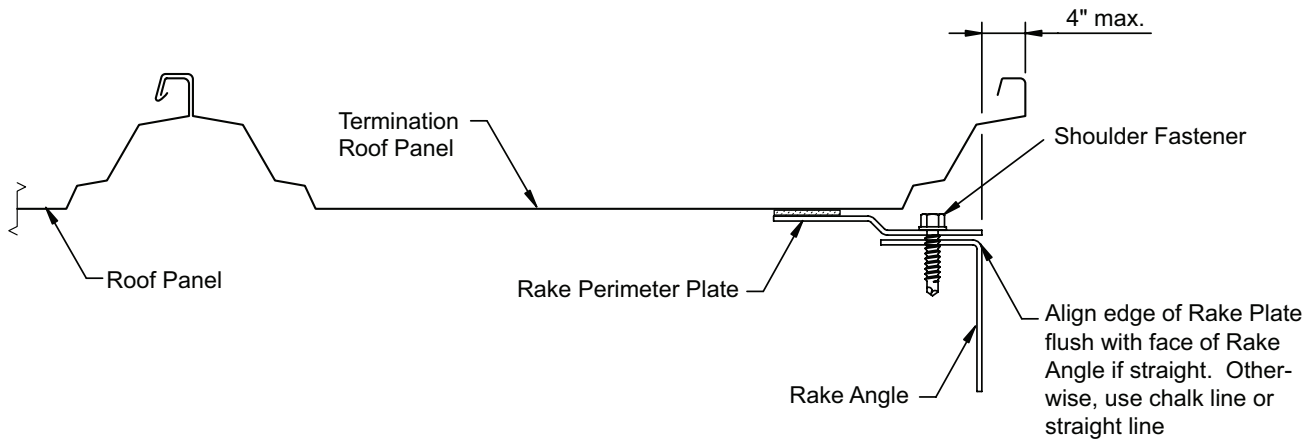

ALTERNATE RAKE PLATE POSITION

Refer to the erection drawings to determine which position to place the rake perimeter plate. The position of the rake perimeter plate will depend on the location of the termination roof panel as shown on the above illustrations.

If the leading edge of the panel extends 4" or more beyond the face of the rake angle, install the rake plate in the **standard** position.

If the leading edge of the panel extends less than 4" beyond the face of the rake angle, install the rake plate in the **alternate** position.

If the rake condition requires transition flashing, refer to the following page.

9.5 TERMINATION PANEL INSTALLATION

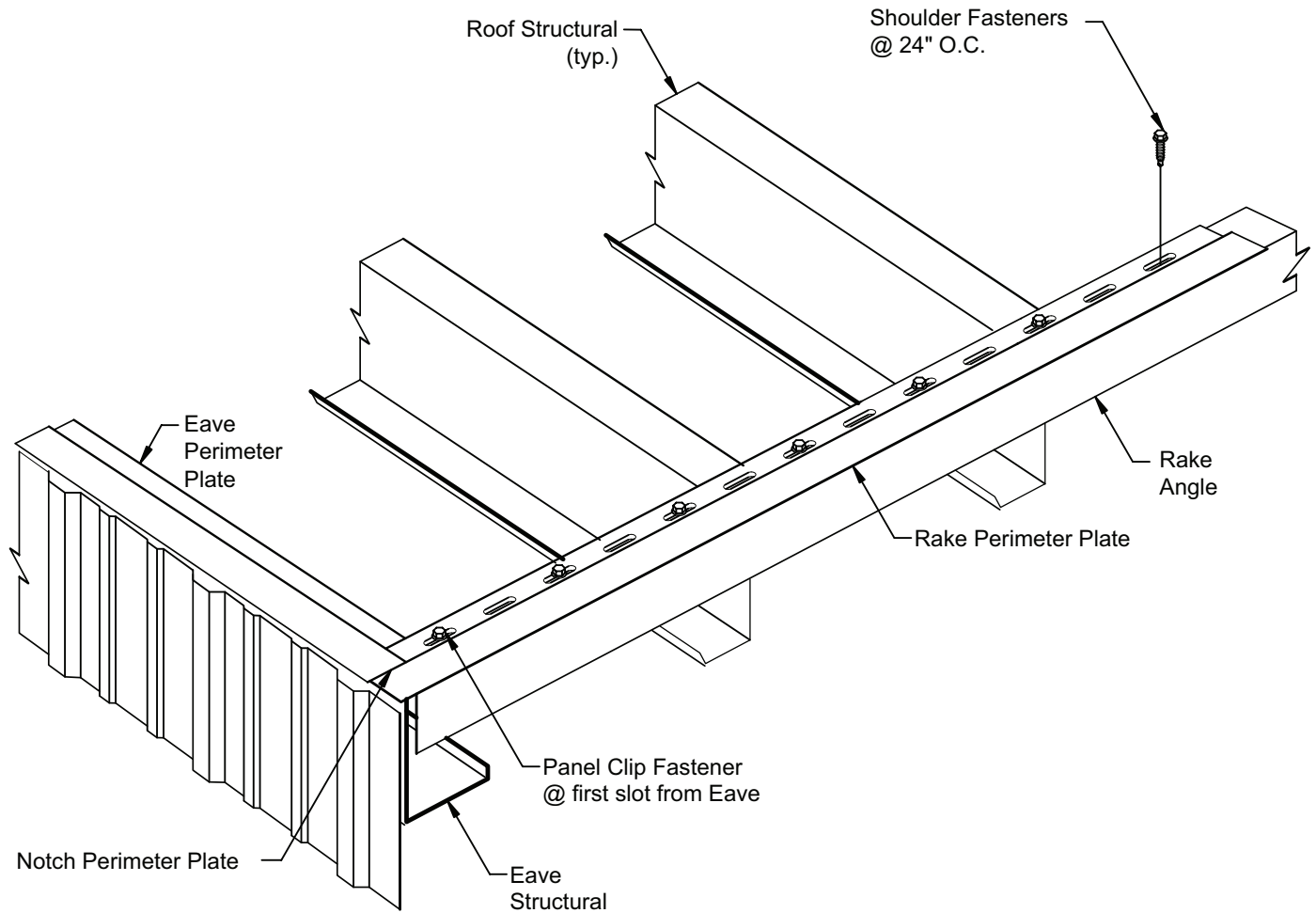

It is important that the rake perimeter plate is installed in a straight line square with the eave.

If the rake angles have been installed straight and true, the edge of the rake angle can be used to align the rake perimeter plate.

If the rake angle is not true and square, a chalkline should be used to guide the installation of the rake perimeter plate.

Start the end of the rake perimeter plate flush with the outer edge of the eave perimeter plate. Notch the bottom flange of the rake perimeter plate to clear the eave perimeter plate.

Secure the starting end of the rake perimeter plate to the rake angle with a panel clip fastener in the rake perimeter plate's first slot.

To allow for expansion/contraction movement, secure the rest of the rake perimeter plate run to the rake angle with **shoulder fasteners** spaced as shown. Install the shoulder fasteners in the center of the slots.



9.5 TERMINATION PANEL INSTALLATION

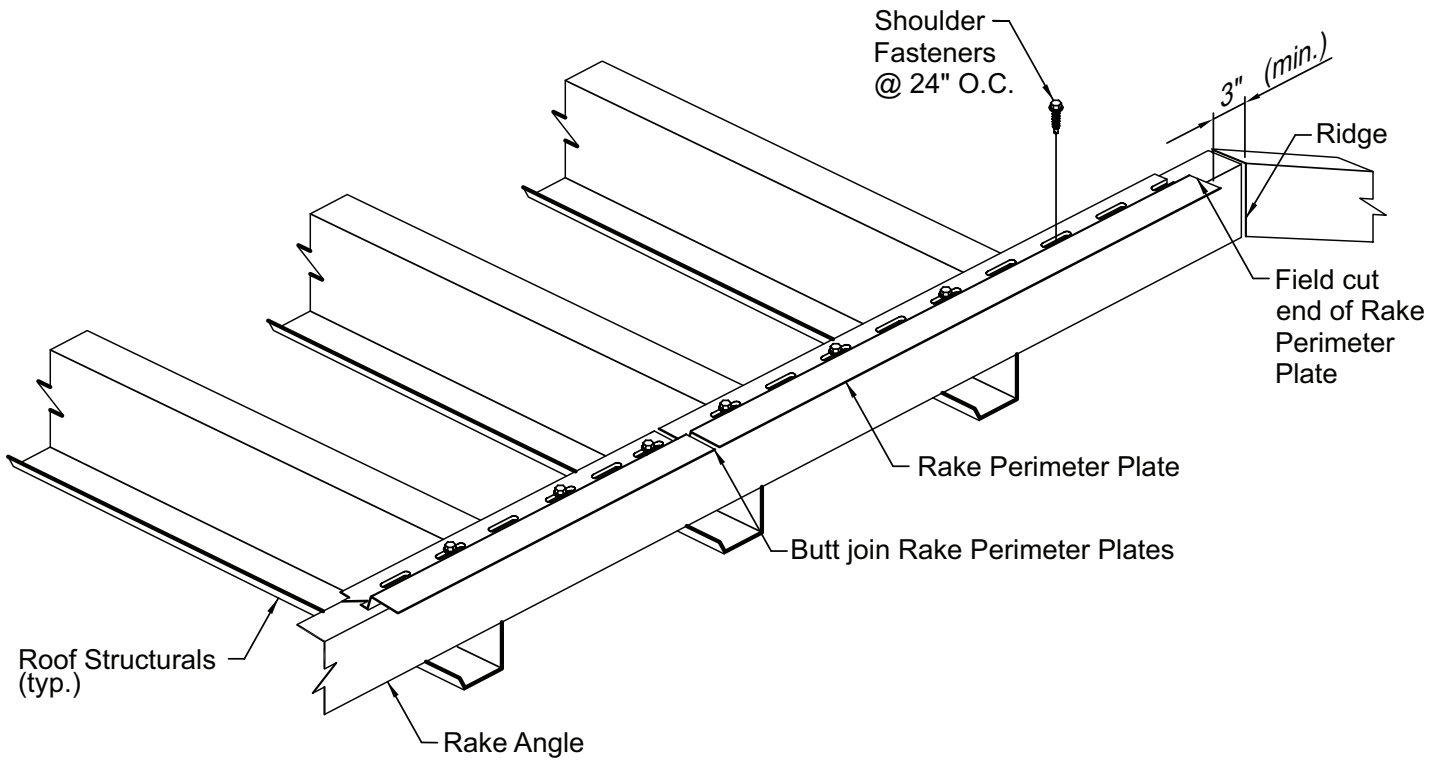

Butt join the ends of the rake perimeter plate and angle. Install the shoulder fasteners in the slots on either side of the butt joints.

Field cut the last rake perimeter plate two inches (3") from the ridge line or high eave line.

9.5 TERMINATION PANEL INSTALLATION

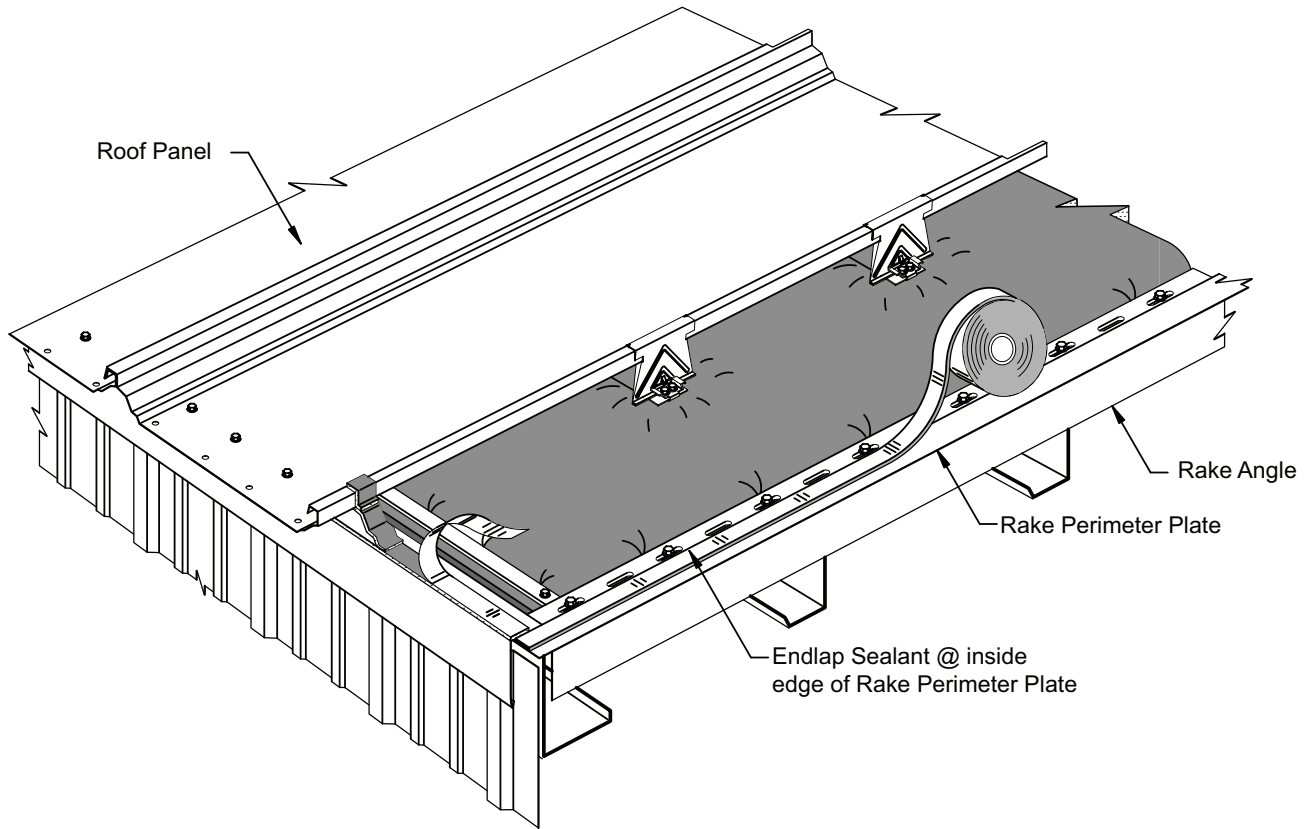

Install end lap sealant along the top flange of the rake perimeter plate as shown.

Do not remove the protection paper until immediately before installing the termination roof panel.

Position the edge of the sealant flush with the inside edge of the rake perimeter plate bend. At the eave, lap the end of the sealant on top of the eave sealant.

9.5 TERMINATION PANEL INSTALLATION

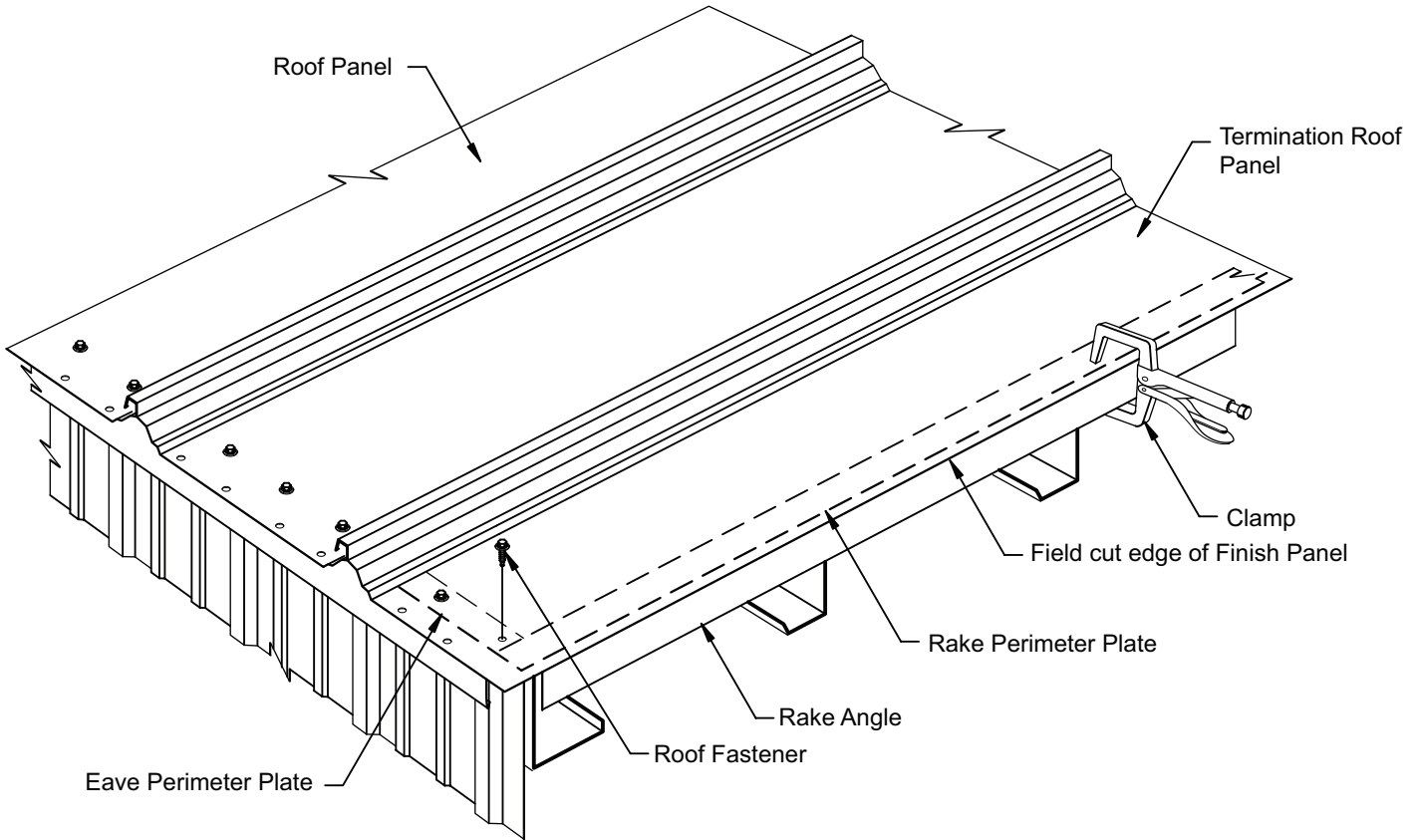

Field cut the termination roof panel to the required width. The cut edge of the panel should extend 1" beyond the outer edge of the rake perimeter plate's top flange.

Along the cut edge of the termination roof panel, wipe the underside clean and dry.

Remove the protective paper from the eave sealant and rake plate sealant.

Install the termination panel into position as shown.

Install the eave fasteners and temporarily clamp the edge of the panel to the rake perimeter plate.

9.5 TERMINATION PANEL INSTALLATION

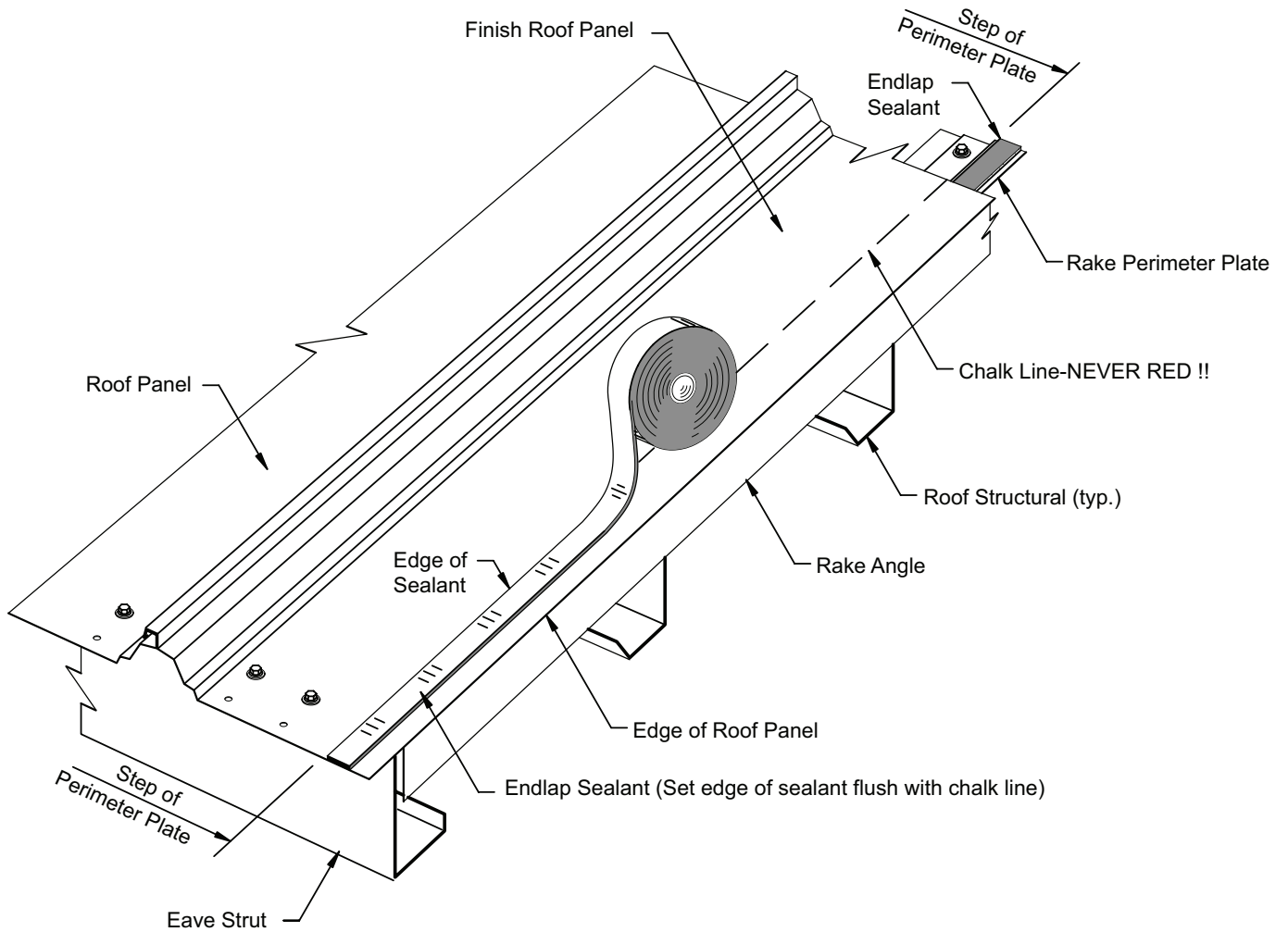

Along the cut edge of the termination roof panel, wipe the top surface clean and dry.

Install endlap sealant continuous along the edge of the termination roof panel as shown.

The rake closure sealant must be positioned directly over the rake perimeter plate's top flange. Layout the sealant location on the panel's top surface with a chalk line as shown. Align the chalk line with the rake plate's step. No red chalk.

Position the edge of the sealant on the chalk line. Start and finish the ends of the sealant flush with the ends of the roof panel.

Check the entire length of the sealant to assure that it is correctly positioned and that there are no voids or thinned areas.

After the sealant has been correctly installed, lightly press the sealant against the roof panel to assure adhesion. Do not use excess pressure which can thin the sealant.

9.5 TERMINATION PANEL INSTALLATION

IMPORTANT
Install termination zee from ridge to eave to provide watershed at zee splices

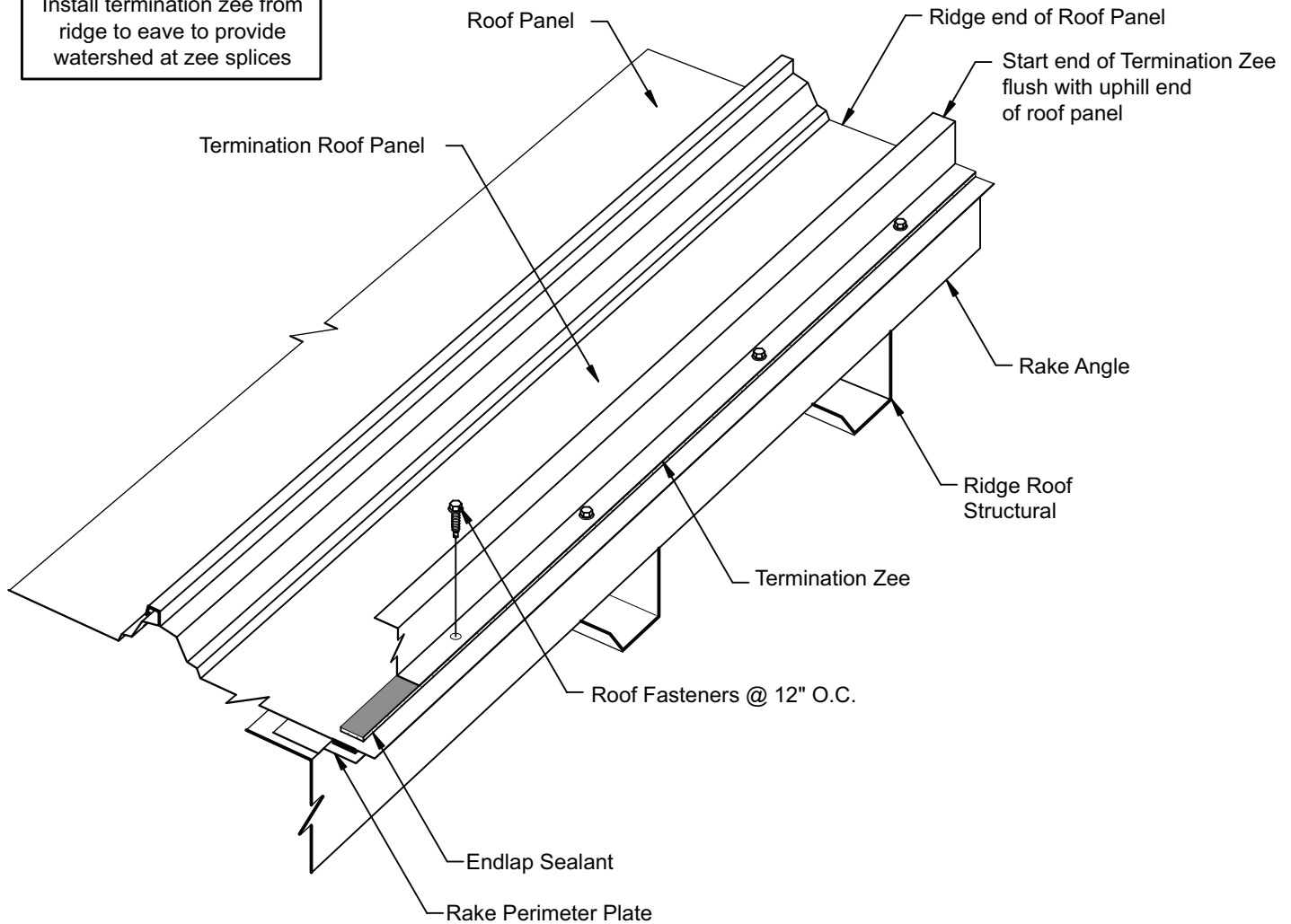

The termination zee must be installed from ridge-to-eave to provide for watershed at the termination zee splices.

Uniformly press the termination zee against the sealant to assure adhesion.

Install the termination zee on top of the sealant as shown.

Attach the termination zee with roof fasteners at 12" spacing. Check that the fasteners penetrate the center of the sealant and securely engage the rake plate.

Position the termination zee so its bottom flange is turned outward and its inside edge is flush with the inside edge of the sealant. Position the end of the termination zee flush with the uphill end of the roof panel.

9.5 TERMINATION PANEL INSTALLATION

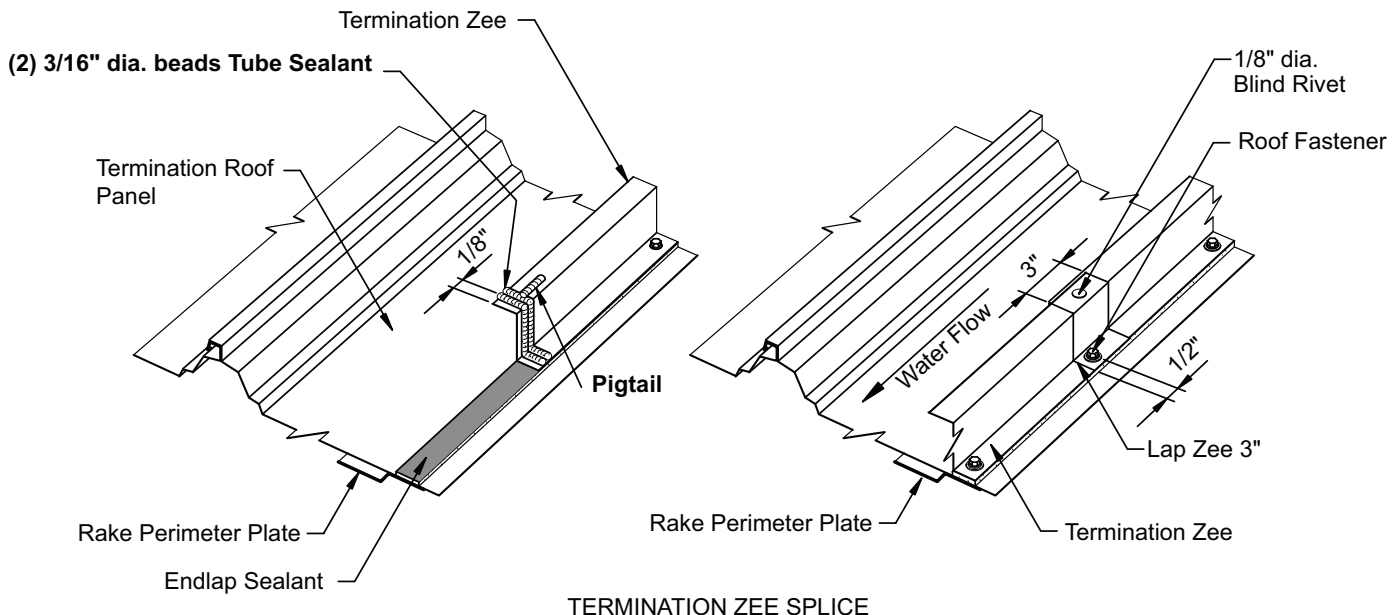

TERMINATION ZEE SPLICE

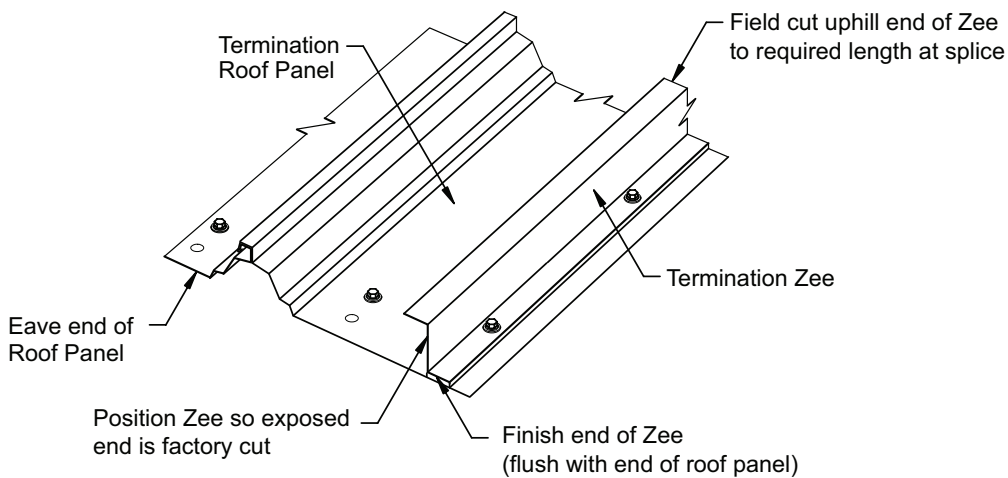

TERMINATION ZEE AT EAVE

Apply two 3/16" beads of tube sealant along the downslope end of the termination zee as shown.

Position the next downhill zee, overlapping the previously installed zee by 3".

Clamp the lapped zee while installing the fasteners.

Attach the next zee with roof fasteners.

Install the first fastener through the lapped bottom flanges.

Install a 1/8" pop rivet through the lapped upper flanges.

Position the last zee so its down slope end is flush with the eave end of the roof panel. Then cut the up-slope end for a 3" lap at the splice.



9.5 TERMINATION PANEL INSTALLATION

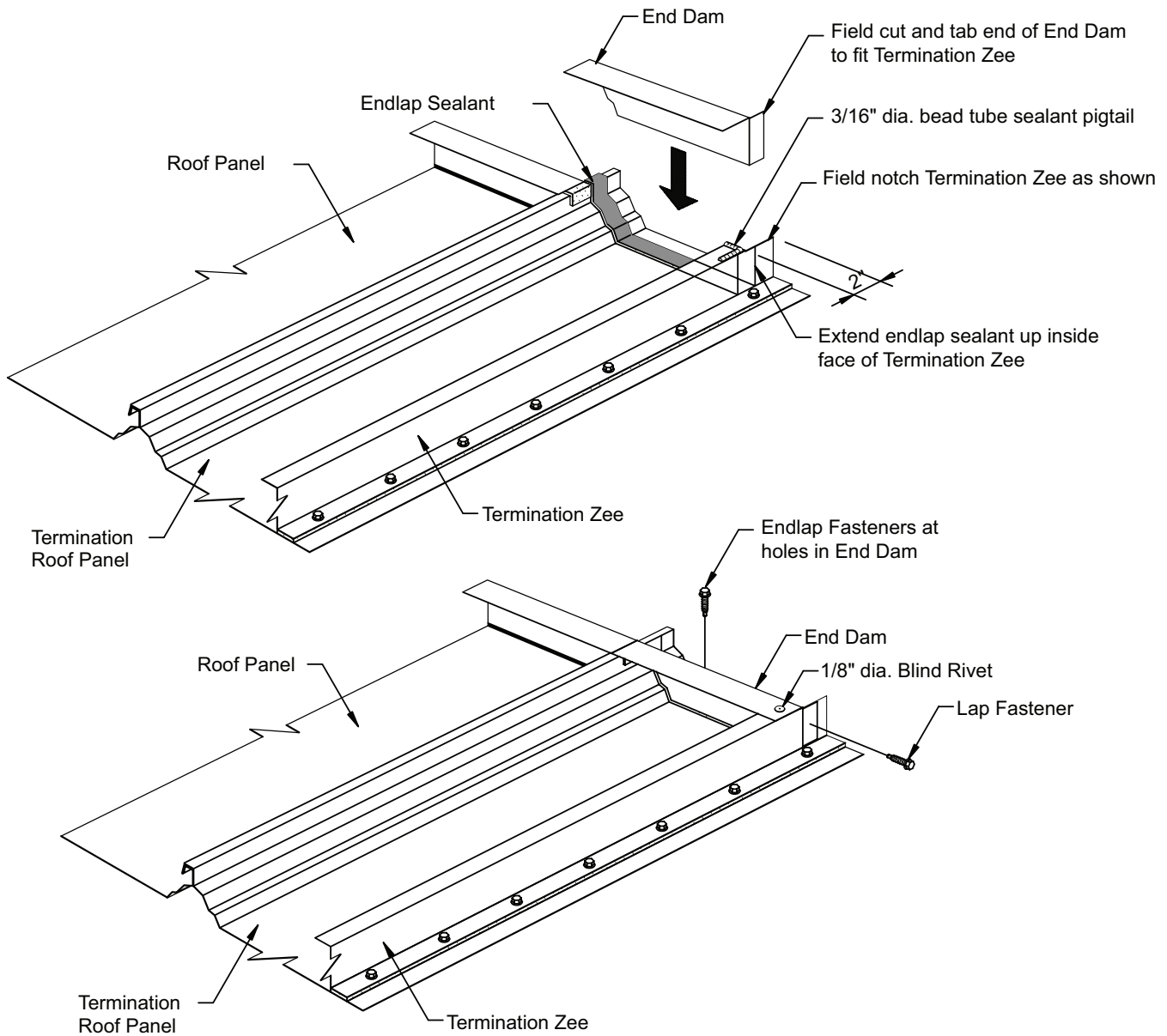

An end dam must be field modified to fit between the roof panel rib and the termination zee.

Field modify the end dam as shown above and install as shown.

Install the ridge sealant to extend up the face of the termination zee as shown.

9.6 RAKE TRIM INSTALLATION

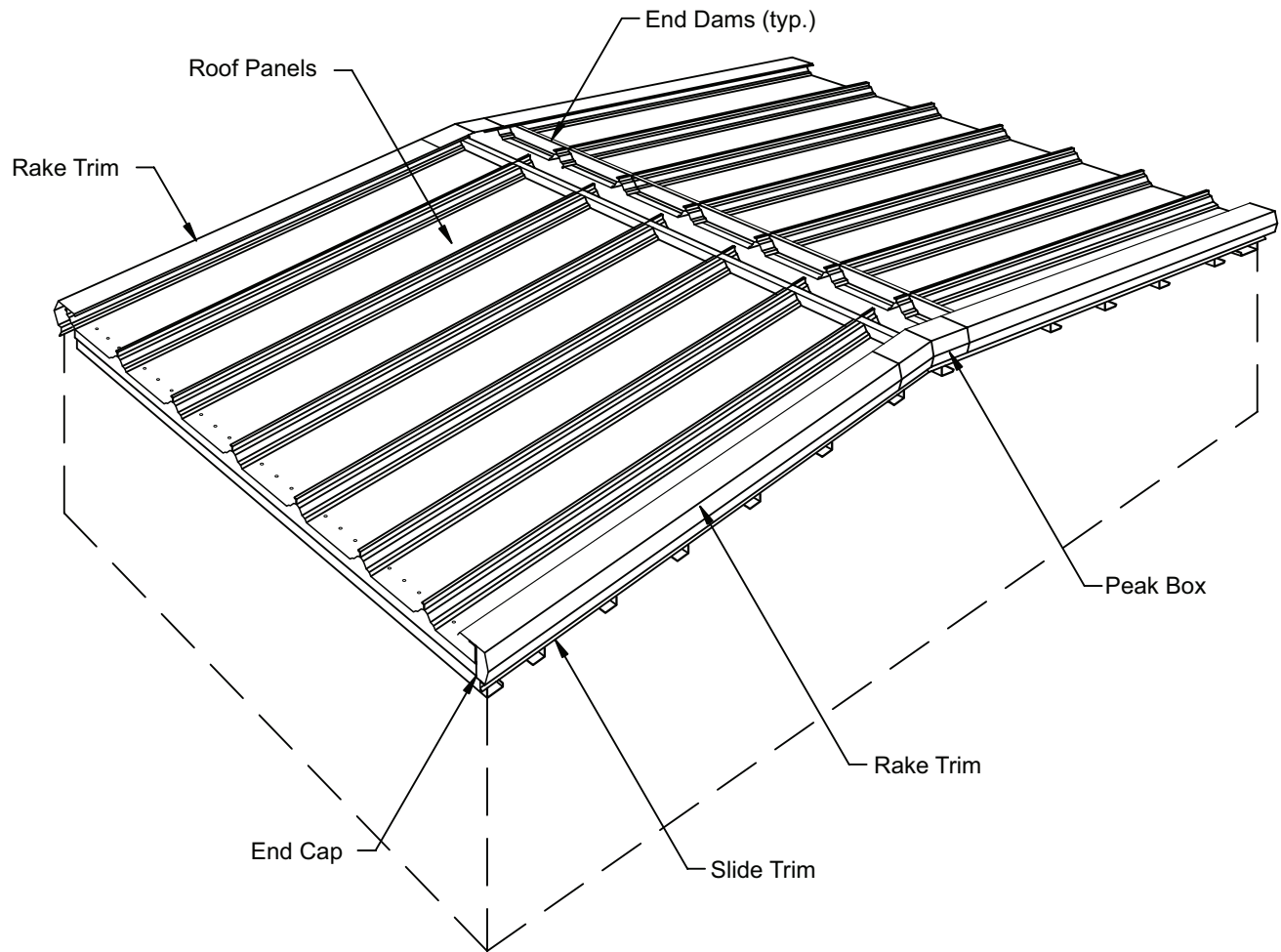

The details in this section show the installation of the rake trim, peak box, and end caps.

condition. The details at a starting roof panel condition are similar.

These details show the rake trim at a termination roof panel

9.6 RAKE TRIM INSTALLATION

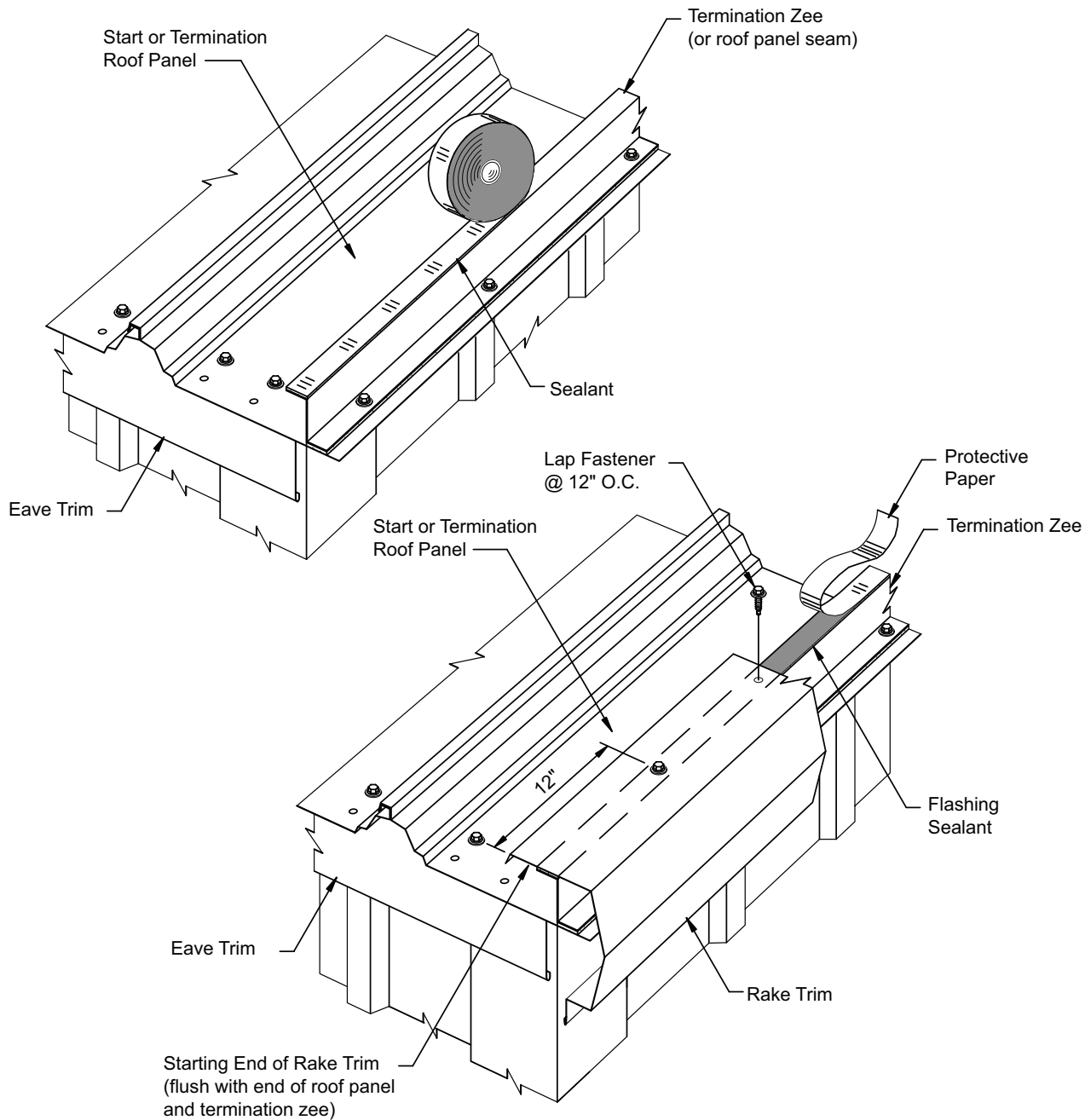

Install the rake trim from eave to ridge to provide for watershed at the splices.

Install flashing sealant continuous along the top flange of the termination zee (or roof panel seam).

Start the down-slope end of the rake trim flush with the end of the roof panel.

Check that the rake trim is properly aligned with the face of the wall panel.

Fasten the rake trim to the termination zee with lap fasteners at 12" spacing, as shown. **Be sure fasteners do not penetrate the start clip tabs and are 2" from clip ends.**

Be sure to check that the fasteners penetrate the center of the sealant and securely engage the termination zee (or roof panel seam).

9.6 RAKE TRIM INSTALLATION

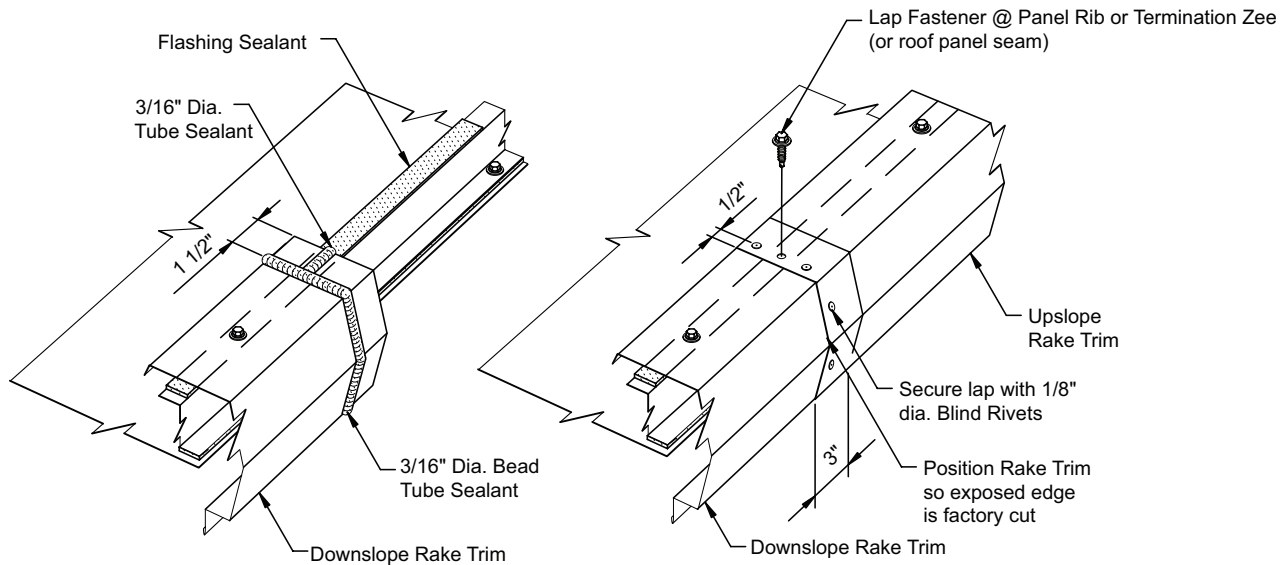

RAKE TRIM SPLICE

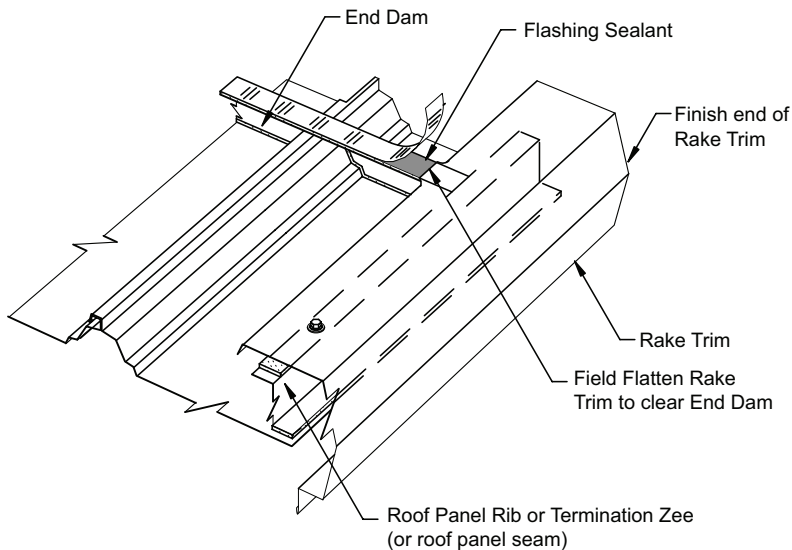

RAKE TRIM @ RIDGE

Assemble rake trim splices with tube sealant and rivets as shown.

At the ridge, field cut the uphill end of the rake trim 2" back from the center line of the ridge.

Field flatten the rake trim's lip to clear the top flange of the end dam.

At a high eave transition, field cut the end of the rake trim as required for a weathertight joint with the adjacent construction.



9.6 RAKE TRIM INSTALLATION

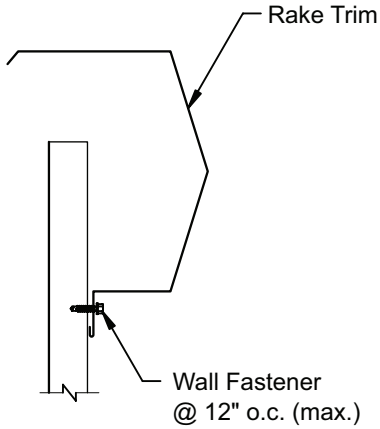

FIXED ATTACHMENT
(25' or less)

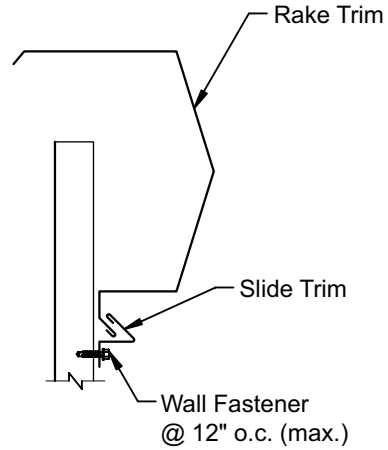

SLIDING ATTACHMENT
(exceeds 25')

IMPORTANT
For rake lengths (eave to ridge) exceeding 25', a sliding type attachment of the rake trim to wall is required.

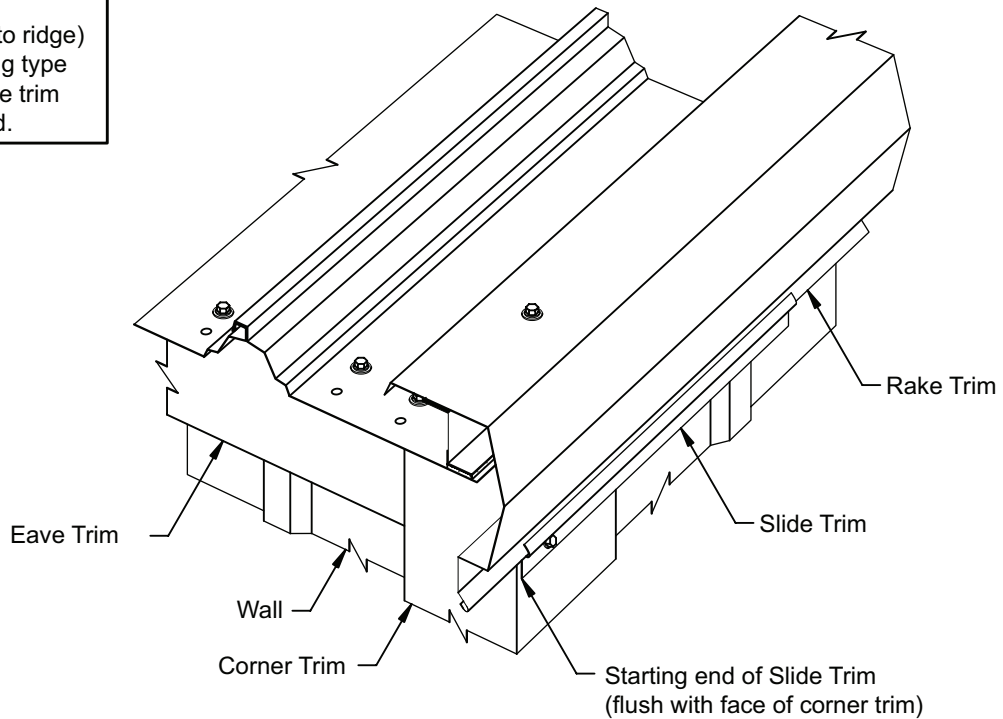

If the rake trim run is 25' or less, the bottom edge of the rake trim can be attached directly to the wall with wall fasteners as shown.

Install the slide trim continuous along the bottom edge of the rake trim as shown.

If the rake trim run exceeds 25', the bottom edge of the rake trim must be secured with the slide trim to allow for roof expansion/contraction.

In all cases, the bottom edge of the rake trim must be installed straight and parallel to the roof line. Use a chalk line to guide the alignment of the rake trim's bottom edge.

9.6 RAKE TRIM INSTALLATION

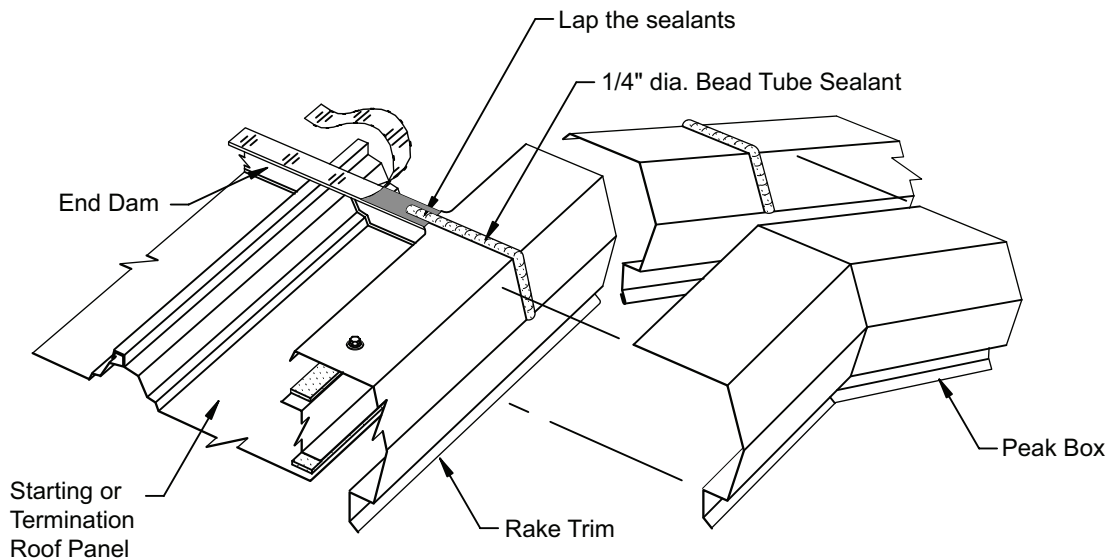

NOTE
 If slide trim is not required, attach Peak Box to Rake Trim with 1/8" dia. blind rivets.

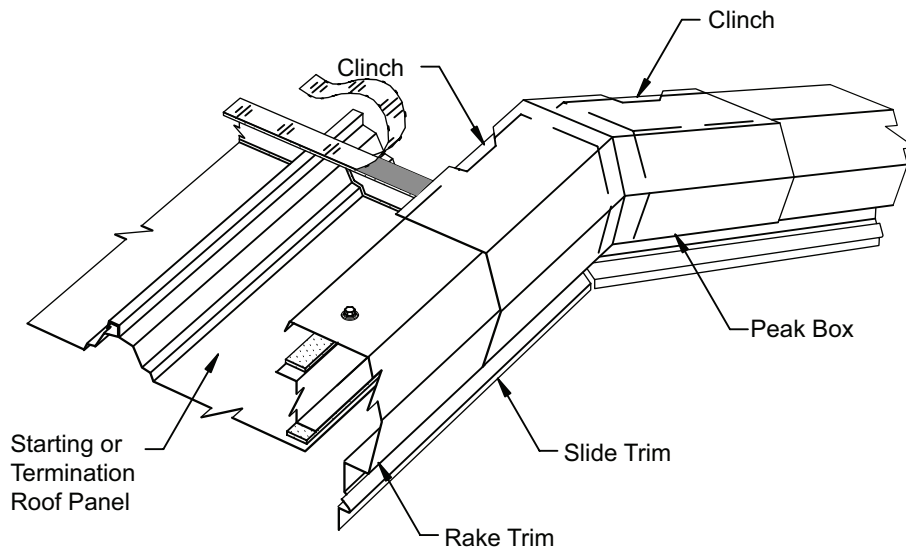

If the rake trim does not require the slide trim for expansion/ contraction, the peak box can be installed with tube sealant and rivets in the same manner as a splice.

If the rake trim requires the slide trim for expansion/ contraction, the peak box must be installed as shown in the above details.

Secure the top of the peak box by clinching its top edge around the top edge of the rake trim.

Secure the bottom edge of the peak box with the slide trim.



9.6 RAKE TRIM INSTALLATION

NOTE
 Rake Trim End Cap is not required
 when eave has Eave Gutter
 or Eave Box Trim

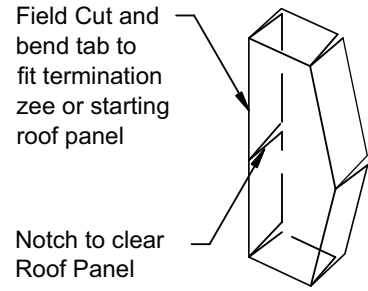

END CAP DETAIL

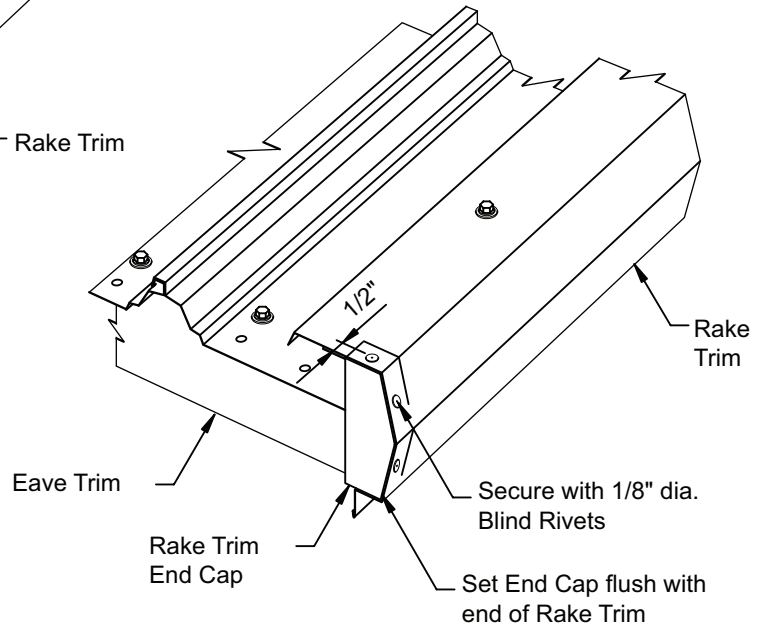
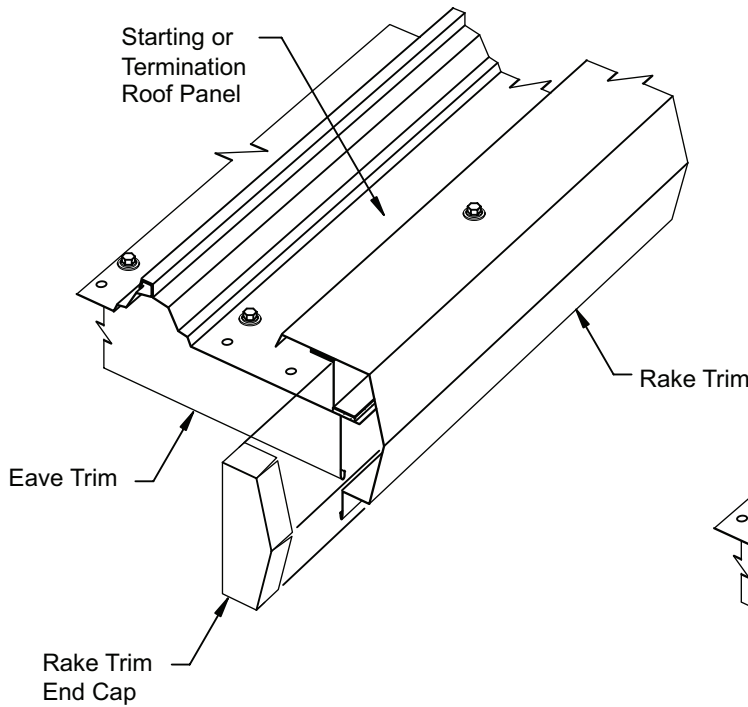

The rake trim end cap is only required for roof applications without eave gutter.

Install the end cap with tube sealant and rivets in the same manner as a splice.

The end cap must be field cut and a tab bent to fit the termination zee or starting roof panel as shown.

9.7 RAKE TRANSITION INSTALLATION

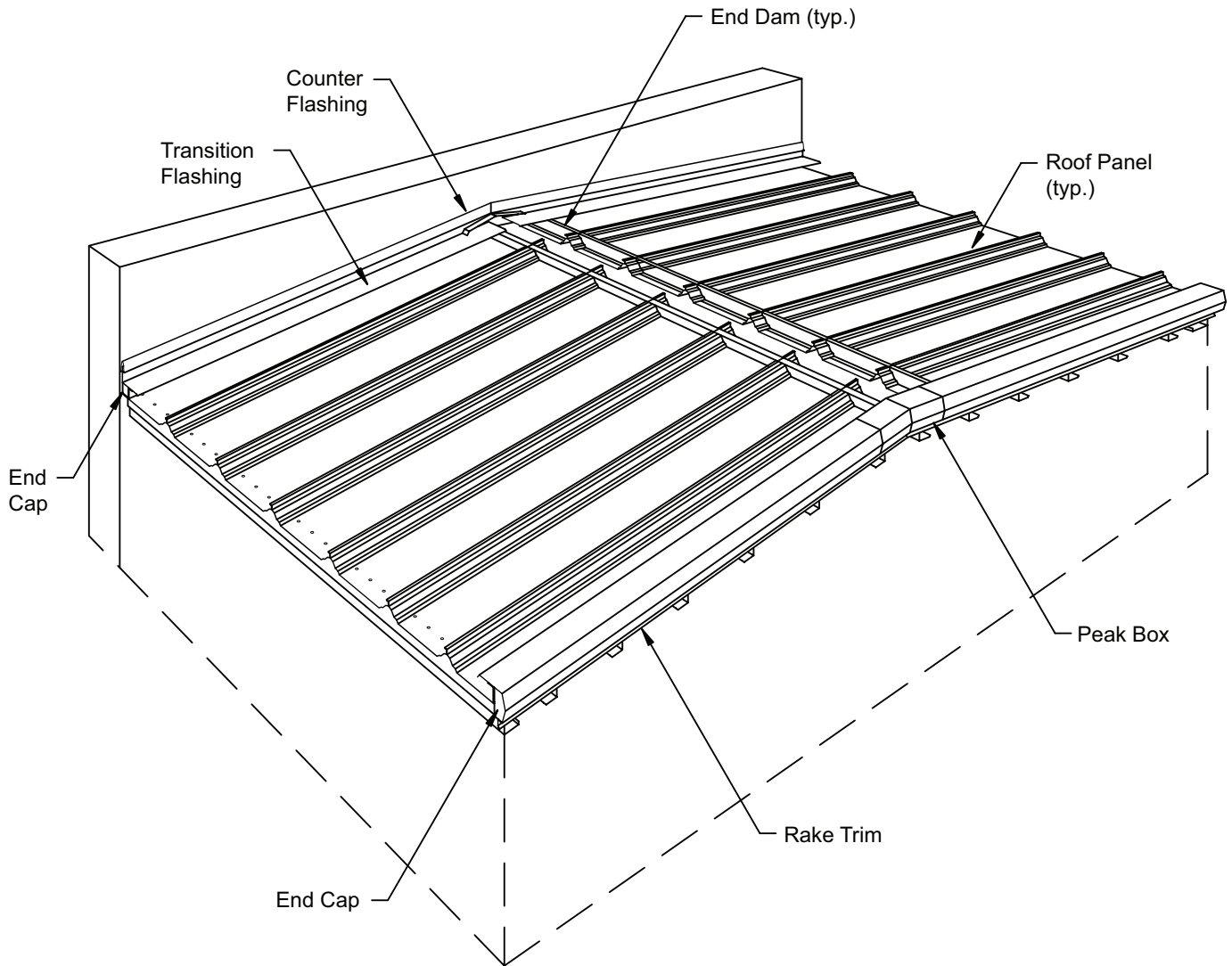

The details in this section show the installation of the rake transition flashing.

Counter flashing details are not shown. Refer to the erection drawings for the required counter flashing.

In all cases, verify that counter flashing will:

1. Allow expansion/contraction of the transition flashing.
2. Restrain the transition flashing during roof live loads and wind loads.
3. Provide a weather resistant seal between the transition flashing and the wall.

9.7 RAKE TRANSITION INSTALLATION

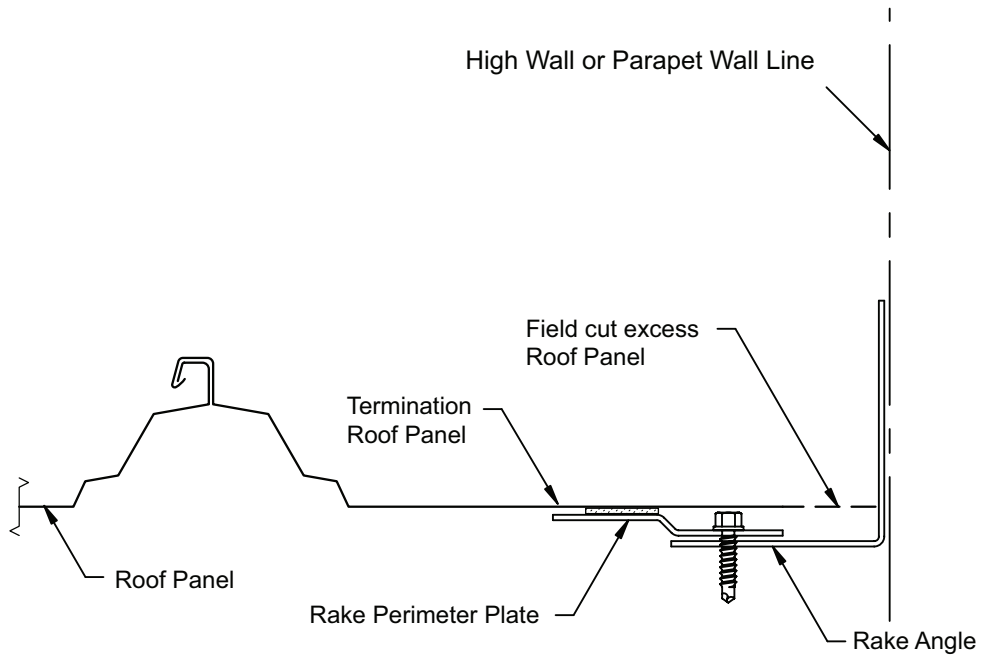

RAKE PERIMETER PLATE AT HIGH WALL

For rake to wall transition conditions, position rake perimeter plate as shown.

Refer to the erection drawings for the required spacing of the rake perimeter plate from the face of the rake angle.

9.7 RAKE TRANSITION INSTALLATION

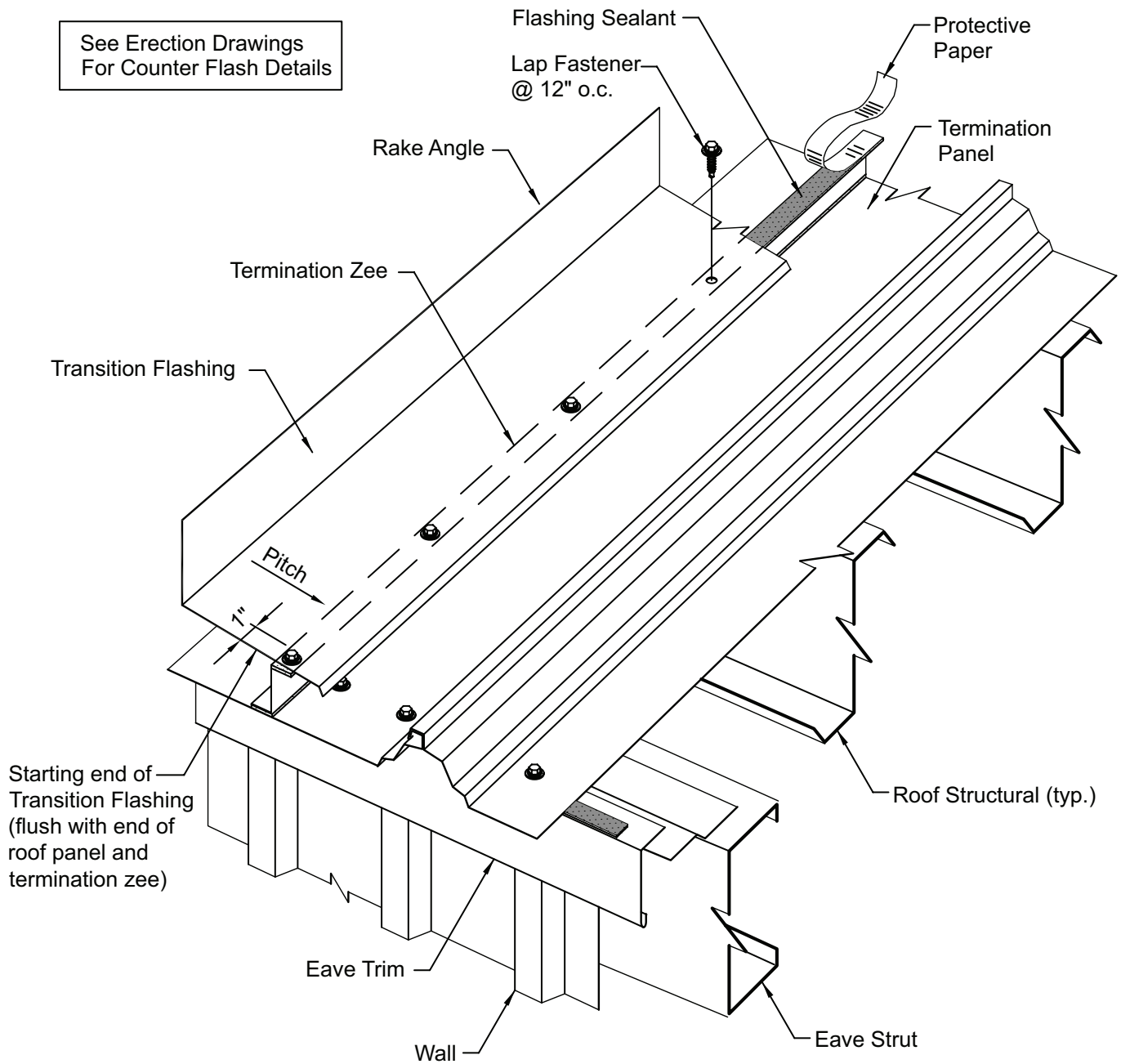

Install the transition flashing from eave to ridge to provide for watershed at the splices.

Be sure to raise the vertical leg of the transition flashing to provide a positive pitch and assure watershed.

Install flashing sealant continuous along the top and bottom flange of the termination zee. Make sure bottom flange is turned toward the wall.

Attach the flashing to the termination zee with lap fasteners at 12" spacing as shown.

Start the downslope end of the transition flashing flush with the end of the roof panel and position the back leg flush with the rake angle or wall construction as required.

Check that the fasteners penetrate the center of the sealant and securely engage the termination zee.



9.7.3 START TRANSITION FLASHING AT EAVE

9.7 RAKE TRANSITION INSTALLATION

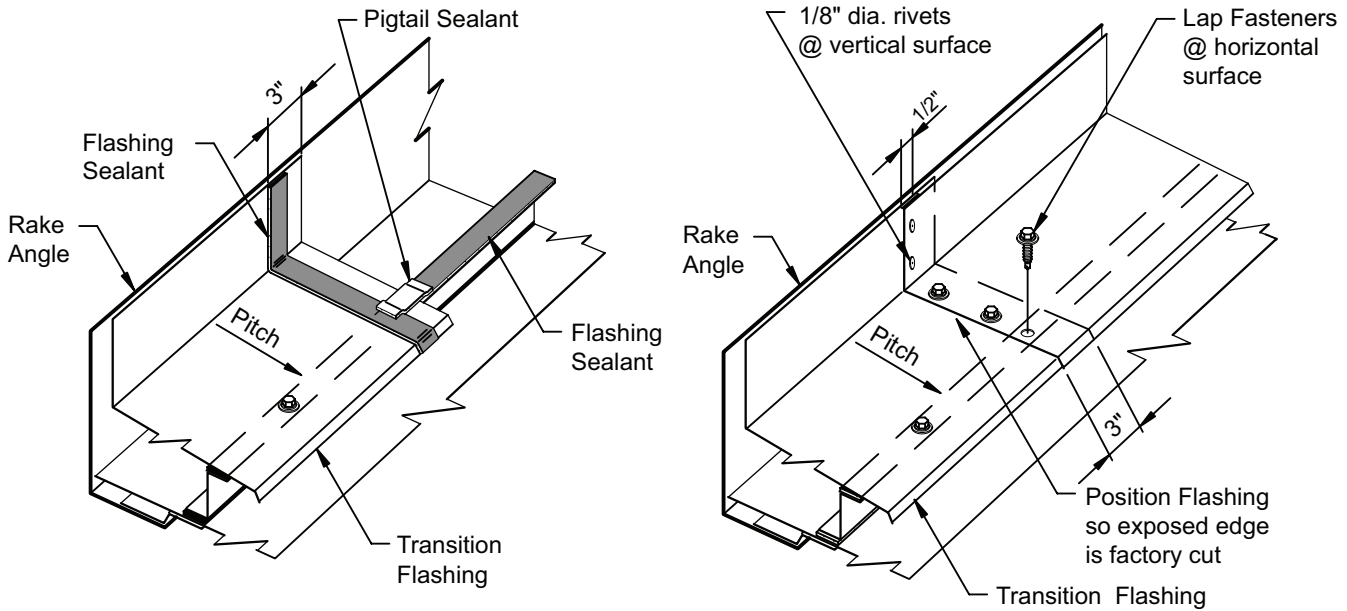

TRANSITION FLASHING SPLICE

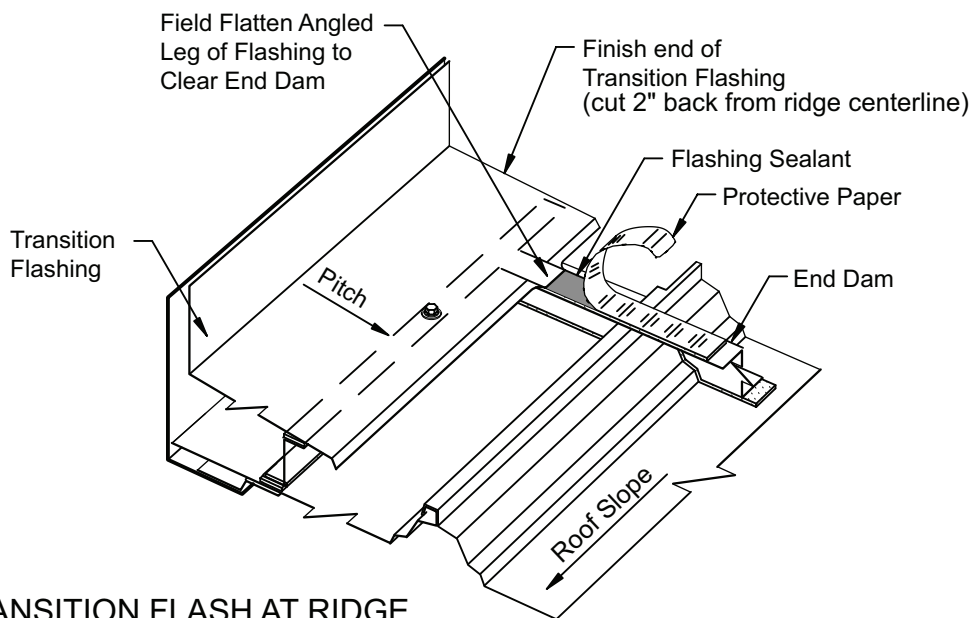

TRANSITION FLASH AT RIDGE

Assemble transition flashing splices with flashing sealant and lap fasteners as shown. Wipe dry and clean the lapping surfaces of the flashing.

Field Flatten the flashing's lip to clear the top flange of the end dam.

At the ridge, field cut the end of the flashing 2" away from the center line of the ridge.

At a **high eave transition**, field cut the end of the flashing as required for a weathertight joint with the adjacent construction.

9.8 RIDGE COVER INSTALLATION

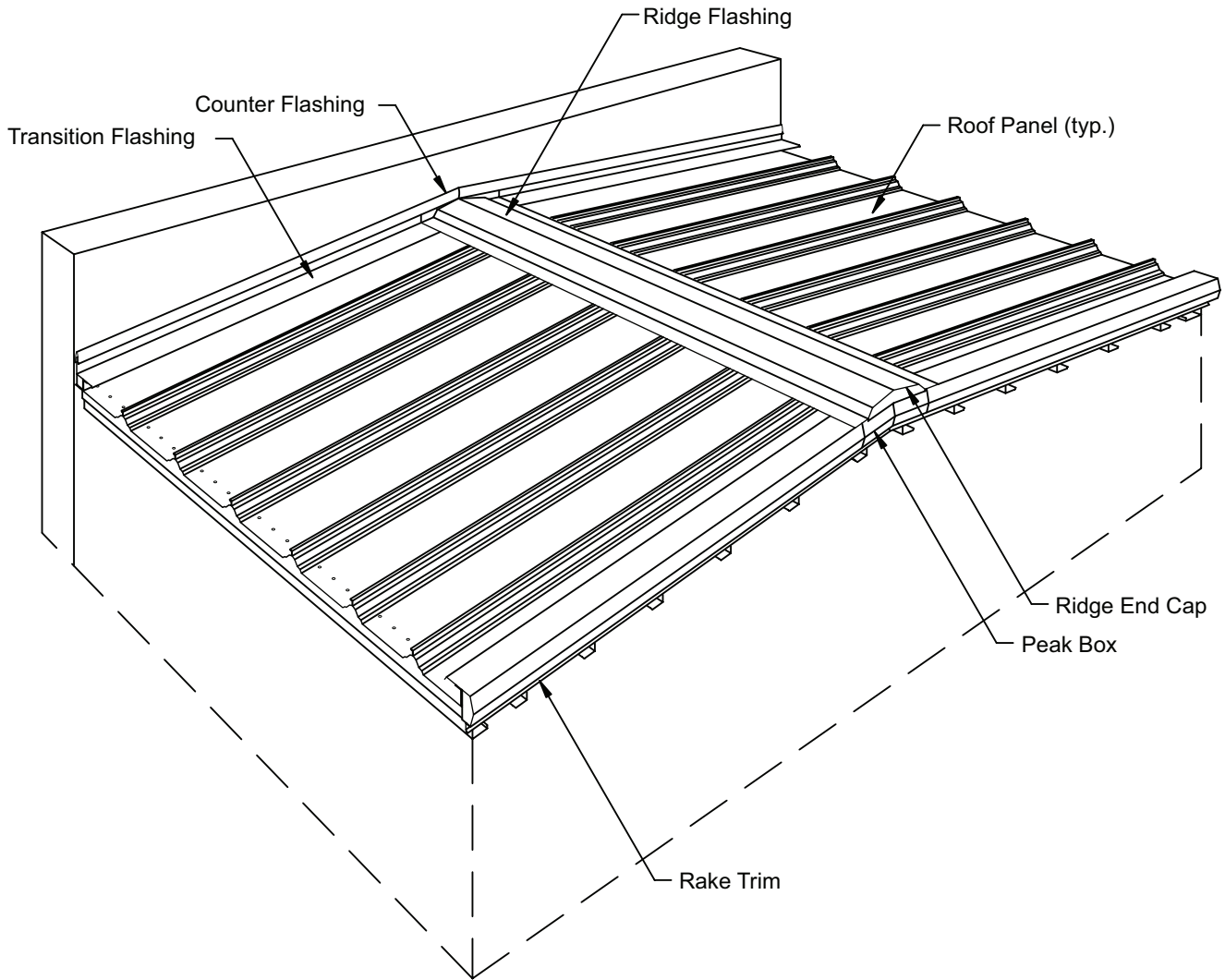

The details in this section show the installation of the ridge cover.

The ridge cover can start or finish at either a rake trim condition or a rake transition condition.



9.8.1 ORIENTATION VIEW

9.8 RIDGE COVER INSTALLATION

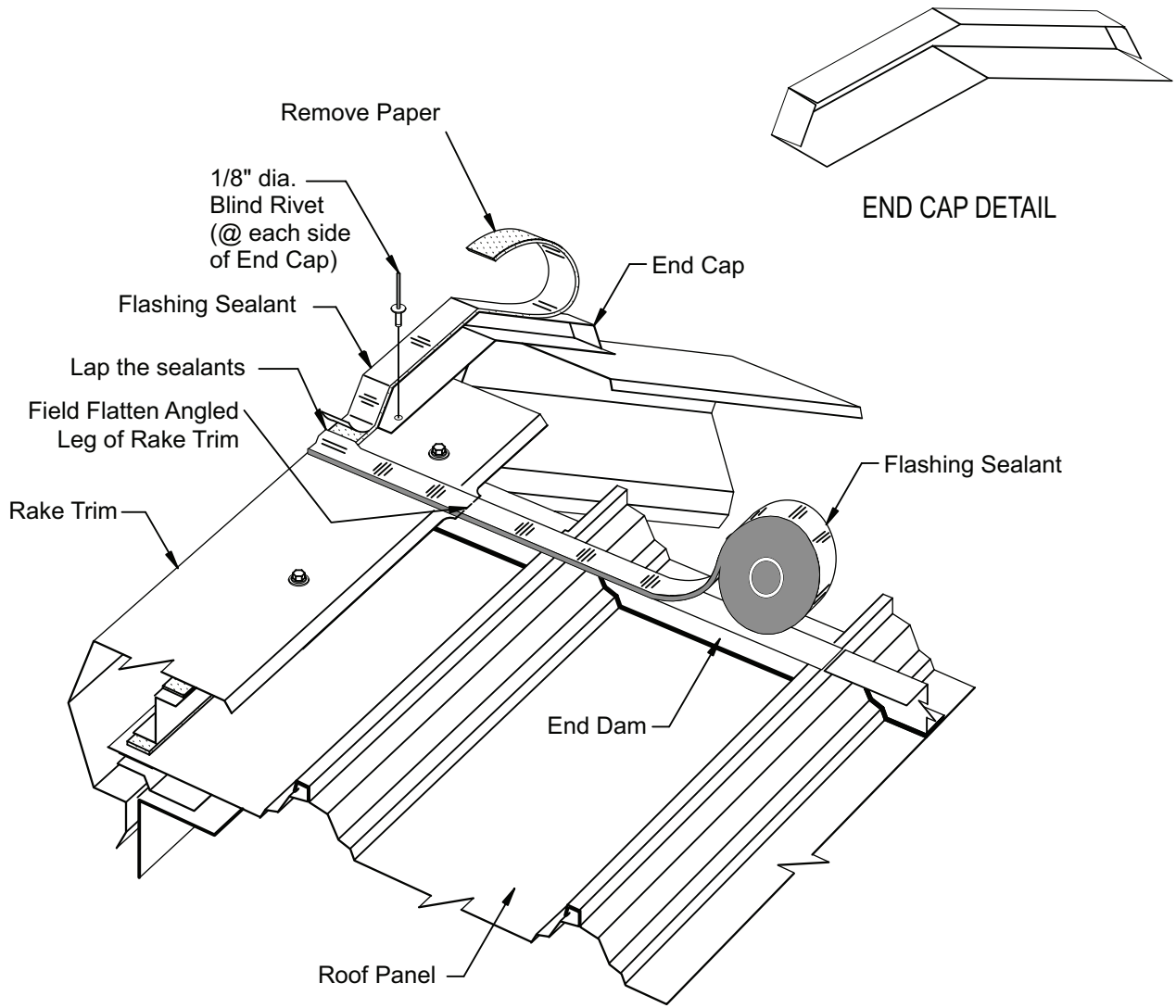

Note: Opposite slope roof panels omitted for clarity.

Position the end cap so its face is flush with the face of the rake trim.

Install flashing sealant continuous along the top flange of the end dams. Lap the end of the sealant over the end cap sealant.

Fasten the end cap to the rake trim with (2) rivets as shown.

Install flashing sealant on top of the end cap as shown. Align the edge of the sealant flush with face of the end cap and extend the sealant to align with the end dams.

9.8 RIDGE COVER INSTALLATION

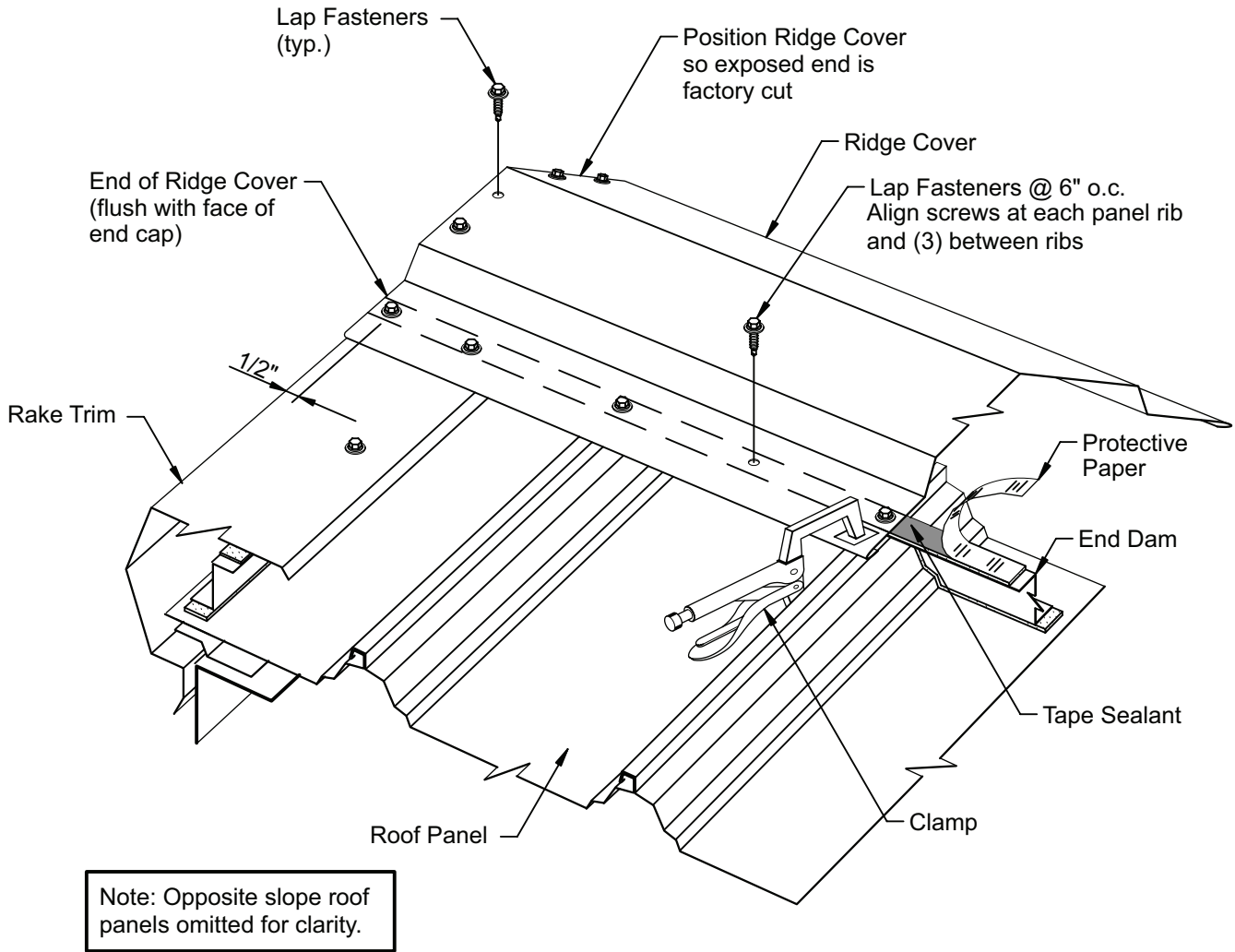

Install the ridge cover to span across the opposing end dams run as shown.

Position the end of the ridge cover flush with the face of the end cap.

Align the center of the ridge cover over the ridge centerline. Use a string line to assure a straight ridge cover installation.

Fasten the ridge cover to the end dams with lap fasteners

spaced as shown. Check that the fasteners penetrate the center of the sealant and securely engage the termination zee.

Important: To provide watershed, the ridge cover must have a positive pitch, even during roof panel contraction.

To increase the ridge cover's pitch, first fasten only one edge of the ridge cover, then push on the opposite edge of the ridge cover to deflect its center upward. Hold it in this position with clamps while fastening the other edge.



9.8.3 INSTALL RIDGE COVER AT RAKE TRIM

9.8 RIDGE COVER INSTALLATION

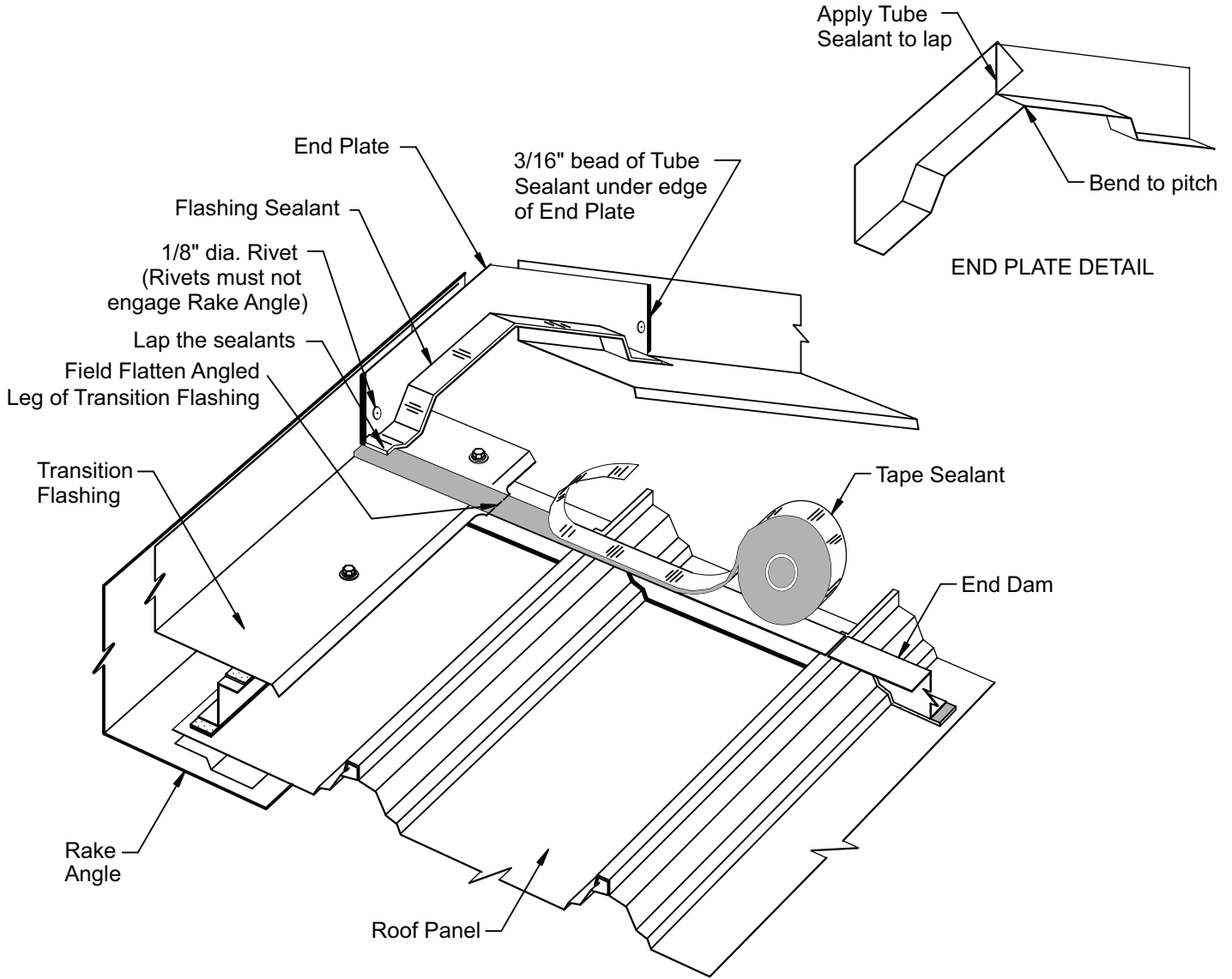

Note: Opposite slope roof panels omitted for clarity.

Position the end plate so its face is flush with the face of the transition flashing.

the transition flashing and extend the ends of the sealant to align with the end dams.

Fasten the end plate to the transition flashing with rivets as shown.

Install flashing sealant continuous along the top flange of the end dams. Lap the end of the sealant over the end cap.

Install flashing sealant on top of the end plate as shown. Position the edge of the sealant flush against the face of



9.8 RIDGE COVER INSTALLATION

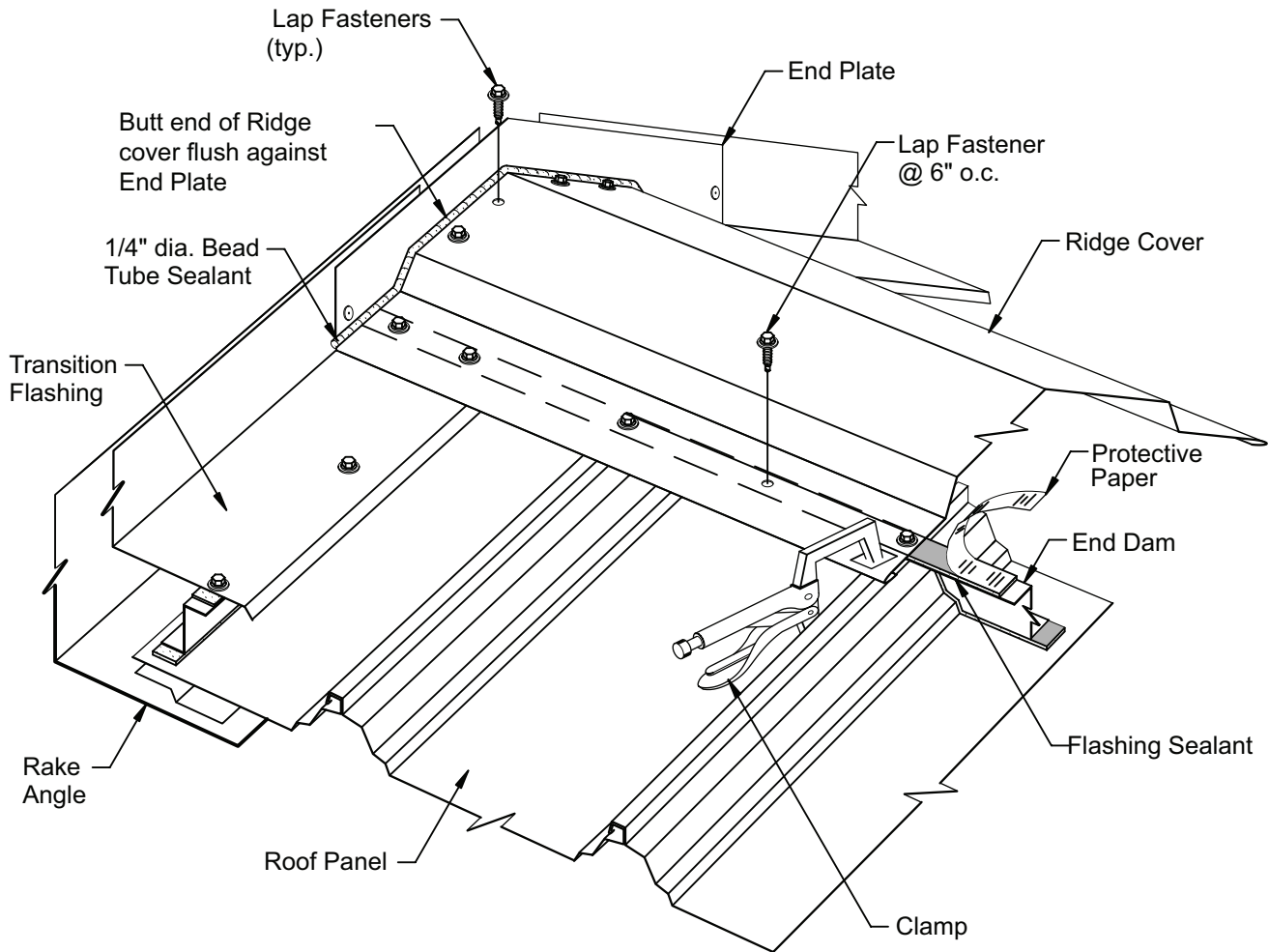

Note: Opposite slope roof panels omitted for clarity.

Install the ridge cover to span across the opposing end dam runs as shown.

Position the end of the ridge cover flush against the face of the transition flashing.

Align the center of the ridge cover over the ridge centerline. Use a string line to assure a straight ridge cover installation.

Fasten the ridge cover to the end dams with lap fasteners

spaced as shown. Check that the fasteners penetrate the center of the sealant and securely engage the termination zee.

Important: To provide watershed, the ridge cover must have a positive pitch, even during roof panel contraction.

To increase the ridge cover's pitch, first fasten only one edge of the ridge cover, then push on the opposite edge of the ridge cover to deflect its center upward. Hold it in this position with clamps while fastening the other edge.



9.8.5 INSTALL RIDGE COVER AT RAKE TRANSITION

9.8 RIDGE COVER INSTALLATION

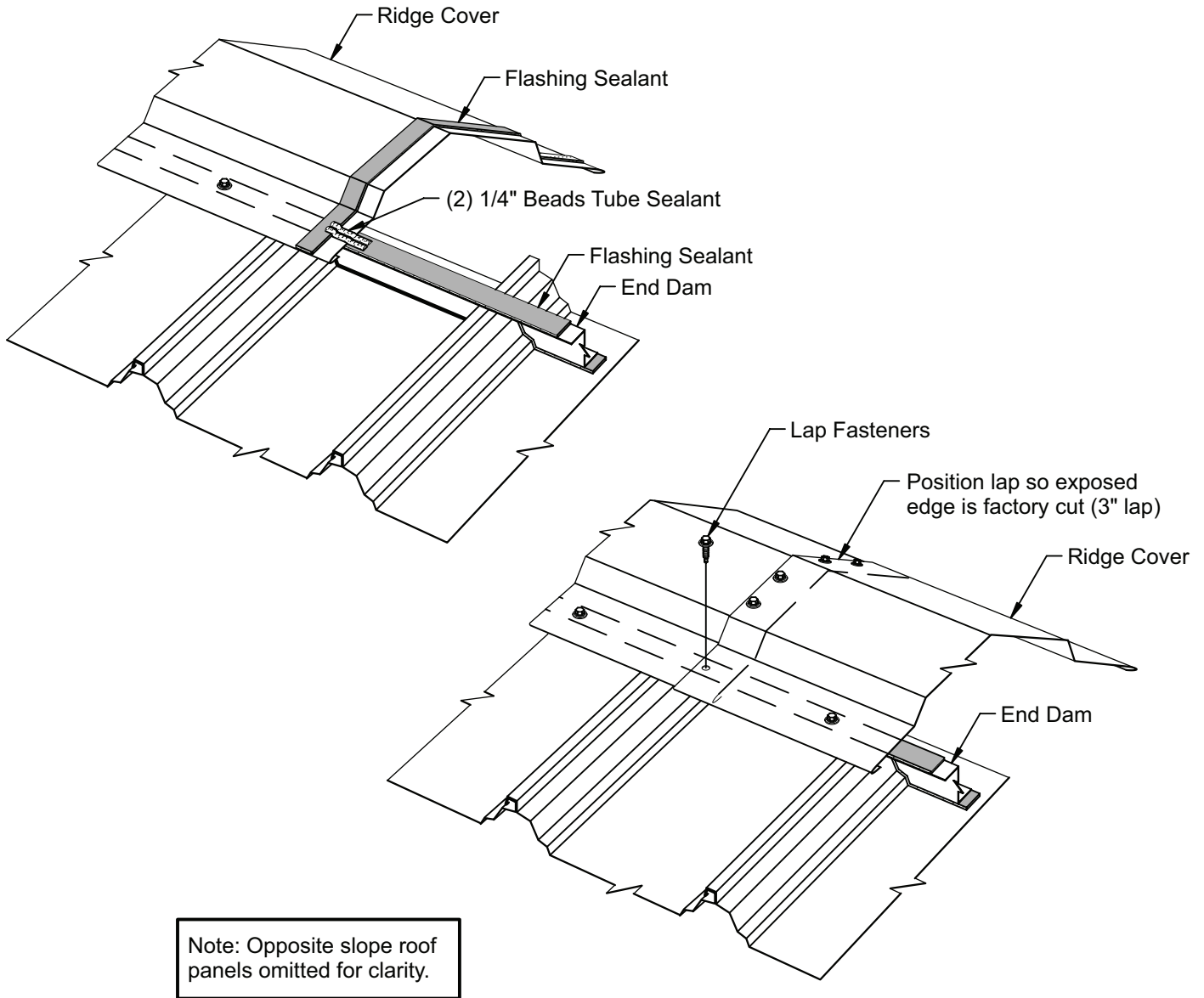

Assemble the ridge cover splices with flashing sealant and lap fasteners as shown.

Important: The splice fasteners must be installed carefully to avoid downward deflection and buckling of the ridge cover ends.

9.9 HIGH EAVE TRANSITION INSTALLATION

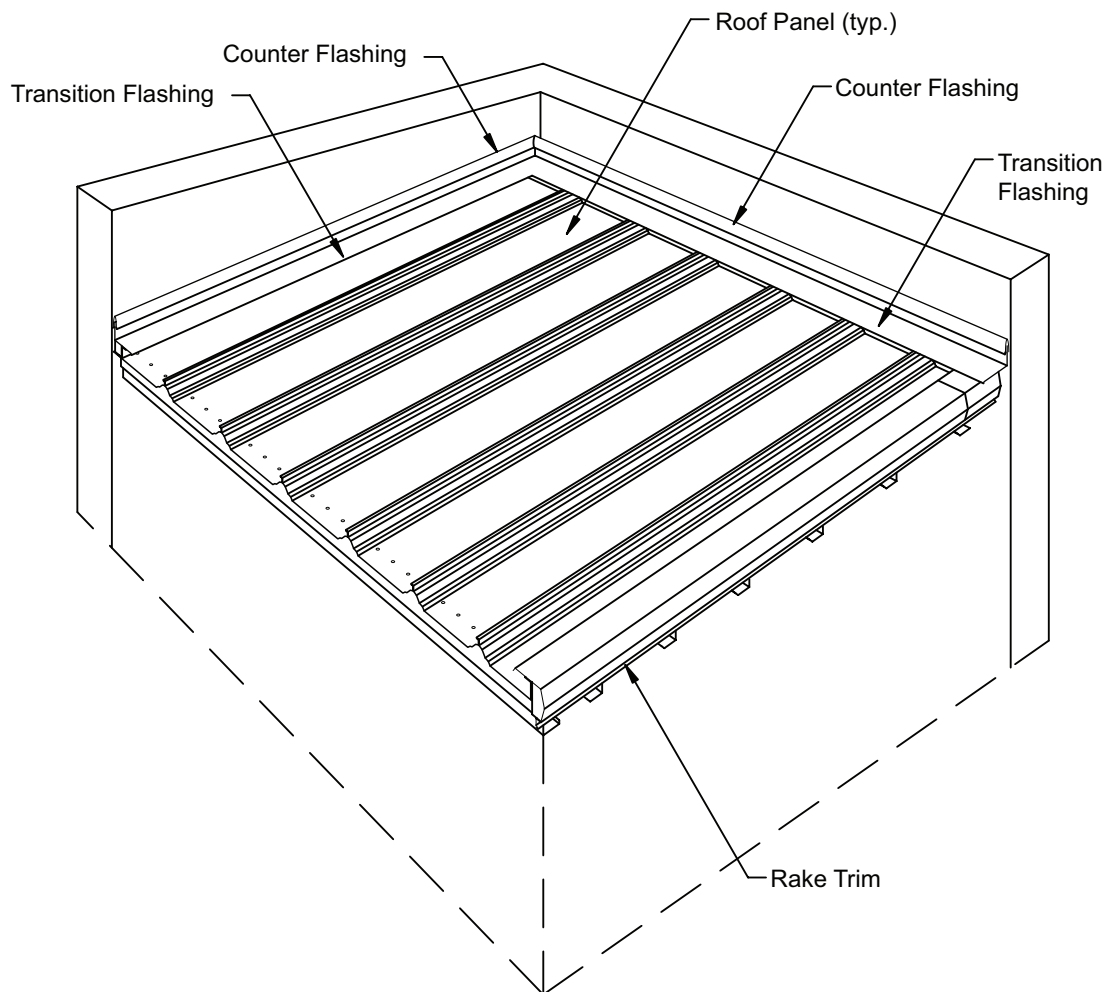

The details in this section show the installation of high eave transition flashing.

The transition flashing can start or finish at either a rake trim condition or a rake transition condition.

In all cases, verify that counter flashing will:

1. Restrain the transition flashing during roof live loads and wind loads.
2. Provide a weather resistant seal between the transition flashing and the wall.

9.9 HIGH EAVE TRANSITION INSTALLATION

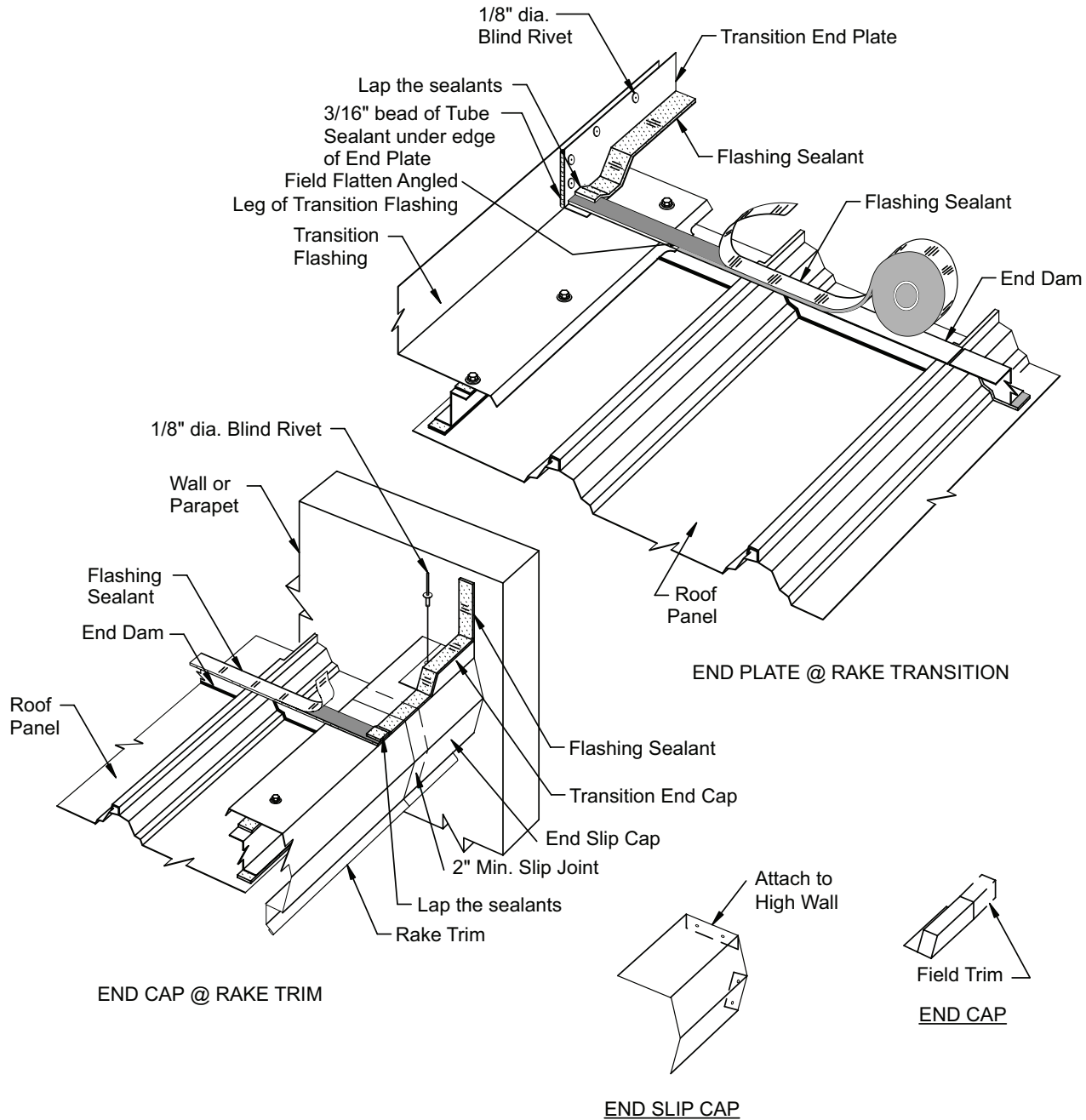

Install end slip cap to wall using gable trim to locate position

Field cut the end cap or end plate to fit as shown.

Position the transition end plate so its face is flush with the face of the rake trim or transition flashing.

Fasten the end cap or end plate with rivets as shown.

Install flashing sealant on top of the end cap or end plate as shown. Align the edge of the sealant flush with face of the end cap or transition flashing and extend the sealant to align with the end dams.

Install flashing sealant continuous along the top flange of the end dams. Lap the end of the sealant over the end cap sealant.

9.9 HIGH EAVE TRANSITION INSTALLATION

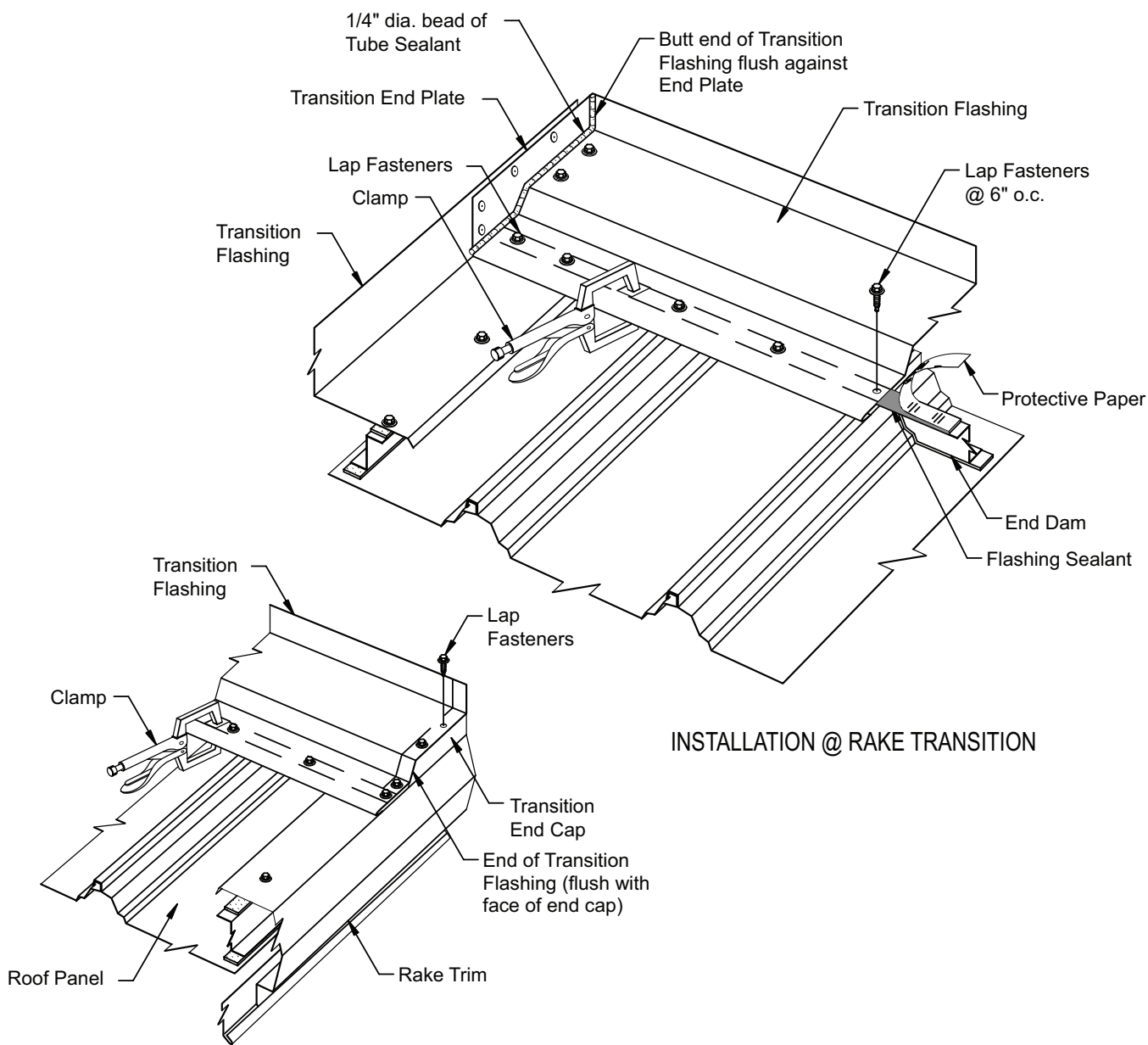

INSTALLATION @ RAKE TRIM

Position the end of the flashing flush with the face of the end cap or rake transition flashing and position the back leg flush with the wall construction.

Check that the flashing is set at a positive pitch to assure watershed.

Fasten the transition flashing to the end dams with lap fasteners spaced at 6" on center. Check that the fasteners penetrate the center of the sealant and securely engage the termination zee.



9.9 HIGH EAVE TRANSITION INSTALLATION

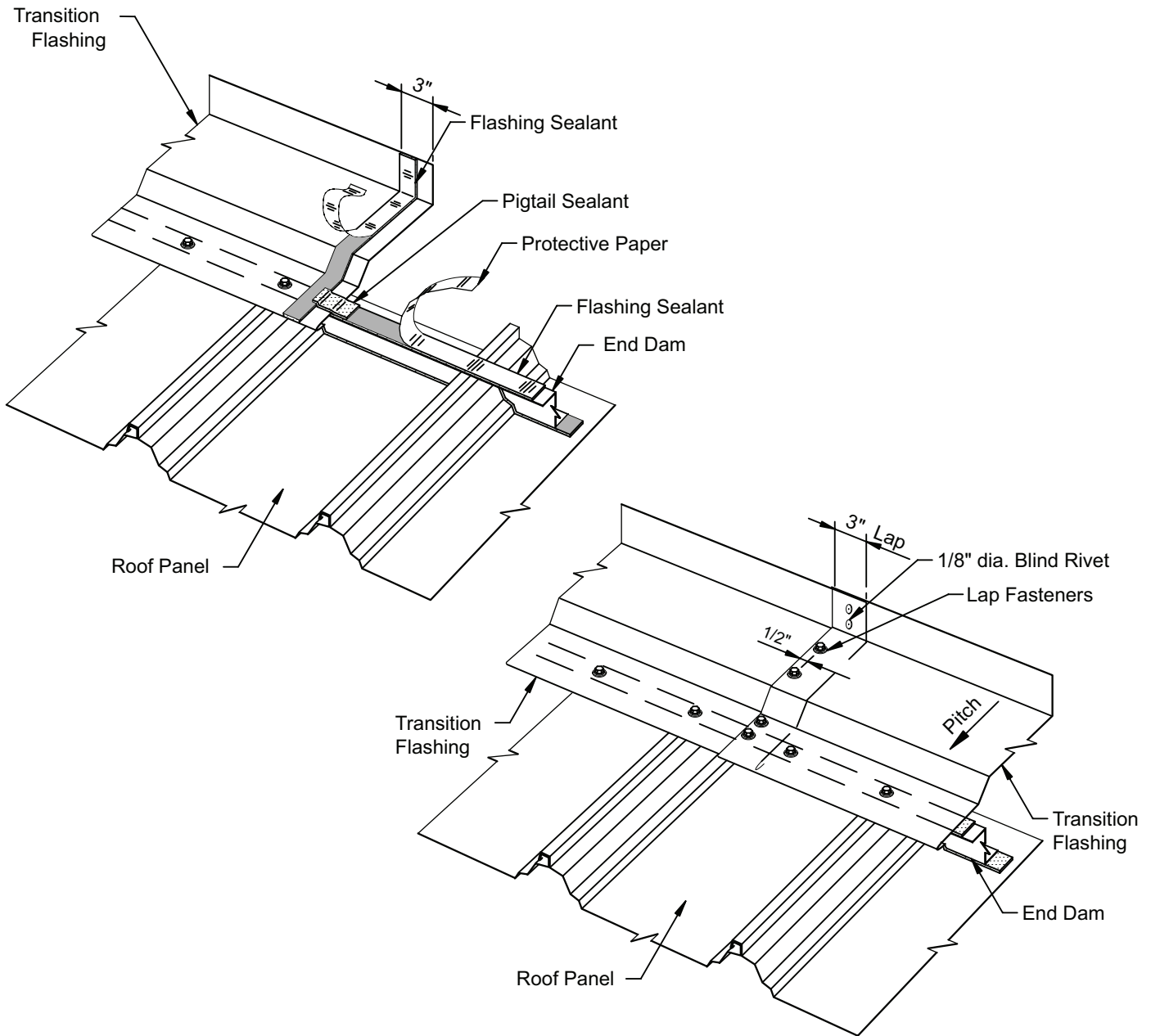

Assemble the transition flashing splices with flashing sealant and lap fasteners as shown.

Important: The splice fasteners must be installed carefully to avoid downward deflection and buckling of the flashing ends.

9.10 EAVE GUTTER INSTALLATION

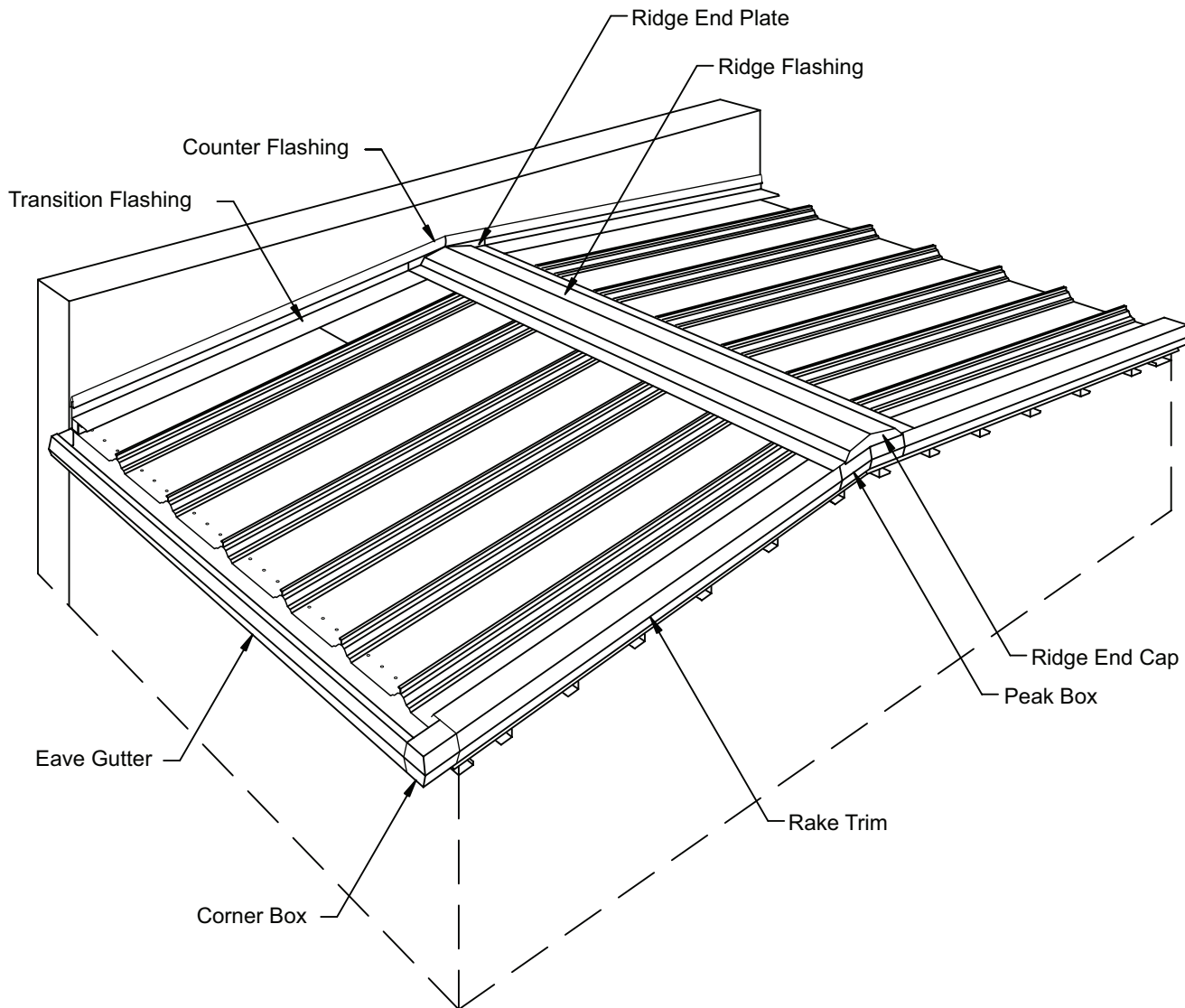

The details in this section show assembly and installation of eave gutter.

Assembly of the gutter should be accomplished with consideration given to the final appearance. The appearance of the gutter will have a critical effect on the appearance of the project.

Determine which direction the building is most often viewed from, then install gutter laps facing away from the most often viewed direction.

Proper downspouts are necessary to prevent gutter overflow and structure flooding. Refer to the erection drawings to determine the required downspout size and spacing.



9.10.1 ORIENTATION VIEW

9.10 EAVE GUTTER INSTALLATION

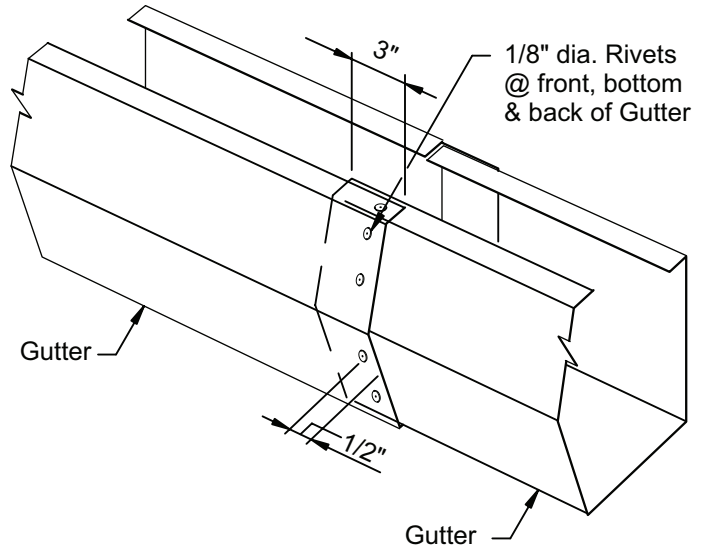
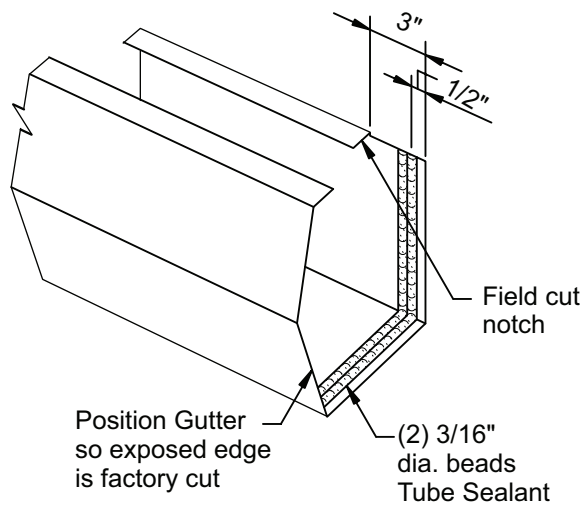

EAVE GUTTER SPLICE

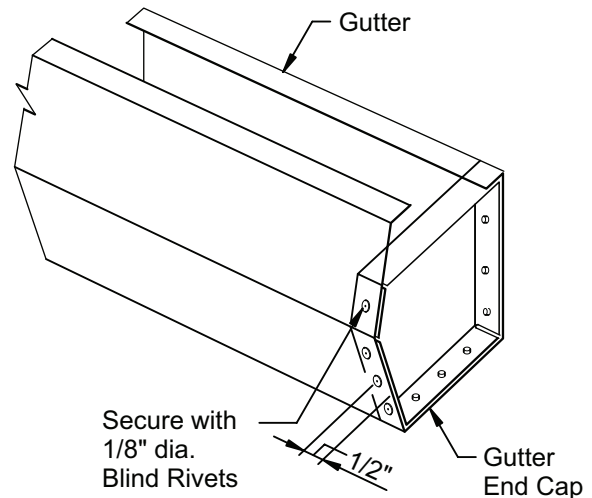
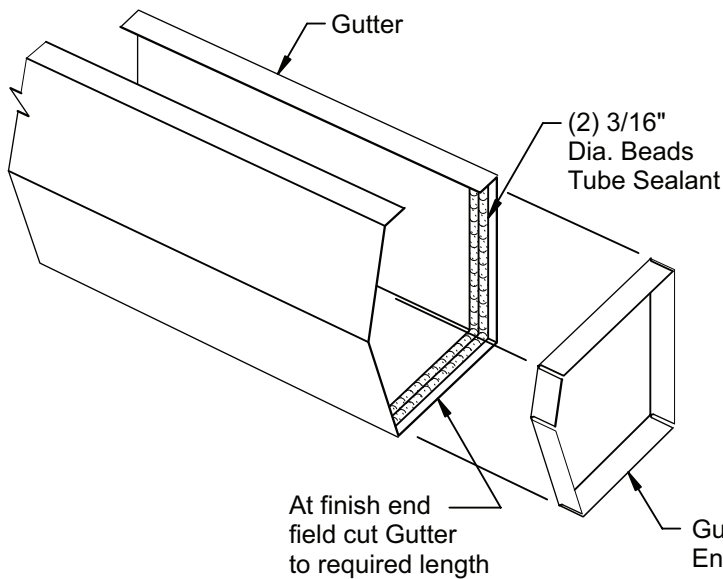

EAVE GUTTER END CAP

Layout the gutter assemblies in manageable lengths (30' to 40') before raising to the roof.

Assemble the gutter end caps and splices with tube sealant and rivets as shown on the above details.

Start and finish the gutter ends flush with the exterior face of the rake walls.

Erection Tip: Assemble lengths on the ground then with proper man power slide the length under the eave and temporary clamp to eave overhang for fastening through the factory punched holes.

9.10 EAVE GUTTER INSTALLATION

NOTE
Refer to shop drawings for
Gutter Support spacing

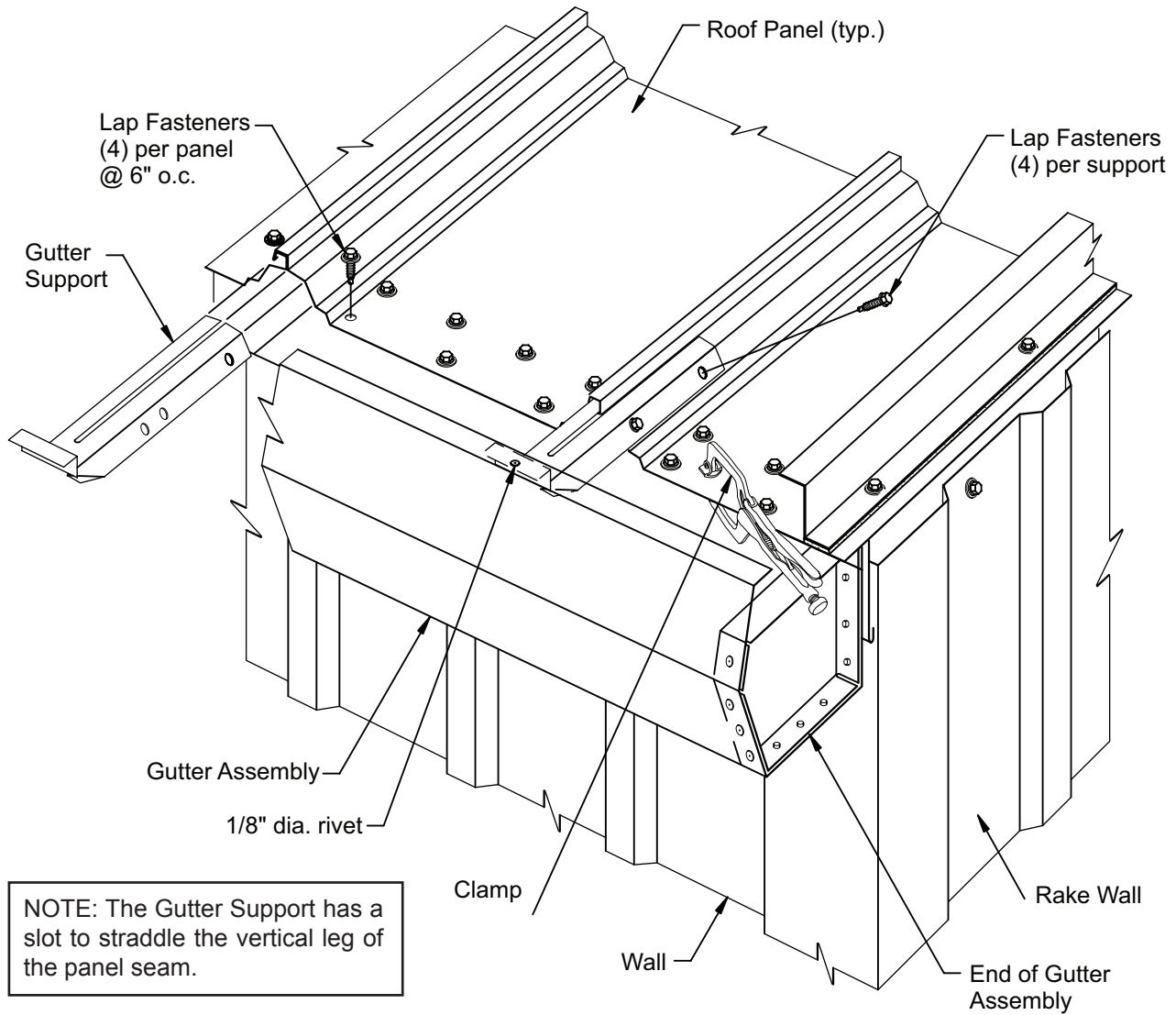

NOTE: The Gutter Support has a slot to straddle the vertical leg of the panel seam.

Lift the gutter assembly into position under the edge of the roof panels and temporarily clamp the back flange of the gutter to the roof panel.

Apply strips of flashing sealant to the inside and along the length of the gutter supports. Position the sealant over the factory punched holes in the support.

Position the back face of the gutter assembly flush against the eave trim and position its ends flush with the exterior face of the rake wall.

Install the gutter supports and fasten to the roof panel with lap fasteners. Refer to erection drawings for the required gutter support spacing.

Fasten the gutter's back flange to the underside of the roof panel with lap fasteners through pre-punched holes as shown.

Align the outer edge of the gutter straight and level. Use a string line to assure that the gutter is straight.

Check that the lap fasteners are securely engaged into the gutter's back flange.

Fasten the gutter's outer flange to the end of the gutter support with a rivet as shown.



9.10 EAVE GUTTER INSTALLATION

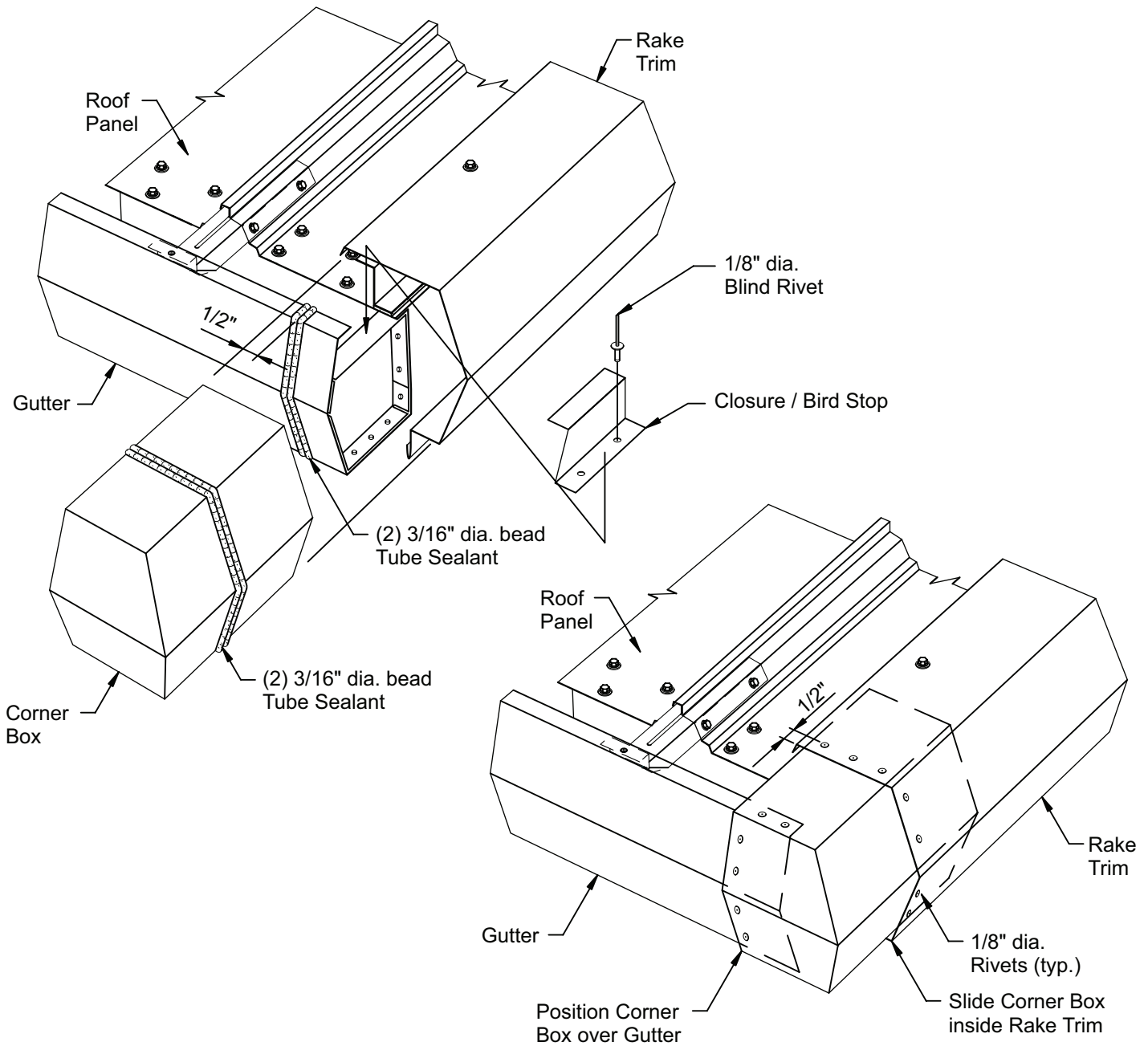

Install the corner boxes as shown.

Install bird stop on top of gutter end stop and align with termination zee or panel hem.

Position the corner box to lap over the face of the gutter and inside of the rake trim.

Carefully align the corner box so it is straight and level with the gutter and the rake trim.

Attach the corner box with tube sealant and rivets as shown.

9.11 HIP AND VALLEY INSTALLATION

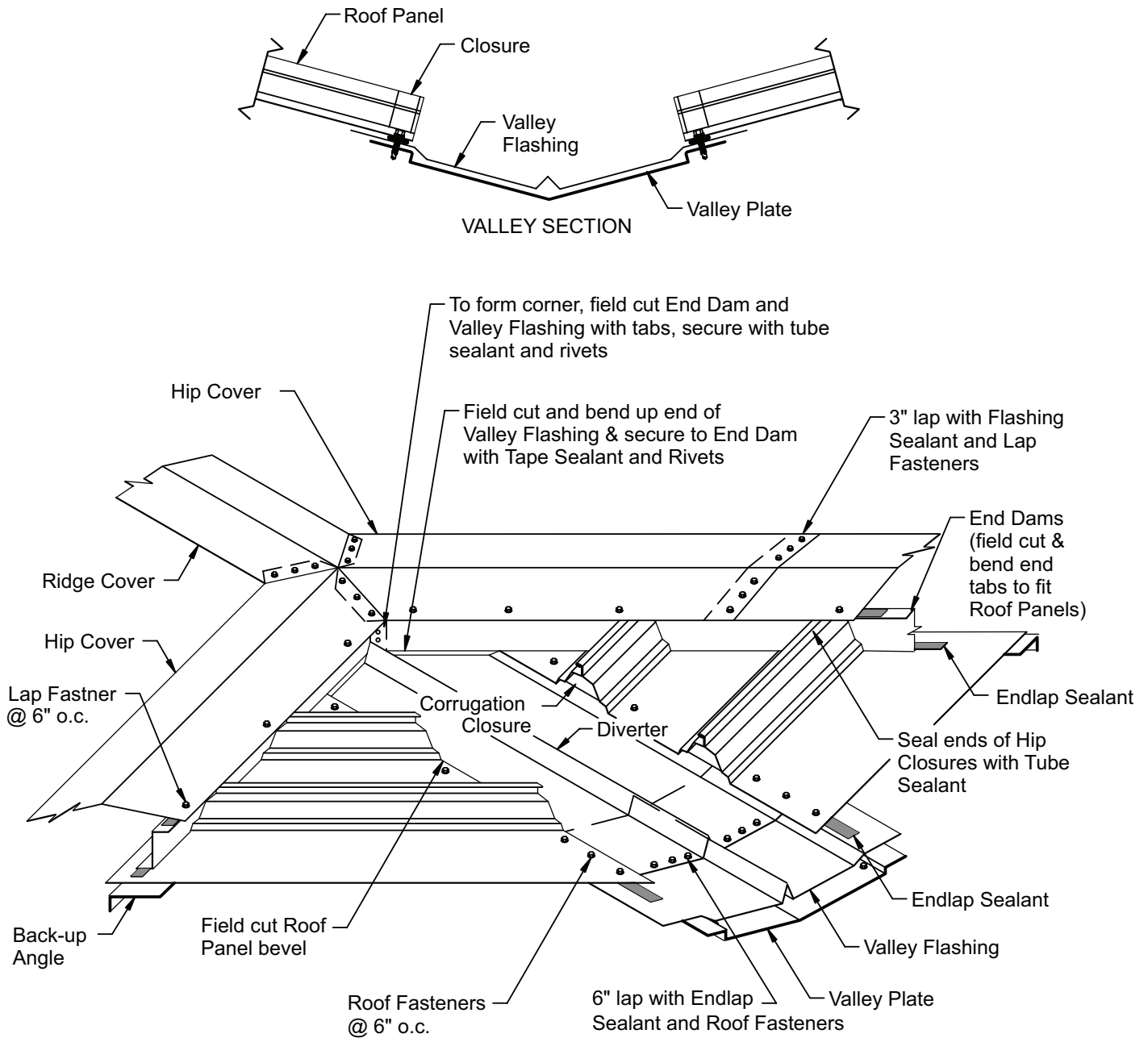

The above details show typical hip and valley details. Refer to the erection drawings for specific hip and valley details.

Valley conditions require beveled corrugation closures to accommodate the beveled roof panel ends.

Hip conditions are similar to ridge conditions, except special end dams and back-up angles are required to accommodate the beveled roof panel ends.

